

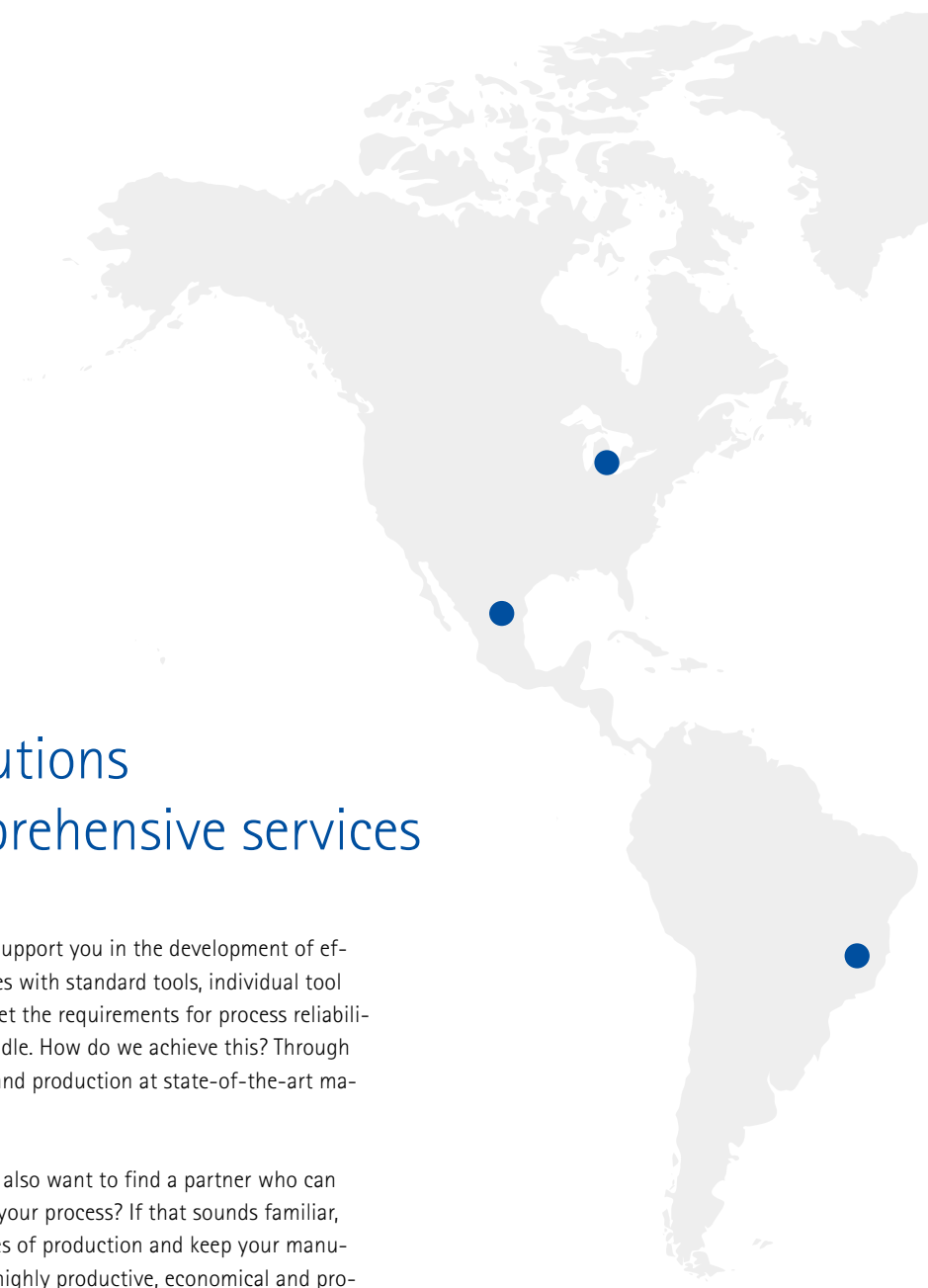

Your technology partner for cost-effective machining

MILLING



Tool and process solutions combined with comprehensive services

We see ourselves as a technology partner ready to support you in the development of efficient and resource-saving manufacturing processes with standard tools, individual tool concepts and tool detail optimisation. Our tools meet the requirements for process reliability, offer high levels of precision and are easy to handle. How do we achieve this? Through advanced development and construction methods and production at state-of-the-art manufacturing facilities.

You're looking for the perfect tool for your task but also want to find a partner who can take over and manage the entire planning stage of your process? If that sounds familiar, we're here for you. We support you during all phases of production and keep your manufacturing processes at the highest level – by being highly productive, economical and process-reliable. We also offer you complete networked solutions for all peripheral tasks related to the actual machining process.

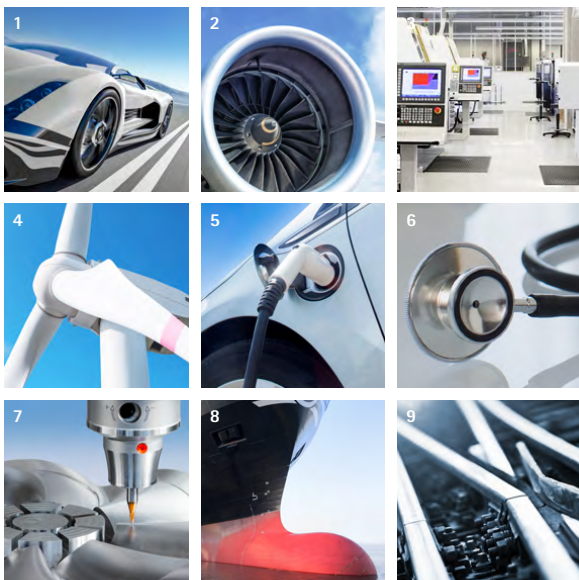

Sectors

- 1 Automotive
- 2 Aerospace
- 3 Machine engineering
- 4 Power generation
- 5 Electric mobility
- 6 Medical technology
- 7 Die & Mould sector
- 8 Shipbuilding
- 9 Rail transport



Over
5,000
 employees worldwide

No. 1
 technology leader
 for the machining
 of cubic parts



Product lines

- 1 Reaming and fine boring
- 2 Drilling from solid, boring and countersinking
- 3 Milling
- 4 Turning
- 5 Actuating
- 6 Clamping
- 7 Setting, measuring and dispensing
- 8 Services

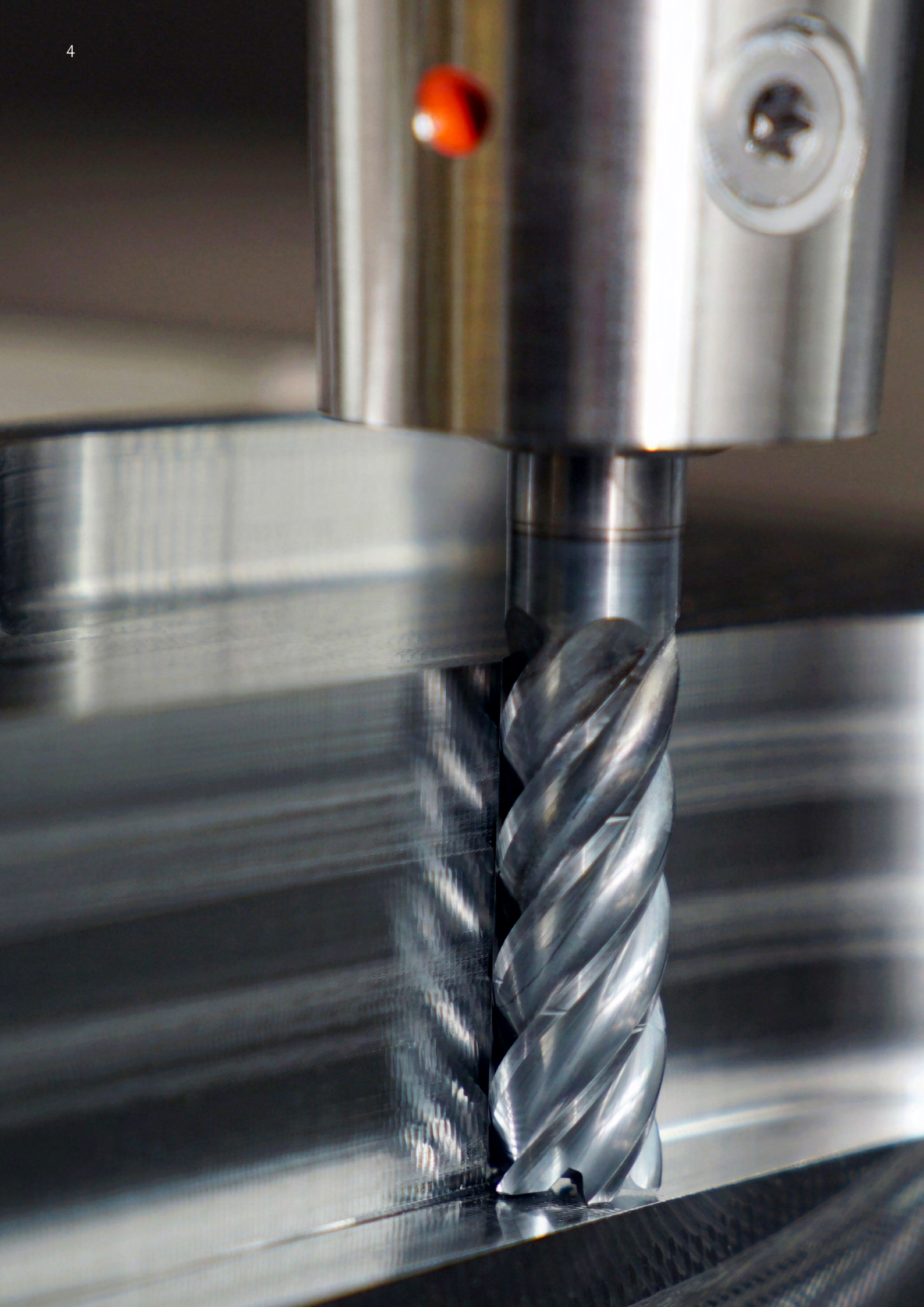

CONTENTS

01 Introduction

Competence milling	6
Overview of the range	8
Special solutions	10

02 End milling cutter with fixed cutting edges

Product overview, selection guide, product ID codes	18
Shoulder milling cutter	
Universal application	35
Roughing	107
Finishing	133
Trochoidal milling	151
High-feed milling cutters	169
Profile milling cutter	181
Chamfering, drilling and deburring milling cutters	205
CFS replaceable head holder	217

03 Milling cutters with replaceable inserts

Product overview, selection guide, product ID codes	222
Face milling cutters	249
Shoulder milling cutters	291
High-feed milling cutters	309
Copy milling cutter	333
Shell end face milling cutters	343
Helix milling cutter	357
Disc milling cutters	367
Accessories and spare parts	377

04 Technical appendix

General technical information, application instructions, handling instructions, MAPAL Maintenance Services	393
---------------------------------------------------------------------------------------------------------------------	-----

COMPETENCE MILLING

In the area of milling, the MAPAL tool experts have developed numerous machining solutions in recent years. The focus has been on tools adapted to the respective customer requirements. In addition to individual tool solutions, however, the use of high-performance standard tools plays a significant role in many applications. Therefore, an extensive standard range has been developed on the basis of custom tools.

MAPAL's many years of experience, accumulated know-how and high level of process understanding in the area of milling are reflected in the standard range. Process reliability, efficiency and the highest productivity for customers are therefore guaranteed.

Milling cutters from MAPAL only find their way to the customer after extensive research and development, design and simulation using the latest software, and production and inspection on the latest manufacturing equipment. In conjunction with the most efficient cutting materials, MAPAL therefore offers the optimal milling tool for almost all applications and workpiece materials.

For all applications

MAPAL offers the right tool for every milling operation: on the one hand, end milling cutters with fixed cutting edges, on the other hand, milling cutters with replaceable cutting edges. All types of machining – whether general such as groove milling, face milling, shoulder milling, for roughing and finishing or special such as trochoidal or helix milling – are covered with innovative tool solutions.

For all workpiece materials

Besides the type of machining, the workpiece material is the most important selection criterion for the right milling cutter. In addition to tools for machining steel, cast iron and aluminium, the MAPAL range also includes solutions for the economical and process-reliable milling of titanium, super alloys, plastics and composite materials.

Special solutions

Special machining tasks require special tools. MAPAL therefore offers milling tools in special designs, individually tailored to the customer's requirements. For example, specially designed milling cutters can be used to realise complex shapes and contours or combination tools can be used to reduce machining times and tool changes.

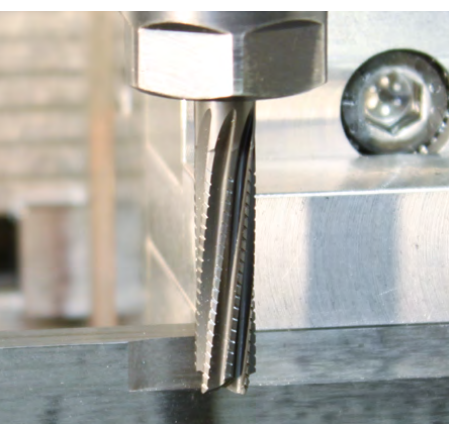



Competence milling in action – plunging at an angle of up to 45 degrees

Time-consuming ramping processes or pilot bores are often required when milling pockets. The OptiMill-Uni-HPC-Pocket has a unique face geometry with an integrated drill tip. This geometry enables the milling cutter to plunge at an angle of up to 45 degrees, helix milling and even grooving.

► [Further information on the product from page 47.](#)

High-performance coatings

The coating of the cutting edges is a decisive criterion for the tool life and optimal machining results. MAPAL offers a wide range of substrates and coatings, each matched to the machining task at hand, including the in-house state-of-the-art coating system.

The most modern manufacturing facilities

State-of-the-art 3D design and simulations form the basis for manufacturing MAPAL tools. The data is transferred via connections to the respective machining centre in the modern and extensive machine park. Monitored and controlled by experienced employees, MAPAL milling tools are created to meet the highest quality requirements.

Reconditioning to original manufacturer quality

By reconditioning solid carbide tools with original grinding and coating, almost 100% of new tool life can be achieved once again. For fast processing, MAPAL can collect and deliver tools upon request. The milling head management for PCD face milling cutters guarantees precise and reliable tools as well as 24-hour availability on site.

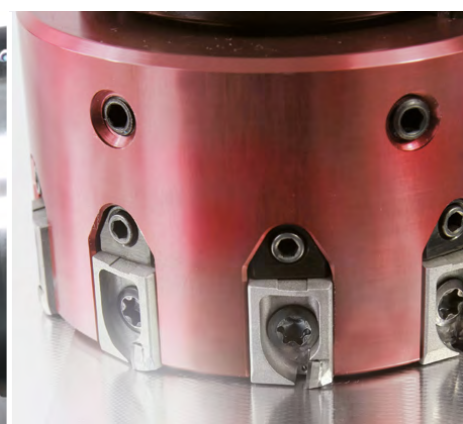
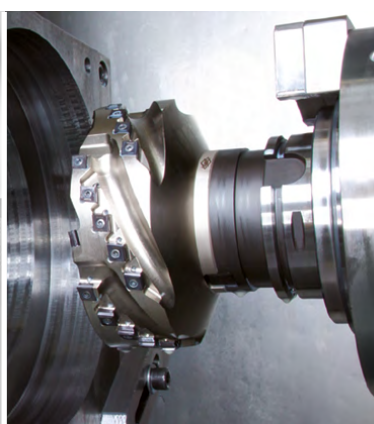
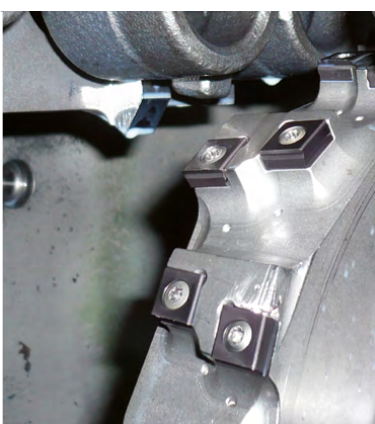

OVERVIEW OF THE RANGE

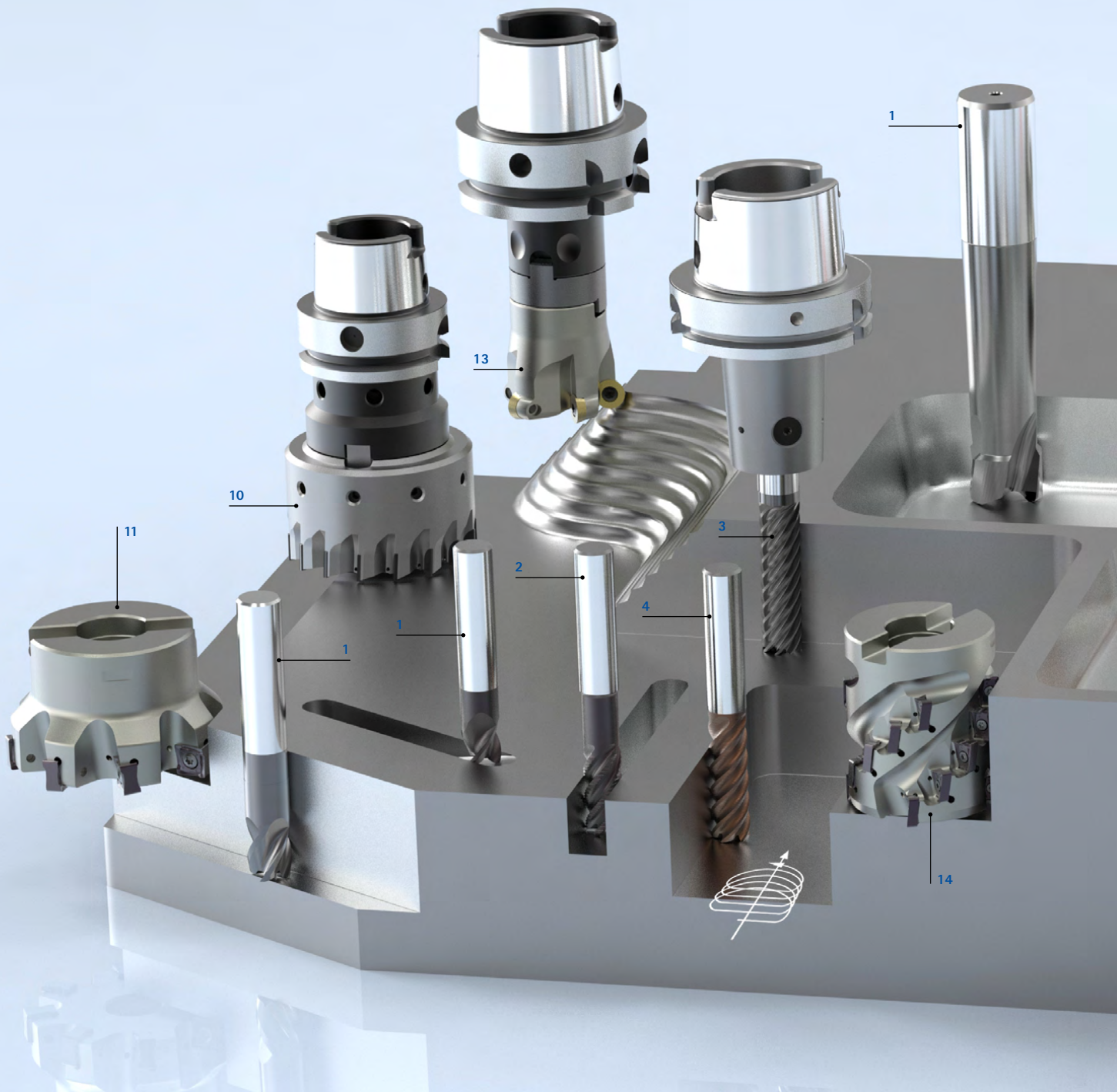

End milling cutter with fixed cutting edges

- 1 Shoulder milling cutter – universal application (from page 35)
- 2 Shoulder milling cutter – roughing (from page 107)
- 3 Shoulder milling cutter – finishing (from page 133)
- 4 Shoulder milling cutter – trochoidal milling (from page 151)

- 5 High-feed milling cutter (from page 169)
- 6 Profile milling cutter (from page 181)
- 7 Chamfering, deburring and drill milling cutter (from page 205)

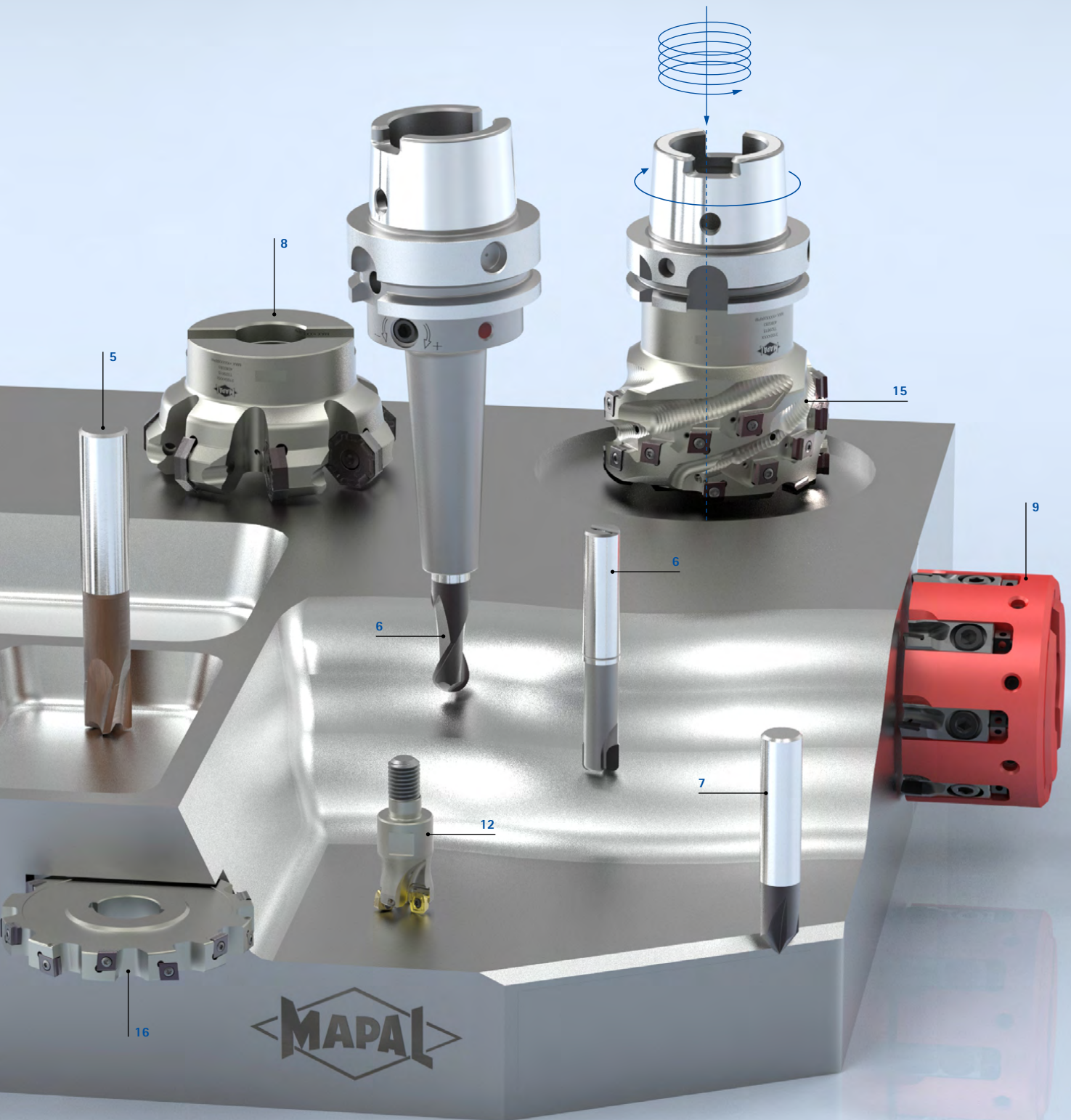

Milling cutters with replaceable inserts

- 8 Face milling cutter with indexable inserts (from page 249)
- 9 Face milling cutter with PCD milling cartridges (from page 249)
- 10 Face milling cutter with brazed PCD cutting edges (from page 249)
- 11 Shoulder milling cutter (from page 291)
- 12 High-feed milling cutter (from page 309)

- 13 Copy milling cutter (from page 333)
- 14 Shell end face milling cutter (from page 343)
- 15 Helix milling cutter (from page 357)
- 16 Disc milling cutter (from page 367)

SPECIAL SOLUTIONS

End milling cutter with fixed cutting edges

In addition to an extensive standard range of end milling cutters with fixed cutting edges, MAPAL also offers special end milling cutters that are specially tailored to the machining tasks in question. Complex geometries and contours can be realised for high-precision and flexible manufacturing options. Even unusual tool concepts for combining machining steps or combination machining can be implemented at short notice – from complex form cutters to solid carbide disc milling cutters.





Application examples for special milling cutters

- 1 PCD circular milling cutter, two cutting edges, for recesses in aluminium parts.
- 2 Solid carbide special end milling cutter, five cutting edges, special coating and radial coolant outlets in the chip flute. Application in the machining of car steering housing made of AlSi9Cu3.
- 3 Solid carbide special end milling cutter, five cutting edges, left-hand helix with special roughing profile for machining car tailgates.
- 4 Solid carbide special form cutter, four cutting edges, special unequal spacing with eroded forming step. Optimisation of the machining of a bearing carrier made of AlSi1.
- 5 Solid carbide special disc milling cutters, 16 cutting edges, close tolerance contour of the form cutting edges. Application for machining automobile hinges made of S355J2.
- 6 Solid carbide special annular groove milling cutter, four cutting edges, straight fluted – form cutter with eroded peripheral flutes. Machining the fuel supply of common rail housing.
- 7 Solid carbide special ball nose milling cutter, four cutting edges for deburring wheel carriers made of AlMgSi1.
- 8 Solid carbide special form cutter, four cutting edges, prism and radius form. Machining the combustion chamber of an aluminium cylinder head.
- 9 Replaceable head ball nose milling cutter for soft and hard machining of homokinetic joints in a drive train. PcBN-tipped tools with hollow shank taper holder are used for hard milling.

SPECIAL SOLUTIONS

Special PCD tools for face milling and circular milling

In addition to the standard series, MAPAL often develops special solutions in the field of PCD milling tools, which are designed for a specific application. The latest manufacturing technologies, such as finishing lasers, make tools possible that solve highly demanding machining tasks. In this way, tool solutions with complex cutting geometries and extreme chip and helix angles can be produced that are individually adapted to the machining task in a process-reliable and reproducible manner.

The advantages of diamonds as a cutting material can be optimally utilised, especially in milling. The extreme hardness of the diamond cutting edge in combination with a highly polished rake face ensure low forces when shearing off the chip and reduce the heat introduced into the workpiece when sliding off. These are optimal conditions for the best machining qualities in terms of dimensions, surface and shape.

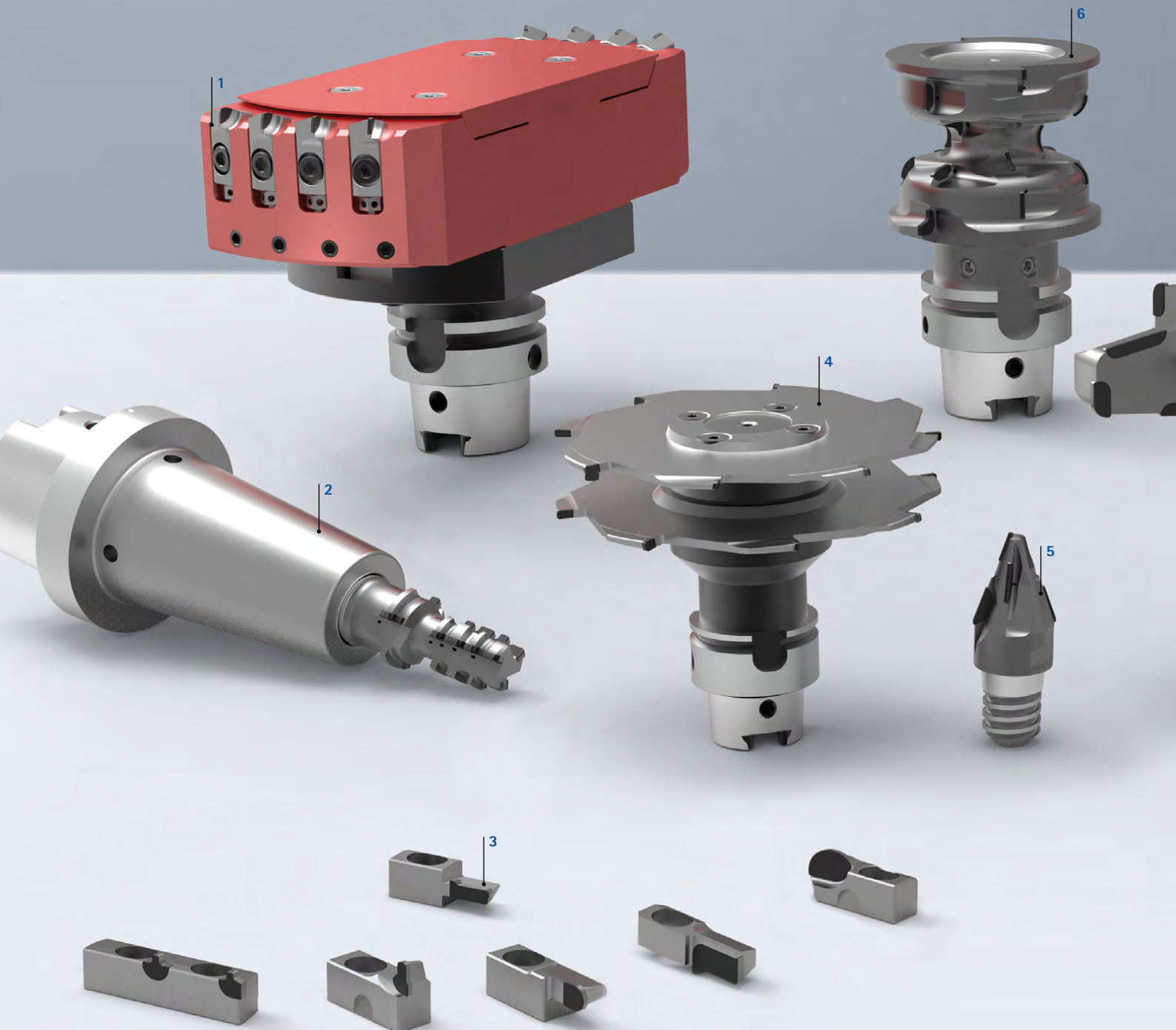



Application examples for special milling cutters

- | | |
|-----------------------------------------------------------------------------------------------------------------------------------------------------------------------------------------------------------------------------------------------------------------------------------------------------------------------------------------------------------------------------------------------------------------------------------------------------------------------------------------------------------------------------------------------------------------|-----------------------------------------------------------------------------------------------------------------------------------------------------------------------------------------------------------------------------------------------------------------------------------------------------------------------------------------------------------------------------------------------------------------------------------------------------------------------------------------------------------------------------------------|
| <p>1 Face milling cutter for cylinder head machining, combustion chamber side, different radial arrangement of PCD cutting edges for low-burr surface</p> <p>2 Circular milling cutter for machining on the connection side of a tank gun</p> <p>3 Milling inserts with special dimensions for customised machining solutions</p> <p>4 Disc milling cutter for face milling of camshaft bearing webs</p> <p>5 Chamfer milling cutter with CFS connection</p> <p>6 Circular milling cutter for machining on stabilising frame for an aircraft lifting system</p> | <p>7 Circular milling cutter for machining on stabilising frame for an aircraft lifting system</p> <p>8 Face milling cutter for brake caliper machining, back milling on the face surface of a main bore</p> <p>9 Combination milling cutter for gearbox housing machining</p> <p>10 Face milling cutter for double-sided machining on the bearing frame in a clamping setup</p> <p>11 Milling cutter for external machining on a turbocharger hose nozzle</p> <p>12 Circular milling cutter for machining on a throttle valve body</p> |
|-----------------------------------------------------------------------------------------------------------------------------------------------------------------------------------------------------------------------------------------------------------------------------------------------------------------------------------------------------------------------------------------------------------------------------------------------------------------------------------------------------------------------------------------------------------------|-----------------------------------------------------------------------------------------------------------------------------------------------------------------------------------------------------------------------------------------------------------------------------------------------------------------------------------------------------------------------------------------------------------------------------------------------------------------------------------------------------------------------------------------|

SPECIAL SOLUTIONS

Milling cutters with indexable inserts

In addition to the range of milling cutters with indexable inserts, MAPAL offers milling tools in special designs, which are individually developed for customer-specific applications. For example, complex shapes or contours are machined with innovative circular cutters that are particularly powerful due to the use of tangential technology.

Multi-stage milling tools or the combination of milling cutters with solid carbide drills can reduce tool changes. In unstable machining situations or large projection lengths, special milling cutters are designed with vibration dampers to increase machining quality and tool life.

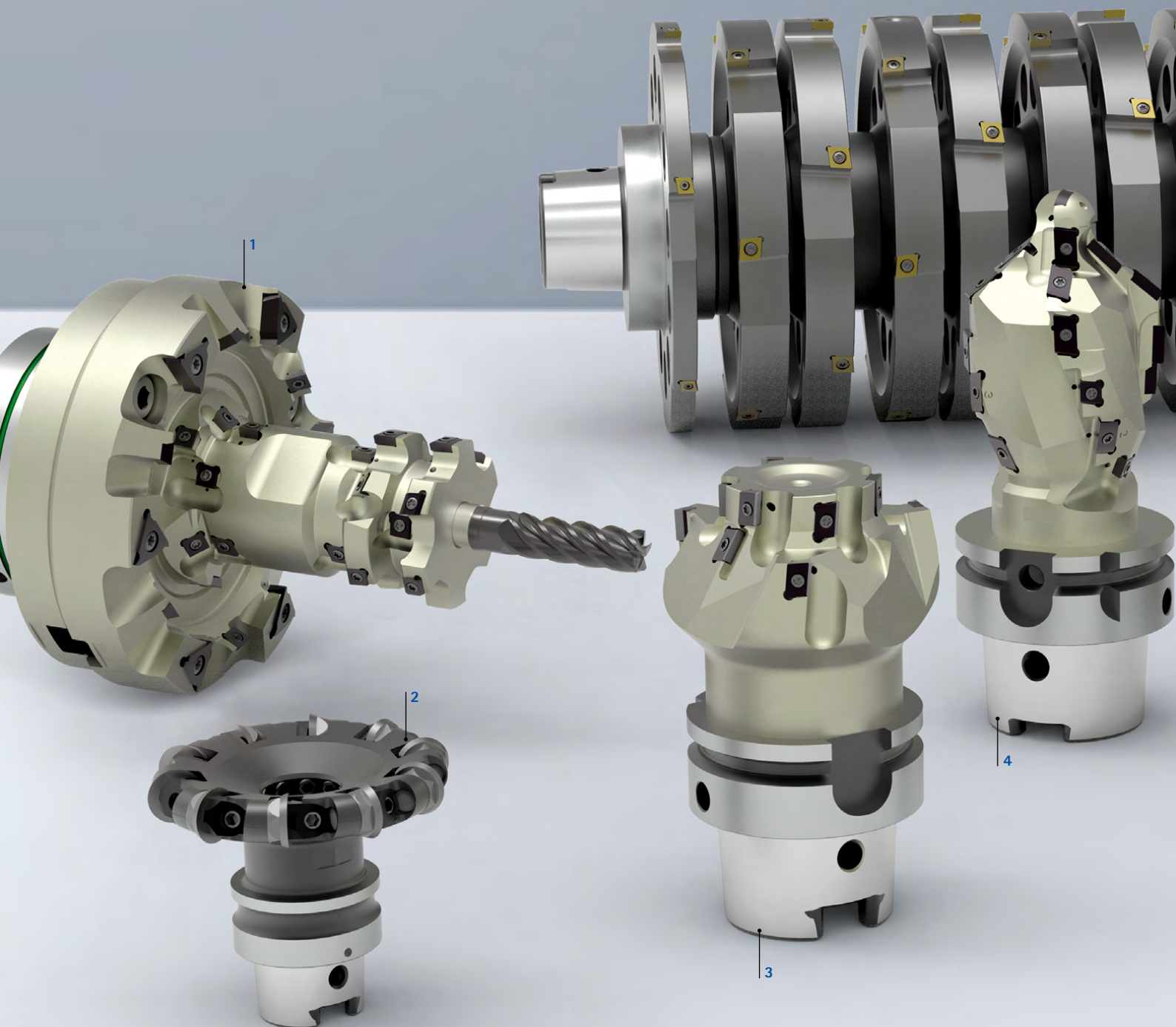

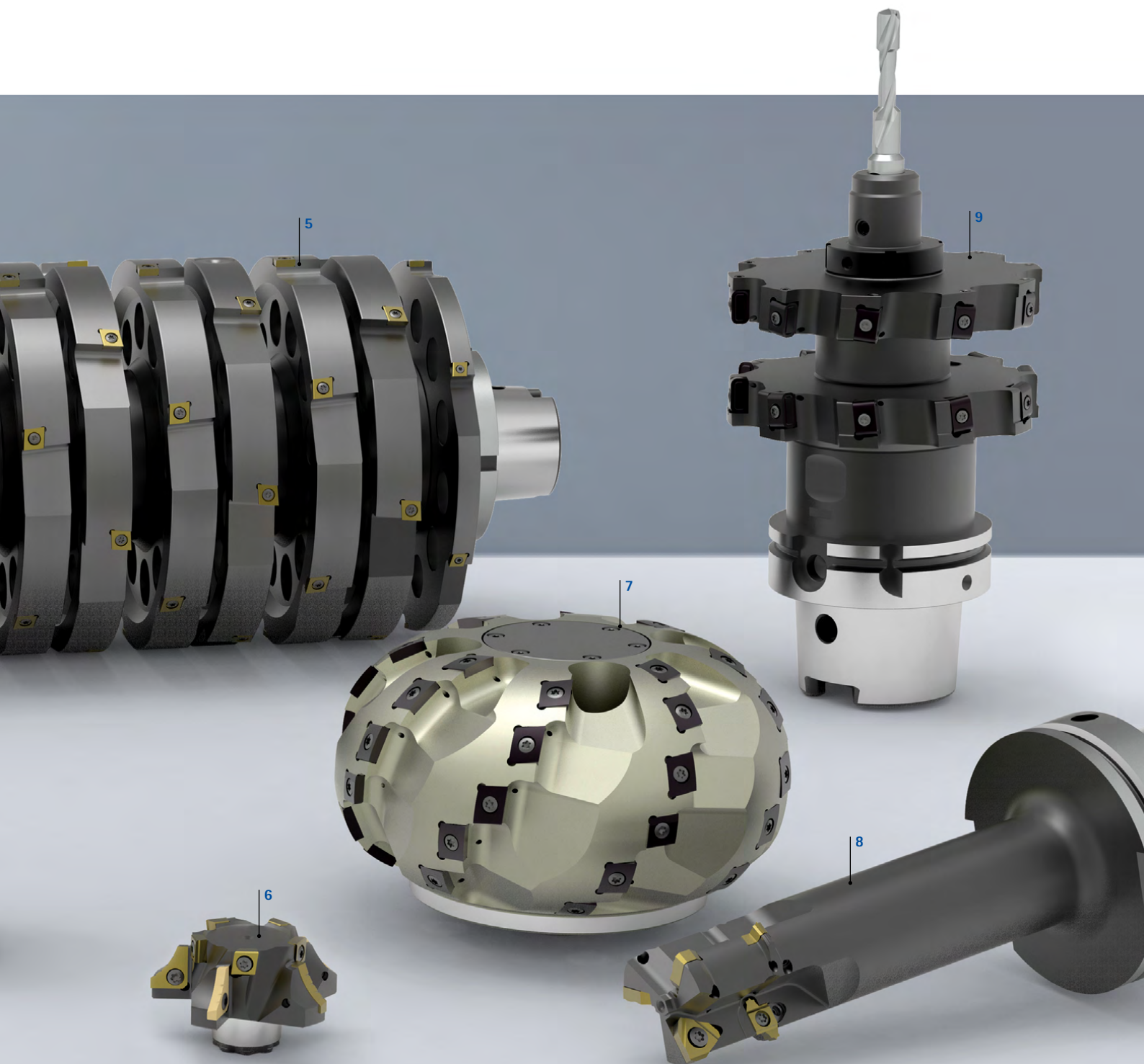

Application examples for special milling cutters

- 1 Multi-stage tangential milling cutter which combines many steps for machining planetary carriers
- 2 Contour milling cutter with PCD cutting edges for machining optical components
- 3 Multi-stage profile milling cutter for machining contours on a main brake cylinder
- 4 Circular milling cutter with tangential inserts for machining contours on a cylinder crankcase
- 5 Double-bearing gang milling cutter for machining the crankshaft bearing aisle on special machines
- 6 Modular profile milling cutter for internal machining of an oil shaft bearing bore
- 7 Form cutter for radial contours on housings for large gearboxes
- 8 Circular milling cutter for recesses on a brake housing
- 9 Combination of disc milling cutter and insertion drill for machining steering knuckles

END MILLING CUTTERS WITH FIXED CUTTING EDGES

Milling cutter for almost all applications and workpiece materials.



PRODUCT OVERVIEW

End milling cutter with fixed cutting edges

The powerful OptiMill end milling cutter range from MAPAL ensures excellent and process-reliable results for all machining tasks. Cost-effectiveness and product quality are particularly important in meeting customer requirements.

Application-based

The end milling cutter range from MAPAL includes shoulder milling cutters for universal applications, for roughing, finishing and trochoidal milling as well as milling cutters for high-feed milling, profile milling and chamfering.

Leading through flexibility

The CPMill replaceable milling cutter range also saves set-up costs. Due to the easy, safe handling, the milling heads can be directly replaced in the machine tool.

Always the right choice

Regardless of whether an economical milling cutter is required for universal machining or an expert for a complex machining task – MAPAL offers the right tool.



Basic
LINE

Basic Line:
Universal tools, broad field of application, low procurement costs

Performance
LINE

Performance Line:
High-performance tools, broad field of application, high productivity in series production

Expert
LINE

Expert Line:
Specialist tools for selected applications, maximum precision and productivity

Shoulder milling cutter

<p>Universal application</p> <p>Shoulder milling cutter for universal application. Cutting width a_e up to $1xD$.</p> <ul style="list-style-type: none"> - OptiMill-Uni-HPC-Plus for highly economical universal machining of steel, stainless steel and cast iron - OptiMill-HPC-Pocket: Face geometry with integrated drill tip. Perfect for inclined plunging up to 45°, in helix milling and grooving - OptiMill-SPM for machining structural parts made of aluminium - OptiMill-Diamond: PCD-tipped milling cutters for extremely long tool life in non-metallic workpiece materials <p>\varnothing area: 1.00 - 63.00 mm</p> <p>P M K N C H</p>	<p>Roughing</p> <p>For achieving maximum cutting volumes. Ideal for pre-machining with large stock removal. Large material removal rate ($a_e \sim 0.6xD$).</p> <ul style="list-style-type: none"> - OptiMill-Uni-HPC-Rough: Knurled profile for optimised force distribution on the cutting edges and therefore better chip formation - OptiMill-Uni-Wave: Ideal for roughing with high feed rates. Low radial forces due to newly developed roughing profile - OptiMill-SPM-Rough: High infeed depths and maximum feed rates for roughing in aluminium - ECU-Mill-Rough&Finish: Roughing-finishing milling in one machining step <p>\varnothing area: 4.00 - 25.00 mm</p> <p>P M K N</p>	<p>Finishing</p> <p>Ideal for producing the top-quality surface finishes. Fine machining with low stock removal. Low material removal rate ($a_e \leq 0.1xD$).</p> <ul style="list-style-type: none"> - OptiMill-Uni-HPC-Finish with seven cutting edges for the highest surface quality in the shortest possible time - OptiMill-Hardened-Finish for finishing components with a hardness of 45 HRC and above - OptiMill-SPM-Finish for finishing deep pockets and delicate component structures in aluminium even with large wrappings <p>\varnothing area: 4.00 - 25.00 mm</p> <p>P M K N H</p>	<p>Trochoidal milling</p> <p>Maximum material removal rate while providing an excellent surface finish at the same time. Cutting depth up to $5xD$.</p> <p>OptiMill-Tro:</p> <ul style="list-style-type: none"> - Pre-machining and fine machining with one tool - Extra long cutting area - Optimised unequal spacing and finely balanced cutting tool for protecting the machine spindle and a longer tool life - Chip breaker for optimum chip control <p>\varnothing area: 4.00 - 25.00 mm</p> <p>P M K S H</p>
<p>Page 35</p>	<p>Page 107</p>	<p>Page 133</p>	<p>Page 151</p>

















High-feed milling cutter	Ball nose and corner radius milling cutter	Chamfering, deburring, drill milling cutters
		
<p>Milling at high feed rates</p> <p>Perfect for high-feed machining with a high material removal rate, offering great process reliability. Low cutting depth ($a_p = 0.05xD$).</p> <p>OptiMill-3D-HF:</p> <ul style="list-style-type: none"> - Extremely quiet running - Hard and soft machining of steel - High feed rates with up to 1.35 mm per tooth with diameter 20.00 mm - Angled entry and pocket milling with long projection lengths <p>∅ area: 2.00 - 25.00 mm</p> <p>P M K H</p>	<p>High precision machining of 3D contours</p> <p>Contour and copy milling with high shape accuracy.</p> <ul style="list-style-type: none"> - OptiMill-3D-BN: High-precision milling cutters with high radius accuracy for hard and soft machining of steel - OptiMill-Diamond-Radius and -Torus: PCD cutting edges for long tool lives in aluminium - OptiMill-Composite-Speed-Radius for repair work on CFRP structures <p>∅ area: 1.00 - 25.00 mm</p> <p>P M K N C H</p>	<p>Chamfering, deburring and drill milling</p> <ul style="list-style-type: none"> - OptiMill-Chamfer: Cost-effective chamfering and deburring of pre-machined parts - OptiMill-DrillMill: Drill milling cutter for combination machining in one machining step, especially for sheet metal and thin-walled parts - CPD-Spot-Drill for tapping and centring - Designs with a replaceable head system for maximum flexibility and economic efficiency <p>∅ area: 3.00 - 20.00 mm</p> <p>P M K N</p>
<p>Page 169</p>	<p>Page 181</p>	<p>Page 205</p>

SELECTING A MILLING CUTTER

Step-by-step guide to selecting the right milling cutter

For example, are you looking for a shoulder milling cutter for universal use in steel with which you can also ramp?
This selection guide explains how to choose the right milling cutter step by step.

1	Type of milling cutter	Select the type of milling cutter you need.	➤		Shoulder milling cutter – universal application		Shoulder milling cutter – roughing
2	Design	Select your preferred design.	➤		Monolithic		Modular
3	Product category	Choose a product category.	➤	 Basic Line: Universal tools, broad field of application, low procurement costs			
4	Material suitability	Select your workpiece according to the MAPAL machining groups (MMG). You'll find the MMG chart on the fold-out page at the end of the catalogue.	➤		Steel		Stainless steel
5	Application	Select your preferred application.	➤		Shoulder milling		Groove milling
					Helix milling		Trochoidal milling
6	Design	Check that the geometric features meet your requirements.	➤		45° chamfer		Sharp-edged
7	Product	Select the milling cutter you need. Products of the preferred series are in stock and available at short notice, while products with configurable features can be freely configured within predefined limits.	➤	 Preferred series in stock			

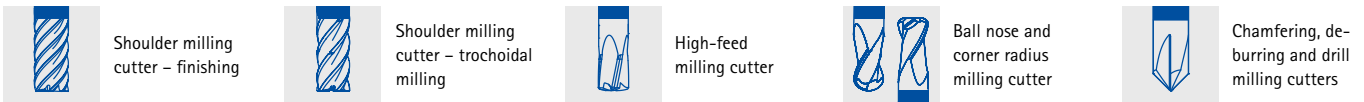

Performance Line:
High-performance tools, broad field of application, high productivity in series production

Expert Line:
Specialist tools for selected applications, maximum precision and productivity

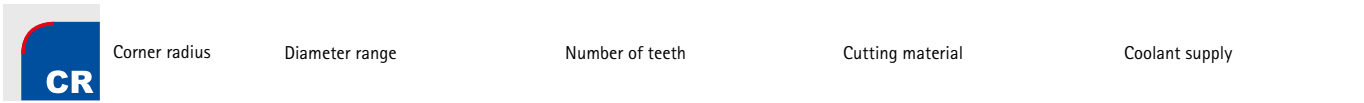
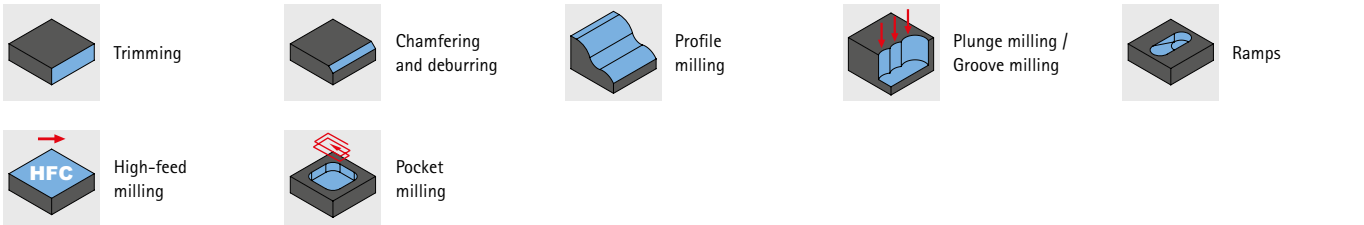
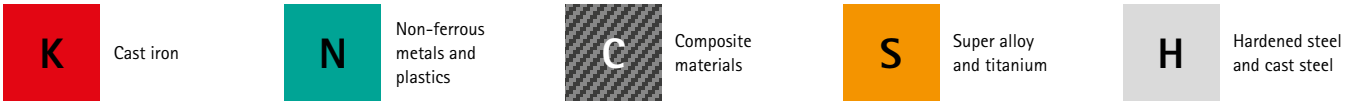

CONFIG
Product with configurable features



Shoulder milling cutter – universal application (1/2)

Design	Product category	Material suitability															Application																							
		P			M		K		N				C		S			H																						
		1-3	4	5	6	1-3	1-3	1	2	3	4	1	2	1-5	1	2	3																							
		<input type="checkbox"/>	<input type="checkbox"/>	<input type="checkbox"/>	<input type="checkbox"/>	<input type="checkbox"/>	<input type="checkbox"/>								<input type="checkbox"/>				<input checked="" type="checkbox"/>	<input type="checkbox"/>	<input type="checkbox"/>					<input type="checkbox"/>	<input type="checkbox"/>	<input type="checkbox"/>		<input type="checkbox"/>			<input checked="" type="checkbox"/>	<input type="checkbox"/>	<input type="checkbox"/>		<input type="checkbox"/>			
		<input type="checkbox"/>	<input type="checkbox"/>	<input type="checkbox"/>	<input type="checkbox"/>	<input type="checkbox"/>	<input type="checkbox"/>									<input type="checkbox"/>				<input checked="" type="checkbox"/>	<input type="checkbox"/>	<input type="checkbox"/>					<input type="checkbox"/>	<input type="checkbox"/>	<input type="checkbox"/>		<input type="checkbox"/>			<input checked="" type="checkbox"/>	<input type="checkbox"/>	<input type="checkbox"/>		<input type="checkbox"/>		
		<input type="checkbox"/>	<input type="checkbox"/>	<input type="checkbox"/>	<input type="checkbox"/>	<input type="checkbox"/>	<input type="checkbox"/>														<input checked="" type="checkbox"/>	<input type="checkbox"/>	<input type="checkbox"/>					<input type="checkbox"/>	<input type="checkbox"/>	<input type="checkbox"/>		<input type="checkbox"/>			<input checked="" type="checkbox"/>	<input type="checkbox"/>	<input type="checkbox"/>		<input type="checkbox"/>	
		<input type="checkbox"/>	<input type="checkbox"/>	<input type="checkbox"/>	<input type="checkbox"/>	<input type="checkbox"/>	<input type="checkbox"/>														<input checked="" type="checkbox"/>	<input type="checkbox"/>	<input type="checkbox"/>					<input type="checkbox"/>	<input type="checkbox"/>	<input type="checkbox"/>		<input type="checkbox"/>			<input checked="" type="checkbox"/>	<input type="checkbox"/>	<input type="checkbox"/>		<input type="checkbox"/>	
		<input type="checkbox"/>	<input type="checkbox"/>	<input type="checkbox"/>	<input type="checkbox"/>	<input type="checkbox"/>	<input type="checkbox"/>														<input checked="" type="checkbox"/>	<input type="checkbox"/>	<input type="checkbox"/>					<input type="checkbox"/>	<input type="checkbox"/>	<input type="checkbox"/>		<input type="checkbox"/>			<input checked="" type="checkbox"/>	<input type="checkbox"/>	<input type="checkbox"/>		<input type="checkbox"/>	
		<input type="checkbox"/>	<input type="checkbox"/>	<input type="checkbox"/>	<input type="checkbox"/>	<input type="checkbox"/>	<input type="checkbox"/>														<input checked="" type="checkbox"/>	<input type="checkbox"/>	<input type="checkbox"/>					<input type="checkbox"/>	<input type="checkbox"/>	<input type="checkbox"/>		<input type="checkbox"/>			<input checked="" type="checkbox"/>	<input type="checkbox"/>	<input type="checkbox"/>		<input type="checkbox"/>	
		<input type="checkbox"/>	<input type="checkbox"/>	<input type="checkbox"/>	<input type="checkbox"/>	<input type="checkbox"/>	<input type="checkbox"/>														<input checked="" type="checkbox"/>	<input type="checkbox"/>	<input type="checkbox"/>					<input type="checkbox"/>	<input type="checkbox"/>	<input type="checkbox"/>		<input type="checkbox"/>			<input checked="" type="checkbox"/>	<input type="checkbox"/>	<input type="checkbox"/>		<input type="checkbox"/>	
		<input type="checkbox"/>	<input type="checkbox"/>	<input type="checkbox"/>	<input type="checkbox"/>	<input type="checkbox"/>	<input type="checkbox"/>														<input checked="" type="checkbox"/>	<input type="checkbox"/>	<input type="checkbox"/>					<input type="checkbox"/>	<input type="checkbox"/>	<input type="checkbox"/>		<input type="checkbox"/>			<input checked="" type="checkbox"/>	<input type="checkbox"/>	<input type="checkbox"/>		<input type="checkbox"/>	
		<input type="checkbox"/>	<input type="checkbox"/>	<input type="checkbox"/>	<input type="checkbox"/>	<input type="checkbox"/>	<input type="checkbox"/>														<input checked="" type="checkbox"/>	<input type="checkbox"/>	<input type="checkbox"/>					<input type="checkbox"/>	<input type="checkbox"/>	<input type="checkbox"/>		<input type="checkbox"/>			<input checked="" type="checkbox"/>	<input type="checkbox"/>	<input type="checkbox"/>		<input type="checkbox"/>	
		<input type="checkbox"/>	<input type="checkbox"/>	<input type="checkbox"/>	<input type="checkbox"/>	<input type="checkbox"/>	<input type="checkbox"/>														<input checked="" type="checkbox"/>	<input type="checkbox"/>	<input type="checkbox"/>					<input type="checkbox"/>	<input type="checkbox"/>	<input type="checkbox"/>		<input type="checkbox"/>			<input checked="" type="checkbox"/>	<input type="checkbox"/>	<input type="checkbox"/>		<input type="checkbox"/>	
		<input type="checkbox"/>	<input type="checkbox"/>	<input type="checkbox"/>	<input type="checkbox"/>	<input type="checkbox"/>	<input type="checkbox"/>														<input checked="" type="checkbox"/>	<input type="checkbox"/>	<input type="checkbox"/>					<input type="checkbox"/>	<input type="checkbox"/>	<input type="checkbox"/>		<input type="checkbox"/>			<input checked="" type="checkbox"/>	<input type="checkbox"/>	<input type="checkbox"/>		<input type="checkbox"/>	
		<input type="checkbox"/>	<input type="checkbox"/>	<input type="checkbox"/>	<input type="checkbox"/>	<input type="checkbox"/>	<input type="checkbox"/>														<input checked="" type="checkbox"/>	<input type="checkbox"/>	<input type="checkbox"/>					<input type="checkbox"/>	<input type="checkbox"/>	<input type="checkbox"/>		<input type="checkbox"/>			<input checked="" type="checkbox"/>	<input type="checkbox"/>	<input type="checkbox"/>		<input type="checkbox"/>	
		<input type="checkbox"/>	<input type="checkbox"/>	<input type="checkbox"/>	<input type="checkbox"/>	<input type="checkbox"/>	<input type="checkbox"/>														<input checked="" type="checkbox"/>	<input type="checkbox"/>	<input type="checkbox"/>					<input type="checkbox"/>	<input type="checkbox"/>	<input type="checkbox"/>		<input type="checkbox"/>			<input checked="" type="checkbox"/>	<input type="checkbox"/>	<input type="checkbox"/>		<input type="checkbox"/>	
		<input type="checkbox"/>	<input type="checkbox"/>	<input type="checkbox"/>	<input type="checkbox"/>	<input type="checkbox"/>	<input type="checkbox"/>														<input checked="" type="checkbox"/>	<input type="checkbox"/>	<input type="checkbox"/>					<input type="checkbox"/>	<input type="checkbox"/>	<input type="checkbox"/>		<input type="checkbox"/>			<input checked="" type="checkbox"/>	<input type="checkbox"/>	<input type="checkbox"/>		<input type="checkbox"/>	
		<input type="checkbox"/>	<input type="checkbox"/>	<input type="checkbox"/>	<input type="checkbox"/>	<input type="checkbox"/>	<input type="checkbox"/>														<input checked="" type="checkbox"/>	<input type="checkbox"/>	<input type="checkbox"/>					<input type="checkbox"/>	<input type="checkbox"/>	<input type="checkbox"/>		<input type="checkbox"/>			<input checked="" type="checkbox"/>	<input type="checkbox"/>	<input type="checkbox"/>		<input type="checkbox"/>	
		<input type="checkbox"/>	<input type="checkbox"/>	<input type="checkbox"/>	<input type="checkbox"/>	<input type="checkbox"/>	<input type="checkbox"/>														<input checked="" type="checkbox"/>	<input type="checkbox"/>	<input type="checkbox"/>					<input type="checkbox"/>	<input type="checkbox"/>	<input type="checkbox"/>		<input type="checkbox"/>			<input checked="" type="checkbox"/>	<input type="checkbox"/>	<input type="checkbox"/>		<input type="checkbox"/>	
		<input type="checkbox"/>	<input type="checkbox"/>	<input type="checkbox"/>	<input type="checkbox"/>	<input type="checkbox"/>	<input type="checkbox"/>														<input checked="" type="checkbox"/>	<input type="checkbox"/>	<input type="checkbox"/>					<input type="checkbox"/>	<input type="checkbox"/>	<input type="checkbox"/>		<input type="checkbox"/>			<input checked="" type="checkbox"/>	<input type="checkbox"/>	<input type="checkbox"/>		<input type="checkbox"/>	
		<input type="checkbox"/>	<input type="checkbox"/>	<input type="checkbox"/>	<input type="checkbox"/>	<input type="checkbox"/>	<input type="checkbox"/>														<input checked="" type="checkbox"/>	<input type="checkbox"/>	<input type="checkbox"/>					<input type="checkbox"/>	<input type="checkbox"/>	<input type="checkbox"/>		<input type="checkbox"/>			<input checked="" type="checkbox"/>	<input type="checkbox"/>	<input type="checkbox"/>		<input type="checkbox"/>	
		<input type="checkbox"/>	<input type="checkbox"/>	<input type="checkbox"/>	<input type="checkbox"/>	<input type="checkbox"/>	<input type="checkbox"/>														<input checked="" type="checkbox"/>	<input type="checkbox"/>	<input type="checkbox"/>					<input type="checkbox"/>	<input type="checkbox"/>	<input type="checkbox"/>		<input type="checkbox"/>			<input checked="" type="checkbox"/>	<input type="checkbox"/>	<input type="checkbox"/>		<input type="checkbox"/>	
		<input type="checkbox"/>	<input type="checkbox"/>	<input type="checkbox"/>	<input type="checkbox"/>	<input type="checkbox"/>	<input type="checkbox"/>														<input checked="" type="checkbox"/>	<input type="checkbox"/>	<input type="checkbox"/>					<input type="checkbox"/>	<input type="checkbox"/>	<input type="checkbox"/>		<input type="checkbox"/>			<input checked="" type="checkbox"/>	<input type="checkbox"/>	<input type="checkbox"/>		<input type="checkbox"/>	
		<input type="checkbox"/>	<input type="checkbox"/>	<input type="checkbox"/>	<input type="checkbox"/>	<input type="checkbox"/>	<input type="checkbox"/>														<input checked="" type="checkbox"/>	<input type="checkbox"/>	<input type="checkbox"/>					<input type="checkbox"/>	<input type="checkbox"/>	<input type="checkbox"/>		<input type="checkbox"/>			<input checked="" type="checkbox"/>	<input type="checkbox"/>	<input type="checkbox"/>		<input type="checkbox"/>	
		<input type="checkbox"/>	<input type="checkbox"/>	<input type="checkbox"/>	<input type="checkbox"/>	<input type="checkbox"/>	<input type="checkbox"/>														<input checked="" type="checkbox"/>	<input type="checkbox"/>	<input type="checkbox"/>					<input type="checkbox"/>	<input type="checkbox"/>	<input type="checkbox"/>		<input type="checkbox"/>			<input checked="" type="checkbox"/>	<input type="checkbox"/>	<input type="checkbox"/>		<input type="checkbox"/>	
		<input type="checkbox"/>	<input type="checkbox"/>	<input type="checkbox"/>	<input type="checkbox"/>	<input type="checkbox"/>	<input type="checkbox"/>														<input checked="" type="checkbox"/>	<input type="checkbox"/>	<input type="checkbox"/>					<input type="checkbox"/>	<input type="checkbox"/>	<input type="checkbox"/>		<input type="checkbox"/>			<input checked="" type="checkbox"/>	<input type="checkbox"/>	<input type="checkbox"/>		<input type="checkbox"/>	
		<input type="checkbox"/>	<input type="checkbox"/>	<input type="checkbox"/>	<input type="checkbox"/>	<input type="checkbox"/>	<input type="checkbox"/>														<input checked="" type="checkbox"/>	<input type="checkbox"/>	<input type="checkbox"/>					<input type="checkbox"/>	<input type="checkbox"/>	<input type="checkbox"/>		<input type="checkbox"/>			<input checked="" type="checkbox"/>	<input type="checkbox"/>	<input type="checkbox"/>		<input type="checkbox"/>	

★ 1. choice
 ■ highly suitable
 ■ suitable in some situations



Edge design			Design				Product			
45°	90°	CR	ø [mm]	z	Mat.		Product name	Specification		Page
✓		✓	2,5-25	4	HP		OptiMill-Uni-HPC-Plus	SCM720,740,760,770		36
✓			1-20	2	HP		OptiMill-Uni-HPC-Plus	SCM772		43
✓	✓		1-20	3	HP		OptiMill-Uni-HPC-Slot	SCM250		45
		✓	3,8-20	3	HP		OptiMill-Uni-HPC-Pocket	SCM800,810,840		47
✓			6-25	5	HP		OptiMill-Uni-HPC-Silent	SCM570		51
		✓	4-20	4	HP		OptiMill-Hardened	SCM102,103		54
✓			3-20	4	HP		OptiMill-Inox-HPC	SCM108		56
✓			3-20	3	HU		OptiMill-Alu-HPC	SCM270		57
		✓	5-20	3	HP		OptiMill-Alu-HPC-Pocket	SCM850		58
		✓	5-20	4	HP		OptiMill-Alu-HPC-Pocket	SCM854		59
✓			4-5	1	PU		OptiMill-Diamond-Typ 50	SHM500		63
✓			3-12	2	PU	✓	OptiMill-Diamond-Typ 51	SHM511,611,711		64
		✓	6-20	2-3	PU	✓	OptiMill-Diamond-Typ 53	SHM531		65
✓			16-63	3-4	PU	✓	OptiMill-Diamond-Typ 57	SHM571		66
✓			6-20	4	HC		OptiMill-Thermoplastic-FR	SCM610		76
✓			4-20	8	HU		OptiMill-Composite-Speed-Plus	SCM982, 992		70
	✓		1-3	MT	HC		OptiMill-Composite-Micro	SCM560		74
	✓		4-20	2	HU		OptiMill-Composite-TwinCut	SCM490		75
		✓	12-32	3	HU	✓	OptiMill-SPM	SCM681,691		60
		✓	6-50	3	PU	✓	OptiMill-Diamond-SPM	SHM101,110,111,121		61
✓			4-20	8	HC		OptiMill-Composite-Speed-Plus	SCM980, 990		72
✓			3-20	4	HP		ECU-Mill-Uni-LV	SCM780,790		52
	✓	✓	2-10	1	HU		OptiMill-Mono-Alu	SCM280		68
	✓		2-12	1	HU		OptiMill-Mono-Plastic	SCM330		77

Additional shoulder milling cutters for universal application on the next page.

Step 1:
Type of milling cutter



Step 2:
Design



Step 3:
Product category



Step 4:
Material suitability



Step 5:
Application

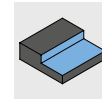

Step 6:
Design



Edge design		Design				Product				
45°	90°	CR	ø [mm]	z	Mat.		Product name	Specification		Page
✓			8-20	4	HP		CPMill-Uni-HPC	CPM100		44
✓			8-25	3	HP		CPMill-Uni-HPC-Slot	CPM110		46

Edge design		Design				Product				
45°	90°	CR	ø [mm]	z	Mat.		Product name	Specification		Page
✓			4-25	3-5	HP		OptiMill-Uni-HPC-Rough	SCM700, 710		108
✓			4-25	5	HP	✓	OptiMill-Uni-Wave	SCM880,881, 890,900,910		110
		✓	12-25	3	HU	✓	OptiMill-SPM-Rough	SCM951,961		118
✓	✓		6-20	3-4	HP		ECU-Mill-Uni-Rough&Finish	SCM220		120
✓			8-25	4-6	HP		CPMill-Uni-Rough&Finish	CPM140		121

Shoulder milling cutter – finishing

Design	Product category	Material suitability												Application															
		P						M	K	N				C		S	H			1	2	3	1	2	3	4	5	6	
		1-3	4	5	6	1-3	1-3	1	2	3	4	1	2	1-5	1	2	3	1	2	3	4	5	6	7	8	9	10	11	12
	Performance LINE	■	■	■	■	■	■							■	□										■				
	Performance LINE	■	■	■	■	■	■																						
	Performance LINE	■	■	■	■	■	■									□													

Shoulder milling cutter – trochoidal milling

Design	Product category	Material suitability												Application															
		P						M	K	N				C		S	H			1	2	3	1	2	3	4	5	6	
		1-3	4	5	6	1-3	1-3	1	2	3	4	1	2	1-5	1	2	3	1	2	3	4	5	6	7	8	9	10	11	12
	Expert LINE	■	■	■	■	■	■																	■				★	
	Expert LINE	■	■	■	■	■	■																				★		■
	Expert LINE	■	■	■	■	■	■																				★		■
	Expert LINE	■	■	■	■	■	■																				★		■
	Expert LINE	■	■	■	■	■	■								■												★		■
	Expert LINE	■	■	■	■	■	■							■													★		■
	Expert LINE	■	■	■	■	■	■								■												★		■

High-feed milling cutter

Design	Product category	Material suitability												Application															
		P						M	K	N				C		S	H			1	2	3	1	2	3	4	5	6	
		1-3	4	5	6	1-3	1-3	1	2	3	4	1	2	1-5	1	2	3	1	2	3	4	5	6	7	8	9	10	11	12
	Performance LINE	■	■	■	■	■	■									□	□											★	
	Performance LINE	■	■	■	■	■	■									■	■											★	
	Performance LINE	■	■	■	■	■	■																				★		

★ 1. choice ■ highly suitable □ suitable in some situations

Step 1:
Type of milling cutter



Step 2:
Design



Step 3:
Product category



Step 4:
Material suitability



Step 5:
Application

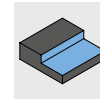

Step 6:
Design



Edge design			Design				Product			
45°	90°	CR	∅ [mm]	z	Mat.		Product name	Specification		Page
✓	✓		4-25	7	HP		OptiMill-Uni-HPC-Finish	SCM830		134
	✓		6-20	6	HP		OptiMill-Uni-HPC-Finish	SCM370		138
	✓	✓	4-25	6	HP		OptiMill-Hardened-Finish	SCM104,124		140
		✓	12-25	4	HU		OptiMill-SPM-Finish	SCM970		145
	✓		8-25	6	HP		CPMill-Uni-HPC-Finish	CPM130		139

Edge design			Design				Product			
45°	90°	CR	∅ [mm]	z	Mat.		Product name	Specification		Page
✓			4-20	5	HP		OptiMill-Tro-Uni	SCM580, 940		152
✓			4-25	5	HP		OptiMill-Tro-PM	SCM590		155
✓			4-25	7	HP		OptiMill-Tro-PM	SCM820, 930		156
		✓	6-25	5	HP		OptiMill-Tro-Titan	SCM630		162
		✓	6-25	5	HP		OptiMill-Tro-S	SCM600		161
		✓	6-25	5	HP		OptiMill-Tro-H	SCM920		160

Edge design			Design				Product			
45°	90°	CR	∅ [mm]	z	Mat.		Product name	Specification		Page
			3-16	4	HP		OptiMill-3D-HF	MHF101		170
			2-16	4	HP		OptiMill-3D-HF-Hardened	MHF102		171
			8-25	6		✓	CPMill-Uni-FeedPlus	CPM171		172



Ball nose and corner radius milling cutter

Design	Product class	Material suitability														Application																							
		P						M	K	N				C		S	H			Application icons																			
		1-3	4	5	6	1-3	1-3	1	2	3	4	1	2	1-5	1	2	3																						
 Performance LINE		■	■	■	■	■	■									■	■	■	■	■		★		■	■														
																		■	■	■		★		■	■														
														■	■	■	■	■					★																
														■	■	■	■	■					★																
														■	■	■	■	■					★			■	■												
 Basic LINE		■	■	■	■	■	■											■	■	■		■		■	■														
		■	■	■	■	■	■												■	■	■		■		■	■													



Chamfering, deburring and drill milling cutters

Design	Product class	Material suitability														Application																					
		P						M	K	N				C		S	H			Application icons																	
		1-3	4	5	6	1-3	1-3	1	2	3	4	1	2	1-5	1	2	3																				
 Basic LINE		■	■	■	■	■	■															★															
		■	■	■	■	■	■																■		■												
 Basic LINE		■	■	■	■	■	■															★															
		■	■	■	■	■	■																■														

Step 1:
Type of milling cutter



Step 2:
Design



Step 3:
Product category



Step 4:
Material suitability



Step 5:
Application

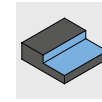

Step 6:
Design



Edge design			Design				Product			
45°	90°	CR	ø [mm]	z	Mat.		Product name	Specification		Page
			1-12	2	HP		OptiMill-3D-BN	MBN101		182
			3-12	2	HP		OptiMill-3D-BN-Hardened	MBN107		183
			4-20	8	HC		OptiMill-Composite-Speed-Radius	SCM870		188
			3-16	2	PU	✓	OptiMill-Diamond-Radius	SHM521		186
		✓	3-12	2	PU	✓	OptiMill-Diamond-Torus	SHM551		187
			8-25	4	HP		CPMill-Uni-Radius	CPM150		184
		✓	8-25	4	HP		CPMill-Uni-Torus	CPM160		185

Edge design			Design				Product			
45°	90°	CR	ø [mm]	z	Mat.		Product name	Specification		Page
			4-20	4	HP		OptiMill-Chamfer	SCM340		206
			3-16	2	HU		OptiMill-DrillMill	SCM350		209
			8-20	4/6	HP		CPMill-Chamfer	CPM180		207
	✓		10-20	3+3	HP		CPMill-Chamfer-Twin	CPM190		208

Product ID codes

Solid carbide and PCD end milling cutter

S C M - **9 4 0** - **1 2 0 0** - **A** - **Z 0 3**

Type of milling cutter

CPM	Replaceable milling cutter Complete performance milling
SCM	Solid carbide milling cutter Solid carbide milling
SHM	Milling cutter with superhard cutting materials Superhard milling

Series

Specific identification

Tool diameter x 0.01 mm

1200	12.00 mm
...	...

Length of cutting edge *

A	0 - 5 mm
B	5.1 - 10 mm
C	10.1 - 15 mm
D	15.1 - 20 mm
E	20.1 - 25 mm
...	...

Number of teeth

Z01	Number of teeth = 1
Z02	Number of teeth = 2
Z03	Number of teeth = 3
Z07	Number of teeth = 7
ZMV	Multi-tooth, medium tooth
ZGV	Multi-tooth, coarse tooth

* Only with milling cutter type SHM
 ** Not applicable for milling cutter type CPM
 *** For milling cutter type CPM, the shank form corresponds to the CFS connection size

CFS replaceable head holders

C F S - **1 0 1** - **N** - **1 2** -

Holder type

CFS	Replaceable head holder Complete Fitting System
-----	----------------------------------------------------

Coolant supply

0	External coolant supply
1	Internal coolant supply

CFS connection size

12	CFS connection size 12 (example)
----	----------------------------------

Series

10	Cylindrical design
20	Conical design
40	Conical design, optimised for SPM replaceable head milling cutter

Design

N	Standard design
---	-----------------

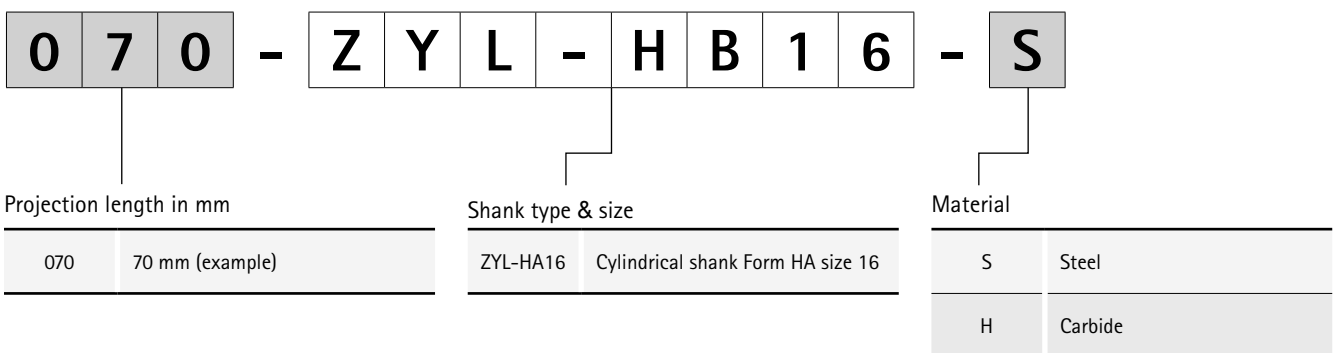
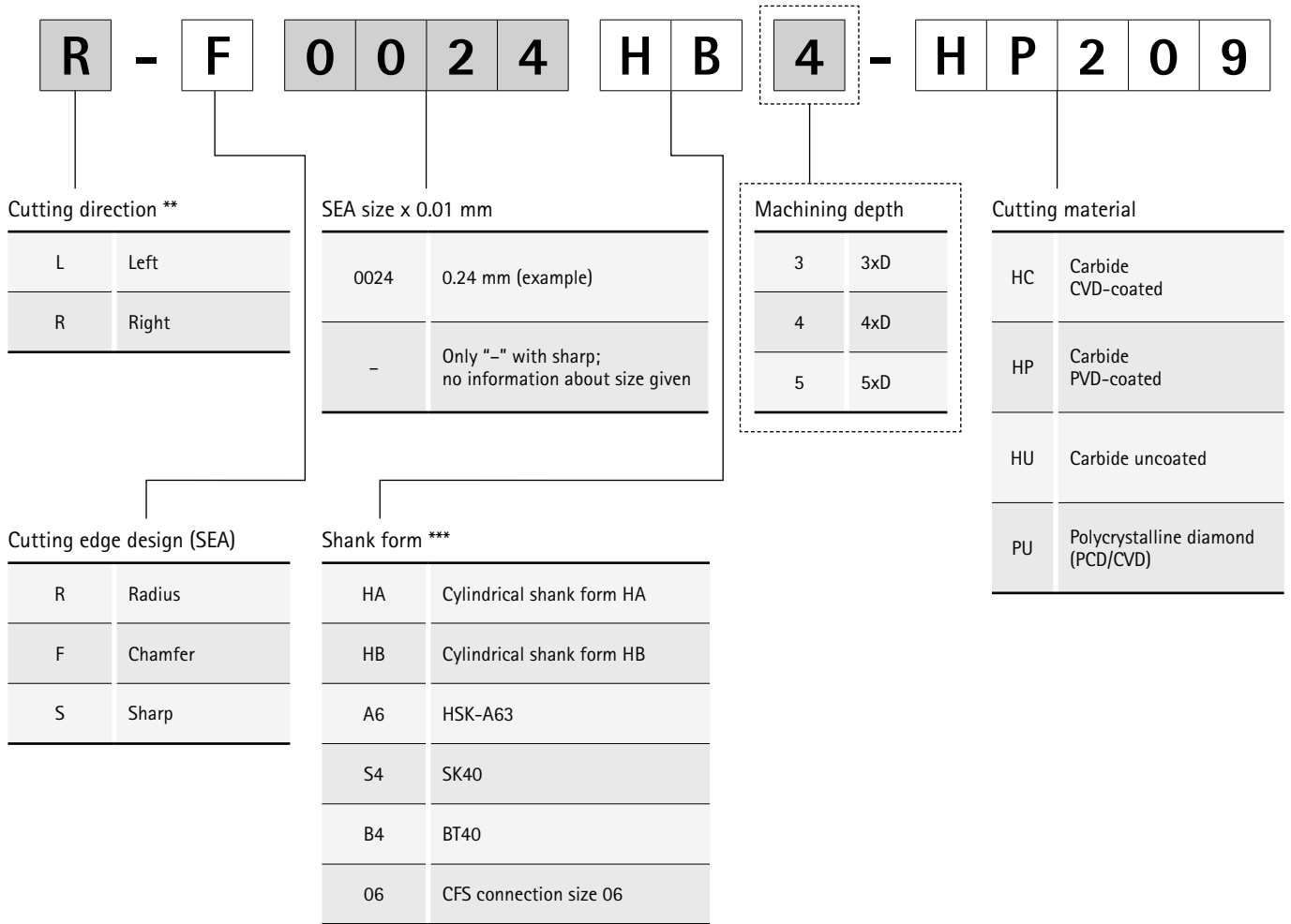

Product ID codes

End milling cutter with fixed cutting edges



Type of milling cutter

MBN	Ball nose cutter Die Et Mould – Ball Nose
MCR	Corner radius milling cutter Die Et Mould – corner radius
MCS	Shoulder radius milling cutter Die Et Mould – circle segment
MHF	High-feed milling cutter Die Et Mould – high feed

Tool diameter x 0.1 mm

040	Milling cutter $\varnothing = 4.0$ mm
...	...

Radius x 0.01 mm

0050	Radius = 0.5 mm
------	-----------------

Radius x 0.1 mm

	PR _{CAM} for milling cutter type "MHF"
--	-------------------------------------------------

Series

100	Continuous
101	
...	
999	

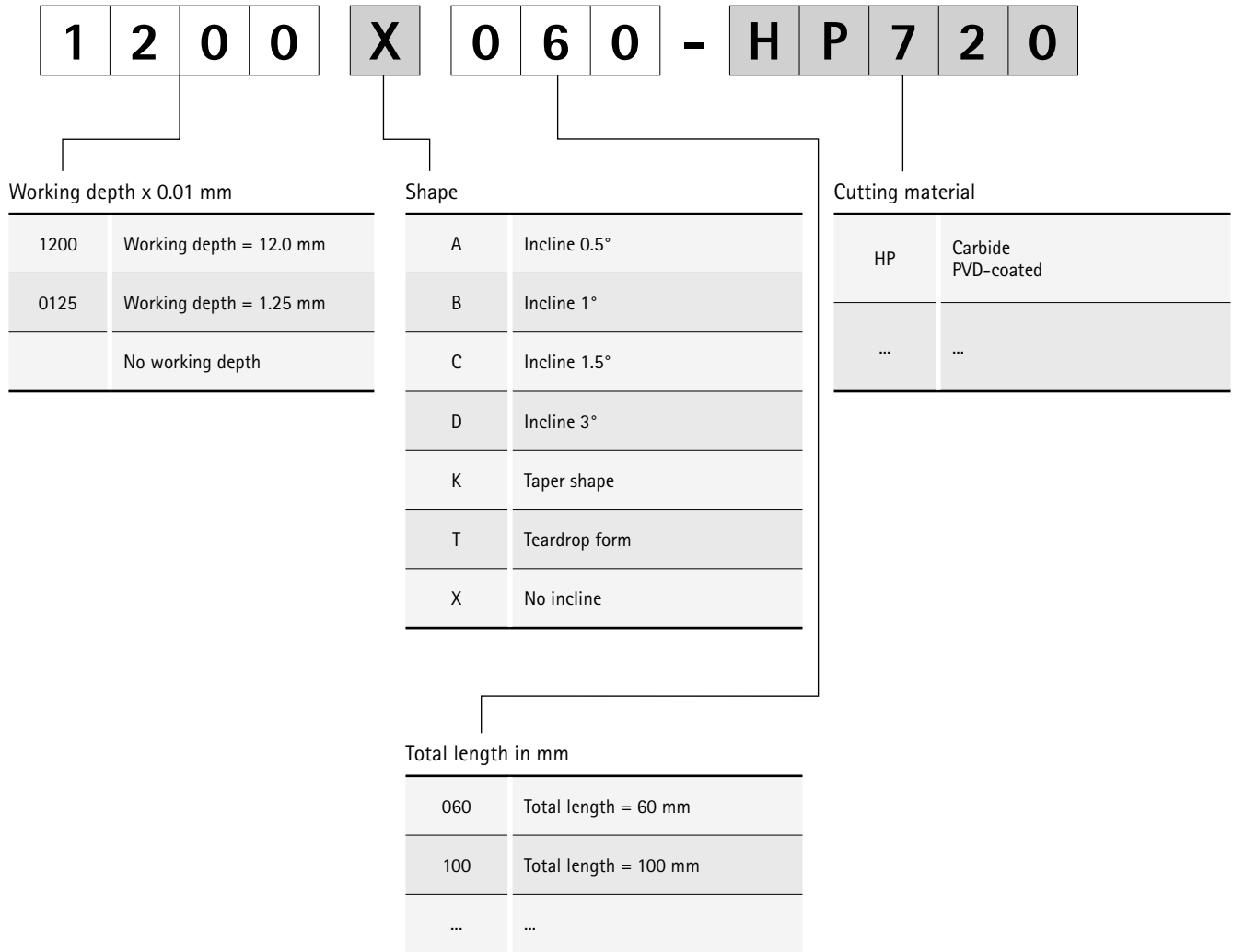



SHOULDER MILLING CUTTERS – UNIVERSAL MACHINING



Universal application

OptiMill-Uni-HPC-Plus	36
CPMill-Uni-HPC	44
OptiMill-Uni-HPC-Slot CPMill-Uni-HPC-Slot	45
OptiMill-Uni-HPC-Pocket	47
OptiMill-Uni-HPC-Silent	51
ECU-Mill-Uni-LV	52

Hardened steel

OptiMill-Hardened	54
-------------------------	----

Inox

OptiMill-Inox-HPC	56
-------------------------	----

Non-ferrous metals

OptiMill-Alu-HPC	57
OptiMill-Alu-HPC-Pocket	58
OptiMill-SPM	60
OptiMill-Diamond-SPM	61
OptiMill-Diamond type 50	63
OptiMill-Diamond type 51	64
OptiMill-Diamond type 53	65
OptiMill-Diamond type 57	66
OptiMill-Mono-Alu	68

Plastics and composite materials

OptiMill-Composite-Speed-Plus	70
OptiMill-Composite-Micro	74
OptiMill-Composite-TwinCut	75
OptiMill-Thermoplastic-FR	76
OptiMill-Mono-Plastic	77

Technical appendix

Cutting data recommendations	78
------------------------------------	----

OptiMill®-Uni-HPC-Plus

Shoulder milling cutter, short design
SCM760

Design:

Diameter of milling cutter: 3.00 - 20.00 mm
Cutting material: HP920
Number of cutting edges: 4
Helix angle: 36°/38°
Special features: Unequal spacing, rounding the cutting edge

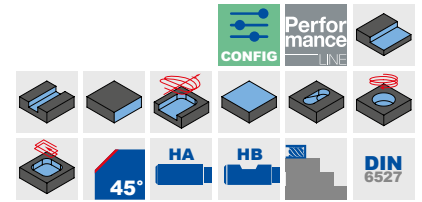
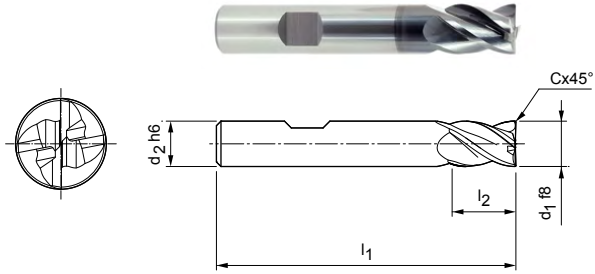

Preferred series in stock

Dimensions					z	Specification	Order no.
d ₁ f8	d ₂ h6	l ₁	l ₂	Cx45°			
3,00	6	50	6	0,06	4	SCM760-0300Z04R-F0006HB-HP920	30787363
4,00	6	54	8	0,08	4	SCM760-0400Z04R-F0008HB-HP920	30787364
5,00	6	54	9	0,10	4	SCM760-0500Z04R-F0010HB-HP920	30787365
6,00	6	54	10	0,12	4	SCM760-0600Z04R-F0012HB-HP920	30787366
8,00	8	58	12	0,16	4	SCM760-0800Z04R-F0016HB-HP920	30787367
10,00	10	66	14	0,20	4	SCM760-1000Z04R-F0020HB-HP920	30787368
12,00	12	73	16	0,24	4	SCM760-1200Z04R-F0024HB-HP920	30787369
14,00	14	73	16	0,28	4	SCM760-1400Z04R-F0028HB-HP920	30787370
16,00	16	82	22	0,32	4	SCM760-1600Z04R-F0032HB-HP920	30787371
18,00	18	82	22	0,36	4	SCM760-1800Z04R-F0036HB-HP920	30787372
20,00	20	92	26	0,40	4	SCM760-2000Z04R-F0040HB-HP920	30787373

Configurable features



Shank form:
Shank form: HA



Specification:
SCM760-0300Z04R-F0006[shank form]-HP920

Example:

SCM760-0300Z04R-F0006HA-HP920

Shank form HA

Dimensions in mm.

For cutting data recommendations, see end of chapter.

Special designs and other coatings available upon request.

OptiMill®-Uni-HPC-Plus

Shoulder milling cutter, long design with neck, design with chamfer / small chamfer
SCM770

Design:

Diameter of milling cutter: 2.50 - 25.00 mm
Cutting material: HP920
Number of cutting edges: 4
Helix angle: 36°/38°
Special features: Unequal spacing, rounding the cutting edge

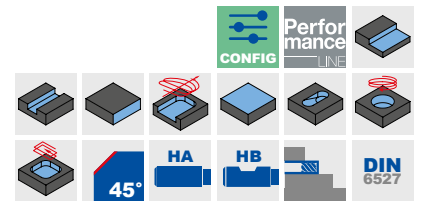
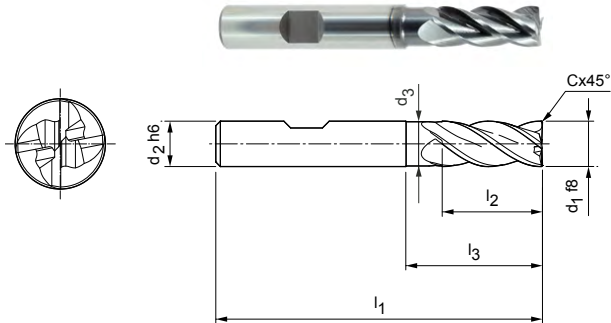

Design with chamfer | Preferred series in stock

Dimensions							z	Specification	Order no.
d ₁ f8	d ₂ h6	d ₃	l ₁	l ₂	l ₃	Cx45°			
2,50*	6	-	57	8	-	0,05	4	SCM770-0250Z04R-F0005HB-HP920	30787374
3,00*	6	-	57	8	-	0,06	4	SCM770-0300Z04R-F0006HB-HP920	30787375
4,00*	6	-	57	11	-	0,08	4	SCM770-0400Z04R-F0008HB-HP920	30787376
5,00*	6	-	57	13	-	0,10	4	SCM770-0500Z04R-F0010HB-HP920	30787377
6,00	6	5,8	57	13	20	0,12	4	SCM770-0600Z04R-F0012HB-HP920	30787378
7,00	8	6,8	63	16	25	0,14	4	SCM770-0700Z04R-F0014HB-HP920	30787379
8,00	8	7,8	63	21	25	0,16	4	SCM770-0800Z04R-F0016HB-HP920	30787380
9,00	10	8,8	72	22	30	0,18	4	SCM770-0900Z04R-F0018HB-HP920	30787381
10,00	10	9,8	72	22	30	0,20	4	SCM770-1000Z04R-F0020HB-HP920	30787382
12,00	12	11,8	83	26	36	0,24	4	SCM770-1200Z04R-F0024HB-HP920	30787383
14,00	14	13,8	83	26	36	0,28	4	SCM770-1400Z04R-F0028HB-HP920	30787390
16,00	16	15,8	92	36	42	0,32	4	SCM770-1600Z04R-F0032HB-HP920	30787391
18,00	18	17,8	92	36	47	0,36	4	SCM770-1800Z04R-F0036HB-HP920	30787392
20,00	20	19,8	104	41	55	0,40	4	SCM770-2000Z04R-F0040HB-HP920	30787393
25,00	25	24,5	136	68	80	0,50	4	SCM770-2500Z04R-F0050HB-HP920	30787394

Design with small chamfer | Preferred series in stock

6,00	6	5,8	57	13	20	0,10	4	SCM770-0600Z04R-F0010HB-HP920	31243605
8,00	8	7,8	63	21	25	0,10	4	SCM770-0800Z04R-F0010HB-HP920	31243606
10,00	10	9,8	72	22	30	0,10	4	SCM770-1000Z04R-F0010HB-HP920	31243608
12,00	12	11,8	83	26	36	0,10	4	SCM770-1200Z04R-F0010HB-HP920	31243609
14,00	14	13,8	83	26	36	0,10	4	SCM770-1400Z04R-F0010HB-HP920	31243610
16,00	16	15,8	92	36	42	0,10	4	SCM770-1600Z04R-F0010HB-HP920	31243611
20,00	20	19,8	104	41	55	0,10	4	SCM770-2000Z04R-F0010HB-HP920	31243612

Configurable features



Shank form:
Shank form: HA



Specification:
SCM770-0250Z04R-F0005[shank form]-HP920

Example:

SCM770-0250Z04R-F0005HA-HP920

Shank form HA

Dimensions in mm.

* Design without neck.

For cutting data recommendations, see end of chapter.

Special designs and other coatings available upon request.

OptiMill®-Uni-HPC-Plus

Shoulder milling cutter, long design with neck, design with corner radius
SCM770

Design:

Diameter of milling cutter: 2.50 - 25.00 mm
Cutting material: HP920
Number of cutting edges: 4
Helix angle: 36°/38°
Special features: Unequal spacing, rounding the cutting edge

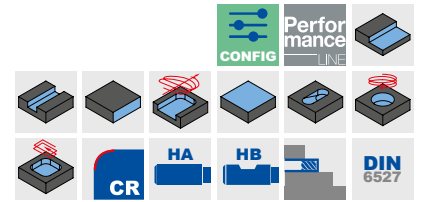
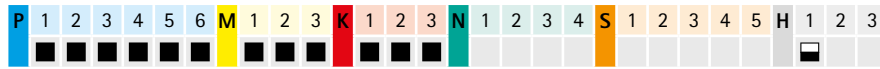
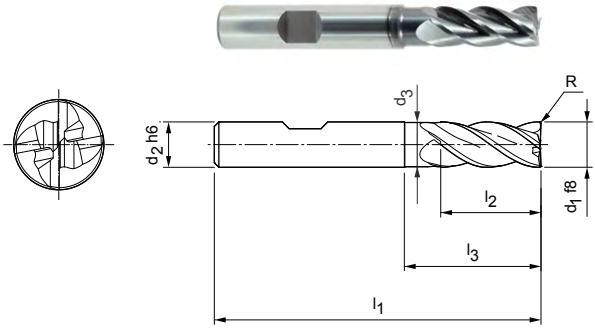

Design with radius | Preferred series in stock

Dimensions							z	Specification	Order no.
d1 f8	d2 h6	d3	l1	l2	l3	R			
4,00*	6	-	57	11	-	0,4	4	SCM770-0400Z04R-R0040HB-HP920	30787434
4,00*	6	-	57	11	-	0,5	4	SCM770-0400Z04R-R0050HB-HP920	30787435
4,00*	6	-	57	11	-	1	4	SCM770-0400Z04R-R0100HB-HP920	30787436
5,00*	6	-	57	13	-	0,5	4	SCM770-0500Z04R-R0050HB-HP920	30787437
5,00*	6	-	57	13	-	1	4	SCM770-0500Z04R-R0100HB-HP920	30787438
6,00	6	5,8	57	13	20	0,5	4	SCM770-0600Z04R-R0050HB-HP920	30787439
6,00	6	5,8	57	13	20	1	4	SCM770-0600Z04R-R0100HB-HP920	30787440
6,00	6	5,8	57	13	20	1,5	4	SCM770-0600Z04R-R0150HB-HP920	30787441
6,00	6	5,8	57	13	20	2	4	SCM770-0600Z04R-R0200HB-HP920	30787442
8,00	8	7,8	63	21	25	0,5	4	SCM770-0800Z04R-R0050HB-HP920	30787443
8,00	8	7,8	63	21	25	1	4	SCM770-0800Z04R-R0100HB-HP920	30787444
8,00	8	7,8	63	21	25	1,5	4	SCM770-0800Z04R-R0150HB-HP920	30787445
8,00	8	7,8	63	21	25	2	4	SCM770-0800Z04R-R0200HB-HP920	30787446
8,00	8	7,8	63	21	25	2,5	4	SCM770-0800Z04R-R0250HB-HP920	30787447
8,00	8	7,8	63	21	25	3	4	SCM770-0800Z04R-R0300HB-HP920	30787448
10,00	10	9,8	72	22	30	0,5	4	SCM770-1000Z04R-R0050HB-HP920	30787449
10,00	10	9,8	72	22	30	1	4	SCM770-1000Z04R-R0100HB-HP920	30787450
10,00	10	9,8	72	22	30	1,5	4	SCM770-1000Z04R-R0150HB-HP920	30787451
10,00	10	9,8	72	22	30	2	4	SCM770-1000Z04R-R0200HB-HP920	30787452
10,00	10	9,8	72	22	30	2,5	4	SCM770-1000Z04R-R0250HB-HP920	30787453
10,00	10	9,8	72	22	30	3	4	SCM770-1000Z04R-R0300HB-HP920	30787454
12,00	12	11,8	83	26	36	0,5	4	SCM770-1200Z04R-R0050HB-HP920	30787455
12,00	12	11,8	83	26	36	1	4	SCM770-1200Z04R-R0100HB-HP920	30787456
12,00	12	11,8	83	26	36	1,5	4	SCM770-1200Z04R-R0150HB-HP920	30787457
12,00	12	11,8	83	26	36	2	4	SCM770-1200Z04R-R0200HB-HP920	30787458
12,00	12	11,8	83	26	36	2,5	4	SCM770-1200Z04R-R0250HB-HP920	30787459
12,00	12	11,8	83	26	36	3	4	SCM770-1200Z04R-R0300HB-HP920	30787460
12,00	12	11,8	83	26	36	4	4	SCM770-1200Z04R-R0400HB-HP920	30787461
16,00	16	15,8	92	36	42	0,5	4	SCM770-1600Z04R-R0050HB-HP920	30787462
16,00	16	15,8	92	36	42	1	4	SCM770-1600Z04R-R0100HB-HP920	30787463
16,00	16	15,8	92	36	42	2	4	SCM770-1600Z04R-R0200HB-HP920	30787464
16,00	16	15,8	92	36	42	2,5	4	SCM770-1600Z04R-R0250HB-HP920	30787465
16,00	16	15,8	92	36	42	3	4	SCM770-1600Z04R-R0300HB-HP920	30787466
16,00	16	15,8	92	36	42	4	4	SCM770-1600Z04R-R0400HB-HP920	30787467
20,00	20	19,8	104	41	52	1	4	SCM770-2000Z04R-R0100HB-HP920	30787468

Design with radius | Preferred series in stock

Dimensions							z	Specification	Order no.
d ₁ f8	d ₂ h6	d ₃	l ₁	l ₂	l ₃	R			
20,00	20	19,8	104	41	52	2	4	SCM770-2000Z04R-R0200HB-HP920	30787469
20,00	20	19,8	104	41	52	3	4	SCM770-2000Z04R-R0300HB-HP920	30787470
20,00	20	19,8	104	41	52	4	4	SCM770-2000Z04R-R0400HB-HP920	30787471

Configurable features



Shank form:
Shank form: HA



Specification:
SCM770-0400Z04R-R0040[shank form]-HP920

Example:
SCM770-0400Z04R-R0040**HA**-HP920

Shank form HA

Dimensions in mm.

* Design without neck.

For cutting data recommendations, see end of chapter.

Special designs and other coatings available upon request.

OptiMill®-Uni-HPC-Plus

Shoulder milling cutter, overlong design with neck, design with chamfer
SCM720

Design:

Diameter of milling cutter: 5.00 - 25.00 mm
Cutting material: HP920
Number of cutting edges: 4
Helix angle: 36°/38°
Special features: Unequal spacing, rounding the cutting edge

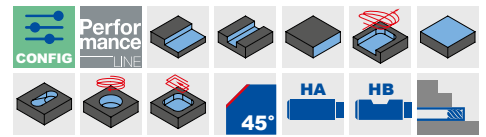
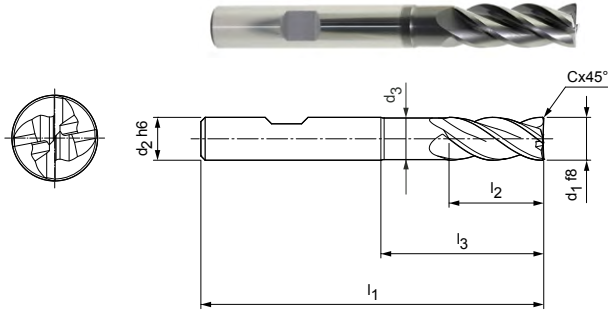

Preferred series in stock

Dimensions							z	Specification	Order no.
d1 f8	d2 h6	d3	l1	l2	l3	Cx45°			
6,00	6	5,8	62	13	25	0,12	4	SCM720-0600Z04R-F0012HB-HP920	30652409
8,00	8	7,7	68	21	30	0,16	4	SCM720-0800Z04R-F0016HB-HP920	30652410
10,00	10	9,7	80	22	38	0,20	4	SCM720-1000Z04R-F0020HB-HP920	30652411
12,00	12	11,6	93	26	46	0,24	4	SCM720-1200Z04R-F0024HB-HP920	30652412
14,00	14	13,6	99	26	52	0,28	4	SCM720-1400Z04R-F0028HB-HP920	30652413
16,00	16	15,5	108	36	58	0,32	4	SCM720-1600Z04R-F0032HB-HP920	30652414
18,00	18	17,5	117	36	67	0,36	4	SCM720-1800Z04R-F0036HB-HP920	30652415
20,00	20	19,5	126	41	74	0,40	4	SCM720-2000Z04R-F0040HB-HP920	30652416
25,00	25	24	150	50	92	0,50	4	SCM720-2500Z04R-F0050HB-HP920	30652417

Available on request

5,00	6	4,8	62	13	24	0,10	4	SCM720-0500Z04R-F0010HB-HP920	30652408
------	---	-----	----	----	----	------	---	-------------------------------	----------

Configurable features

Shank form:
Shank form: HA

Specification:
SCM720-0600Z04R-F0012[shank form]-HP920

Example:

SCM720-0600Z04R-F0012HA-HP920

Shank form HA

Dimensions in mm.

For cutting data recommendations, see end of chapter.

Special designs and other coatings available upon request.

OptiMill®-Uni-HPC-Plus

Shoulder milling cutter, overlong design with neck, design with corner radius
SCM720

Design:

Diameter of milling cutter: 4.00 - 25.00 mm
Cutting material: HP920
Number of cutting edges: 4
Helix angle: 36°/38°
Special features: Unequal spacing, rounding the cutting edge

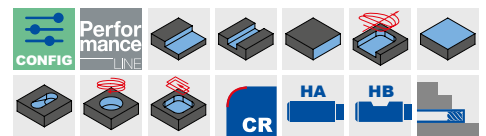
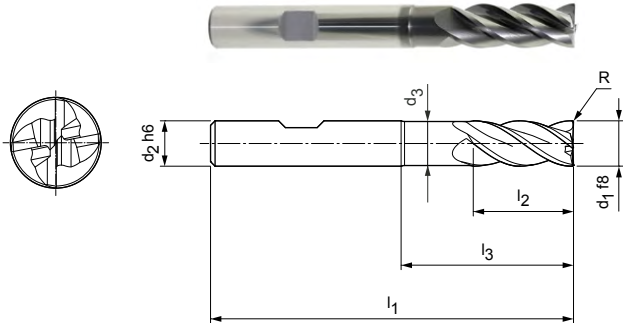

Preferred series in stock

Dimensions							z	Specification	Order no.
d1 f8	d2 h6	d3	l1	l2	l3	R			
4,00	6	3,8	62	11	22	0,5	4	SCM720-0400Z04R-R0050HB-HP920	31046163
4,00	6	3,8	62	11	22	1	4	SCM720-0400Z04R-R0100HB-HP920	31046164
5,00	6	4,8	62	13	24	0,5	4	SCM720-0500Z04R-R0050HB-HP920	31046165
5,00	6	4,8	62	13	24	1	4	SCM720-0500Z04R-R0100HB-HP920	31046166
6,00	6	5,8	62	13	25	0,5	4	SCM720-0600Z04R-R0050HB-HP920	31046167
6,00	6	5,8	62	13	25	1	4	SCM720-0600Z04R-R0100HB-HP920	31046168
6,00	6	5,8	62	13	25	2	4	SCM720-0600Z04R-R0200HB-HP920	31046169
8,00	8	7,7	68	21	30	1	4	SCM720-0800Z04R-R0100HB-HP920	31046170
8,00	8	7,7	68	21	30	2	4	SCM720-0800Z04R-R0200HB-HP920	31046171
10,00	10	9,7	80	22	38	0,5	4	SCM720-1000Z04R-R0050HB-HP920	31046172
10,00	10	9,7	80	22	38	1	4	SCM720-1000Z04R-R0100HB-HP920	31046173
10,00	10	9,7	80	22	38	1,5	4	SCM720-1000Z04R-R0150HB-HP920	31046174
10,00	10	9,7	80	22	38	2	4	SCM720-1000Z04R-R0200HB-HP920	31046175
10,00	10	9,7	80	22	38	3	4	SCM720-1000Z04R-R0300HB-HP920	31046176
12,00	12	11,6	93	26	46	0,5	4	SCM720-1200Z04R-R0050HB-HP920	31046177
12,00	12	11,6	93	26	46	1	4	SCM720-1200Z04R-R0100HB-HP920	31046178
12,00	12	11,6	93	26	46	1,5	4	SCM720-1200Z04R-R0150HB-HP920	31046179
12,00	12	11,6	93	26	46	2	4	SCM720-1200Z04R-R0200HB-HP920	31046180
12,00	12	11,6	93	26	46	3	4	SCM720-1200Z04R-R0300HB-HP920	31046181
16,00	16	15,5	108	36	58	0,5	4	SCM720-1600Z04R-R0050HB-HP920	31046182
16,00	16	15,5	108	36	58	1	4	SCM720-1600Z04R-R0100HB-HP920	31046183
16,00	16	15,5	108	36	58	2	4	SCM720-1600Z04R-R0200HB-HP920	31046184
16,00	16	15,5	108	36	58	4	4	SCM720-1600Z04R-R0400HB-HP920	31046185
20,00	20	19,5	126	41	74	1	4	SCM720-2000Z04R-R0100HB-HP920	31046186
20,00	20	19,5	126	41	74	2	4	SCM720-2000Z04R-R0200HB-HP920	31046187
20,00	20	19,5	126	41	74	4	4	SCM720-2000Z04R-R0400HB-HP920	31046188

Configurable features

Shank form:
Shank form: HA

Specification:
SCM720-0400Z04R-R0050[shank form]-HP920

Example:

SCM720-0400Z04R-R0050**HA**-HP920

Shank form HA

Dimensions in mm.

* Design without neck.

For cutting data recommendations, see end of chapter.

Special designs and other coatings available upon request.

OptiMill®-Uni-HPC-Plus

Shoulder milling cutter, extra long design with neck
SCM740

Design:

Diameter of milling cutter: 5.00 - 25.00 mm
Cutting material: HP920
Number of cutting edges: 4
Helix angle: 36°/38°
Special features: Unequal spacing, rounding the cutting edge

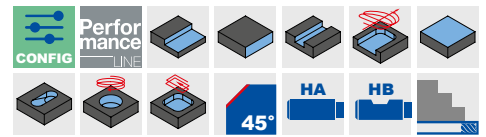
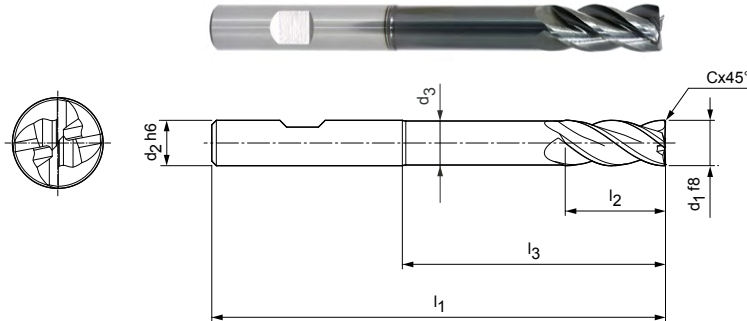

Preferred series in stock

Dimensions							z	Specification	Order no.
d ₁ f8	d ₂ h6	d ₃	l ₁	l ₂	l ₃	Cx45°			
5,00	6	4,8	80	13	41	0,10	4	SCM740-0500Z04R-F0010HB-HP920	30652418
6,00	6	5,8	80	13	42	0,12	4	SCM740-0600Z04R-F0012HB-HP920	30652419
8,00	8	7,7	100	21	62	0,16	4	SCM740-0800Z04R-F0016HB-HP920	30652420
10,00	10	9,7	100	22	58	0,20	4	SCM740-1000Z04R-F0020HB-HP920	30652421
12,00	12	11,6	120	26	73	0,24	4	SCM740-1200Z04R-F0024HB-HP920	30652422
14,00	14	13,6	120	26	73	0,28	4	SCM740-1400Z04R-F0028HB-HP920	30652423
16,00	16	15,5	150	36	100	0,32	4	SCM740-1600Z04R-F0032HB-HP920	30652424
20,00	20	19,5	150	41	98	0,40	4	SCM740-2000Z04R-F0040HB-HP920	30652426

Available on request

18,00	18	17,5	150	36	100	0,36	4	SCM740-1800Z04R-F0036HB-HP920	30652425
25,00	25	24	175	50	117	0,50	4	SCM740-2500Z04R-F0050HB-HP920	30652427

Configurable features



Shank form:
Shank form: HA



Specification:
SCM740-0500Z04R-F0010[shank form]-HP920

Example:

SCM740-0500Z04R-F0010HA-HP920

Shank form HA

Dimensions in mm.

For cutting data recommendations, see end of chapter.

Special designs and other coatings available upon request.

OptiMill®-Uni-HPC-Plus

Shoulder milling cutter, long design with neck
SCM772

Design:

Diameter of milling cutter: 1.00 - 20.00 mm
Cutting material: HP213/HP723
Number of cutting edges: 2
Helix angle: 36°/38°
Special features: Unequal spacing, rounding the cutting edge

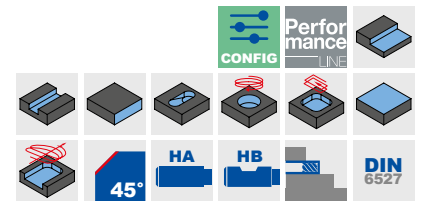
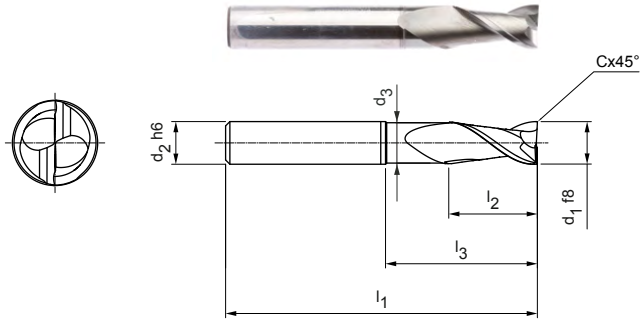

Preferred series in stock

Dimensions							z	Specification	Order no.
d ₁ f8	d ₂ h6	d ₃	l ₁	l ₂	l ₃	Cx45°			
1,00	3	0,97	38	3	5	0,025	2	SCM772-0100Z02R-F0005HA-HP213	31205147
2,00	3	1,9	38	4	8	0,05	2	SCM772-0200Z02R-F0005HA-HP213	31205148
3,00	6	2,8	57	7	13	0,10	2	SCM772-0300Z02R-F0010HA-HP723	31205149
4,00	6	3,8	57	8	14	0,10	2	SCM772-0400Z02R-F0010HA-HP723	31205180
5,00	6	4,8	57	10	15,5	0,10	2	SCM772-0500Z02R-F0010HA-HP723	31205181
6,00	6	5,8	57	10	20	0,10	2	SCM772-0600Z02R-F0010HA-HP723	31205182
8,00	8	7,8	63	16	25	0,10	2	SCM772-0800Z02R-F0010HA-HP723	31205183
10,00	10	9,8	72	19	30	0,10	2	SCM772-1000Z02R-F0010HA-HP723	31205184
12,00	12	11,8	83	22	36	0,10	2	SCM772-1200Z02R-F0010HA-HP723	31205185
16,00	16	15,8	92	26	42	0,10	2	SCM772-1600Z02R-F0010HA-HP723	31205186

Available on request

20,00	20	19,8	104	32	52	0,10	2	SCM772-2000Z02R-F0010HA-HP723	31205187
-------	----	------	-----	----	----	------	---	-------------------------------	----------

Configurable features*



Shank form:
Shank form: HB



Specification:
SCM772-0100Z02R-F0005[shank form]-HP213

Example:

SCM772-0100Z02R-F0005HB-HP213

Shank form HB

Dimensions in mm.

* Configurable features valid from d₁ = 3 mm.

For cutting data recommendations, see end of chapter.

Special designs and other coatings available upon request.

CPMill®-Uni-HPC

Design with CFS connection
CPM100

Design:

Diameter of milling cutter: 8.00 – 20.00 mm
Cutting material: HP383
Number of cutting edges: 4
Helix angle: 37°
Special features: Unequal spacing

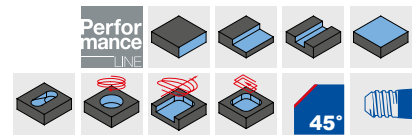
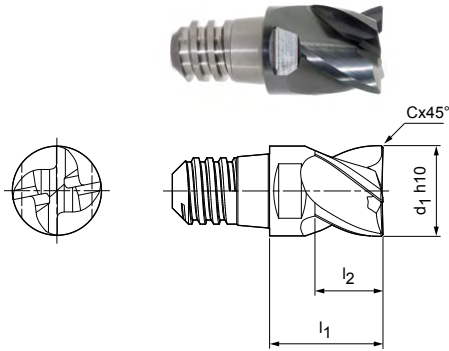

Preferred series in stock

Dimensions					z	ap max.	SW	Specification	Order no.
d1 h10	CFS size	l1	l2	Cx45°					
8,00	6	11	6	0,16	4	4,5	SW 6	CPM100-0800Z04-F0016-06-HP383	30371373
10,00	8	13	7,5	0,20	4	5,6	SW 8	CPM100-1000Z04-F0020-08-HP383	30371374
12,00	10	16	9	0,24	4	6,8	SW 10	CPM100-1200Z04-F0024-10-HP383	30371375
16,00	12	20	12	0,32	4	9	SW 13	CPM100-1600Z04-F0032-12-HP383	30371376
20,00	16	25	15	0,40	4	11,3	SW 16	CPM100-2000Z04-F0040-16-HP383	30371378

Accessories

	CFS replaceable head holders CFS101 CFS201	Page 218
-------------------------------------------------------------------------------------	-------------------------------------------------	----------

Dimensions in mm.
For cutting data recommendations, see end of chapter.
Special designs and other coatings available upon request.

OptiMill®-Uni-HPC-Slot

Shoulder milling cutter, long design with neck
SCM250

Design:

Diameter of milling cutter: 1.00 - 20.00 mm
Cutting material: HP213/HP922
Number of cutting edges: 3
Helix angle: 42° - 43°
Special features: Unequal spacing

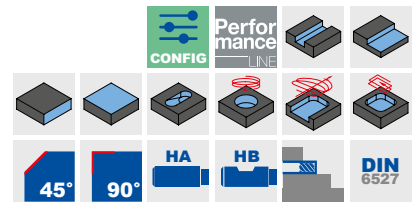
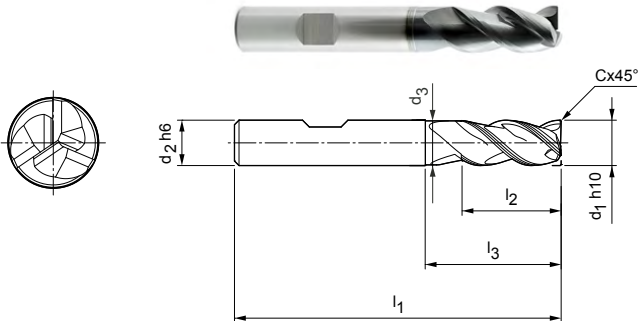

Preferred series in stock

Dimensions							z	Specification	Order no.
d ₁ h10	d ₂ h6	d ₃	l ₁	l ₂	l ₃	Cx45°			
1,00	6	0,9	54	2,5	4	-	3	SCM250-0100Z03R-S-HB-HP922	30595972
1,50	6	1,4	54	4	6	-	3	SCM250-0150Z03R-S-HB-HP922	30504879
2,00	6	1,9	54	5	8	-	3	SCM250-0200Z03R-S-HB-HP922	30504885
2,50	6	2,4	54	6,5	10	-	3	SCM250-0250Z03R-S-HB-HP922	30596272
3,00	6	2,8	57	8	12,5	0,06	3	SCM250-0300Z03R-F0006HB-HP213	30393565
4,00	6	3,8	57	11	15	0,08	3	SCM250-0400Z03R-F0008HB-HP213	30393566
5,00	6	4,8	57	13	16	0,10	3	SCM250-0500Z03R-F0010HB-HP213	30393567
6,00	6	5,8	57	13	20	0,12	3	SCM250-0600Z03R-F0012HB-HP213	30393568
8,00	8	7,8	63	21	27	0,16	3	SCM250-0800Z03R-F0016HB-HP213	30393569
10,00	10	9,8	72	22	30	0,20	3	SCM250-1000Z03R-F0020HB-HP213	30393570
12,00	12	11,8	83	26	36	0,24	3	SCM250-1200Z03R-F0024HB-HP213	30393571
16,00	16	15,8	92	36	44	0,32	3	SCM250-1600Z03R-F0032HB-HP213	30393573
18,00	18	17,8	92	36	44	0,36	3	SCM250-1800Z03R-F0036HB-HP213	30393574
20,00	20	19,8	104	41	55	0,40	3	SCM250-2000Z03R-F0040HB-HP213	30393575

Available on request

14,00	14	13,8	83	26	36	0,28	3	SCM250-1400Z03R-F0028HB-HP213	30393572
-------	----	------	----	----	----	------	---	-------------------------------	----------

Configurable features



Shank form:
Shank form: HA



Specification:
SCM250-0300Z03R-F0006[shank form]-HP213

Example:
SCM250-0300Z03R-F0006HA-HP213

Shank form HA

Dimensions in mm.
For cutting data recommendations, see end of chapter.
Special designs and other coatings available upon request.

CPMill®-Uni-HPC-Slot

Design with CFS connection
CPM110

Design:

Diameter of milling cutter: 8.00 – 25.00 mm
Cutting material: HP383
Number of cutting edges: 3
Helix angle: 41°
Special features: Unequal spacing

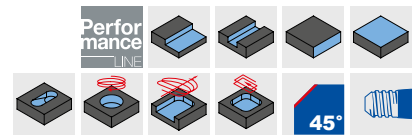
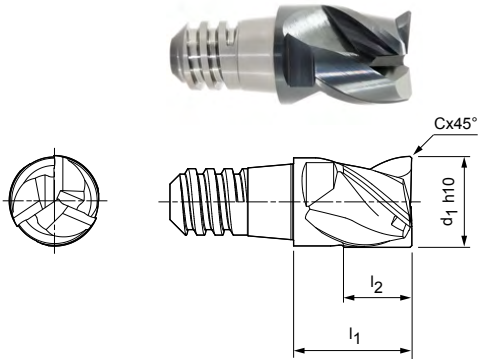

Preferred series in stock

Dimensions					z	ap max.	SW	Specification	Order no.
d1 h10	CFS size	l1	l2	Cx45°					
8,00	6	11	6	0,16	3	4,5	SW 6	CPM110-0800Z03-F0016-06-HP383	30371366
10,00	8	13	7,5	0,20	3	5,6	SW 8	CPM110-1000Z03-F0020-08-HP383	30371367
12,00	10	16	9	0,24	3	6,8	SW 10	CPM110-1200Z03-F0024-10-HP383	30371368
16,00	12	20	12	0,32	3	9	SW 13	CPM110-1600Z03-F0032-12-HP383	30371369
20,00	16	25	15	0,40	3	11,3	SW 16	CPM110-2000Z03-F0040-16-HP383	30371371
25,00	20	32	19	0,50	3	14	SW 21	CPM110-2500Z03-F0050-20-HP383	30371372

Accessories

	CFS replaceable head holders CFS101 CFS201	Page 218
-------------------------------------------------------------------------------------	-------------------------------------------------	----------

Dimensions in mm.
For cutting data recommendations, see end of chapter.
Special designs and other coatings available upon request.

OptiMill®-Uni-HPC-Pocket

Shoulder milling cutter, long design with neck
SCM810

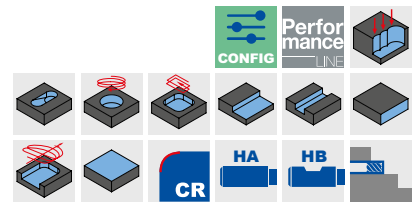
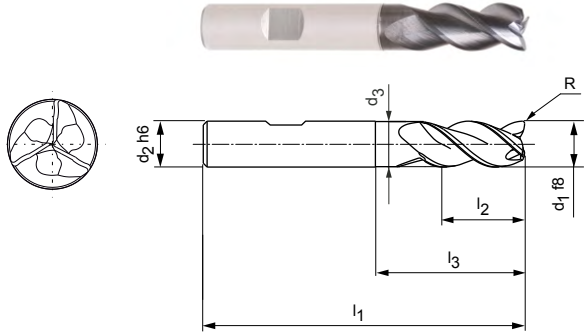

Design:
 Diameter of milling cutter: 3.80 - 20.00 mm
 Cutting material: HP920
 Number of cutting edges: 3
 Helix angle: ~ 42°
 Special features: Face geometry with integrated drill tip

Application:
 Perfect for inclined plunging up to 45°, in helix milling and grooving.

Preferred series in stock

Dimensions							z	Specification	Order no.
d1 f8	d2 h6	d3	l1	l2	l3	R			
3,80	6	3,6	57	10	13	0,19	3	SCM810-0380Z03R-R0019HB-HP920	31031147
4,00	6	3,8	57	11	13	0,2	3	SCM810-0400Z03R-R0020HB-HP920	31031148
4,80	6	4,6	57	11	15,5	0,24	3	SCM810-0480Z03R-R0024HB-HP920	31031149
5,00	6	4,8	57	13	15,5	0,25	3	SCM810-0500Z03R-R0025HB-HP920	31031150
5,70	6	5,5	57	13	19	0,29	3	SCM810-0570Z03R-R0029HB-HP920	30788023
6,00	6	5,8	57	13	19	0,3	3	SCM810-0600Z03R-R0030HB-HP920	30788024
6,70	8	6,5	63	16	25	0,34	3	SCM810-0670Z03R-R0034HB-HP920	30788025
7,00	8	6,8	63	16	25	0,35	3	SCM810-0700Z03R-R0035HB-HP920	30788026
7,70	8	7,5	63	19	25	0,39	3	SCM810-0770Z03R-R0039HB-HP920	30788027
8,00	8	7,8	63	19	25	0,4	3	SCM810-0800Z03R-R0040HB-HP920	30788028
8,70	10	8,5	72	22	30	0,44	3	SCM810-0870Z03R-R0044HB-HP920	30788029
9,00	10	8,8	72	22	30	0,45	3	SCM810-0900Z03R-R0045HB-HP920	30788030
9,70	10	9,5	72	22	30	0,49	3	SCM810-0970Z03R-R0049HB-HP920	30788031
10,00	10	9,8	72	22	30	0,5	3	SCM810-1000Z03R-R0050HB-HP920	30788032
11,70	12	11,5	83	26	36	0,59	3	SCM810-1170Z03R-R0059HB-HP920	30788033
12,00	12	11,8	83	26	36	0,6	3	SCM810-1200Z03R-R0060HB-HP920	30788034
13,70	14	13,5	83	26	36	0,69	3	SCM810-1370Z03R-R0069HB-HP920	30788035
14,00	14	13,8	83	26	36	0,7	3	SCM810-1400Z03R-R0070HB-HP920	30788036
15,50	16	15,3	92	31	42	0,78	3	SCM810-1550Z03R-R0078HB-HP920	30788037
16,00	16	15,8	92	31	42	0,8	3	SCM810-1600Z03R-R0080HB-HP920	30788038
17,50	18	17,3	92	31	42	0,88	3	SCM810-1750Z03R-R0088HB-HP920	30788039
18,00	18	17,8	92	31	42	0,9	3	SCM810-1800Z03R-R0090HB-HP920	30788040
19,50	20	19,3	104	41	52	0,98	3	SCM810-1950Z03R-R0098HB-HP920	30788041
20,00	20	19,8	104	41	52	1	3	SCM810-2000Z03R-R0100HB-HP920	30788042

Configurable features

Shank form:
Shank form: HA

Specification:
SCM810-0380Z03R-R0019[shank form]-HP920

Example:
SCM810-0380Z03R-R0019HA-HP920

Shank form HA

Dimensions in mm.
 For cutting data recommendations, see end of chapter.
 Special designs and other coatings available upon request.

OptiMill®-Uni-HPC-Pocket

Shoulder milling cutter, short design
SCM840

Design:

Diameter of milling cutter: 3.80 – 20.00 mm
Cutting material: HP920
Number of cutting edges: 3
Helix angle: ~ 42°
Special features: Face geometry with integrated drill tip

Application:

Perfect for inclined plunging up to 45°, in helix milling and grooving.

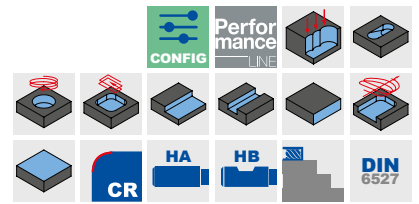
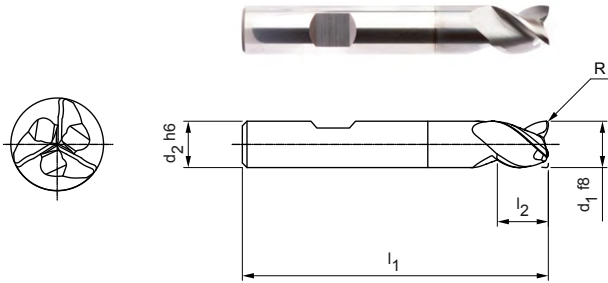

Preferred series in stock

Dimensions						z	Specification	Order no.
d ₁ f8	d ₂ h6	l ₁	l ₂	l ₅	R*			
3,80	6	54	5	10,5	0,12	3	SCM840-0380Z03R-R0012HB-HP920	31031129
4,00	6	54	5	10,5	0,12	3	SCM840-0400Z03R-R0012HB-HP920	31031140
4,80	6	54	6	12,5	0,2	3	SCM840-0480Z03R-R0020HB-HP920	31031141
5,00	6	54	6	12,5	0,2	3	SCM840-0500Z03R-R0020HB-HP920	31031142
5,70	6	54	7	14,5	0,2	3	SCM840-0570Z03R-R0020HB-HP920	30965832
6,00	6	54	7	-	0,2	3	SCM840-0600Z03R-R0020HB-HP920	30965833
6,70	8	58	8	16,5	0,2	3	SCM840-0670Z03R-R0020HB-HP920	30965834
7,00	8	58	8	17	0,2	3	SCM840-0700Z03R-R0020HB-HP920	30965835
7,70	8	58	9	18,5	0,2	3	SCM840-0770Z03R-R0020HB-HP920	30965836
8,00	8	58	9	-	0,2	3	SCM840-0800Z03R-R0020HB-HP920	30965837
8,70	10	66	10	20,5	0,32	3	SCM840-0870Z03R-R0032HB-HP920	30965838
9,00	10	66	10	21	0,32	3	SCM840-0900Z03R-R0032HB-HP920	30965839
9,70	10	66	11	22,5	0,32	3	SCM840-0970Z03R-R0032HB-HP920	30965840
10,00	10	66	11	-	0,32	3	SCM840-1000Z03R-R0032HB-HP920	30953712
11,70	12	73	12	24,5	0,32	3	SCM840-1170Z03R-R0032HB-HP920	30965841
12,00	12	73	12	-	0,32	3	SCM840-1200Z03R-R0032HB-HP920	30948678
13,70	14	75	14	26,5	0,32	3	SCM840-1370Z03R-R0032HB-HP920	30965842
14,00	14	75	14	-	0,32	3	SCM840-1400Z03R-R0032HB-HP920	30965843
15,50	16	82	16	30	0,32	3	SCM840-1550Z03R-R0032HB-HP920	30965844
16,00	16	82	16	-	0,32	3	SCM840-1600Z03R-R0032HB-HP920	30965845
17,50	18	84	18	32	0,32	3	SCM840-1750Z03R-R0032HB-HP920	30965846
19,50	20	92	20	38	0,5	3	SCM840-1950Z03R-R0050HB-HP920	30965848
20,00	20	92	20	-	0,5	3	SCM840-2000Z03R-R0050HB-HP920	30965849

* Corner radius especially for feather key milling according to DIN 6885.

Available on request

18,00	18	84	18	-	0,32	3	SCM840-1800Z03R-R0032HB-HP920	30965847
-------	----	----	----	---	------	---	-------------------------------	----------

Configurable features



Shank form:
Shank form: HA



Specification:
SCM840-0380Z03R-R0012[shank form]-HP920

Example:

SCM840-0380Z03R-R0012**HA**-HP920



Dimensions in mm.

For cutting data recommendations, see end of chapter.

Special designs and other coatings available upon request.



OptiMill®-Uni-HPC-Pocket

Shoulder milling cutter, overlong design with neck
SCM800

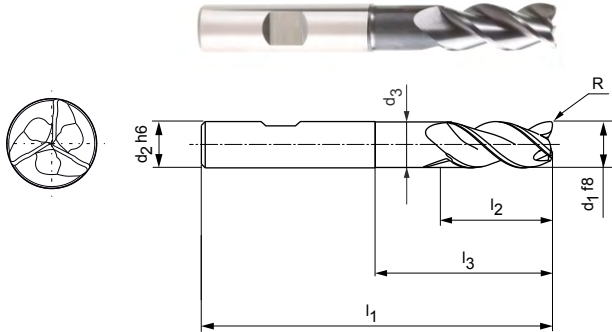

Design:
 Diameter of milling cutter: 5.00 - 20.00 mm
 Cutting material: HP920
 Number of cutting edges: 3
 Helix angle: ~ 42°
 Special features: Face geometry with integrated drill tip

Application:
 Perfect for inclined plunging up to 45°, in helix milling and grooving.

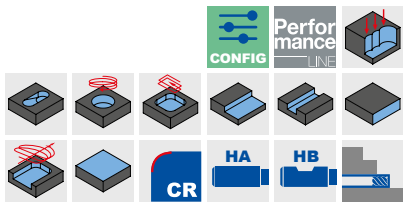

Preferred series in stock

Dimensions							z	Specification	Order no.
d1 f8	d2 h6	d3	l1	l2	l3	R			
5,00	6	4,8	62	13	24	0,25	3	SCM800-0500Z03R-R0025HB-HP920	31031146
5,70	6	5,5	62	13	24	0,29	3	SCM800-0570Z03R-R0029HB-HP920	30787957
6,00	6	5,8	62	13	24	0,3	3	SCM800-0600Z03R-R0030HB-HP920	30787958
6,70	8	6,4	68	16	30	0,34	3	SCM800-0670Z03R-R0034HB-HP920	30787959
7,00	8	6,7	68	16	30	0,35	3	SCM800-0700Z03R-R0035HB-HP920	30787960
7,70	8	7,4	68	21	30	0,39	3	SCM800-0770Z03R-R0039HB-HP920	30787961
8,00	8	7,7	68	21	30	0,4	3	SCM800-0800Z03R-R0040HB-HP920	30787962
8,70	10	8,4	80	22	38	0,44	3	SCM800-0870Z03R-R0044HB-HP920	30787963
9,00	10	8,7	80	22	38	0,45	3	SCM800-0900Z03R-R0045HB-HP920	30787964
9,70	10	9,4	80	22	38	0,49	3	SCM800-0970Z03R-R0049HB-HP920	30787965
10,00	10	9,7	80	22	38	0,5	3	SCM800-1000Z03R-R0050HB-HP920	30787966
11,70	12	11,3	93	26	46	0,59	3	SCM800-1170Z03R-R0059HB-HP920	30787967
12,00	12	11,6	93	26	46	0,6	3	SCM800-1200Z03R-R0060HB-HP920	30787968
13,70	14	13,3	99	26	52	0,69	3	SCM800-1370Z03R-R0069HB-HP920	30787969
14,00	14	13,6	99	26	52	0,7	3	SCM800-1400Z03R-R0070HB-HP920	30787970
15,50	16	15	108	36	58	0,78	3	SCM800-1550Z03R-R0078HB-HP920	30787971
16,00	16	15,5	108	36	58	0,8	3	SCM800-1600Z03R-R0080HB-HP920	30787972
17,50	18	17	117	36	67	0,88	3	SCM800-1750Z03R-R0088HB-HP920	30787973
18,00	18	17,5	117	36	67	0,9	3	SCM800-1800Z03R-R0090HB-HP920	30787974
19,50	20	19	126	41	74	0,98	3	SCM800-1950Z03R-R0098HB-HP920	30787975
20,00	20	19,5	126	41	74	1	3	SCM800-2000Z03R-R0100HB-HP920	30787976

Configurable features

Shank form:
Shank form: HA

Specification:
SCM800-0500Z03R-R0025[shank form]-HP920

Example:
 SCM800-0500Z03R-R0025HA-HP920

Shank form HA

Dimensions in mm.
 For cutting data recommendations, see end of chapter.
 Special designs and other coatings available upon request.

OptiMill®-Uni-HPC-Silent

Shoulder milling cutter, long design with neck
SCM570

Design:

Diameter of milling cutter: 6.00 - 25.00 mm
Cutting material: HP723
Number of cutting edges: 5
Helix angle: 41° - 42°
Special features: Unequal spacing

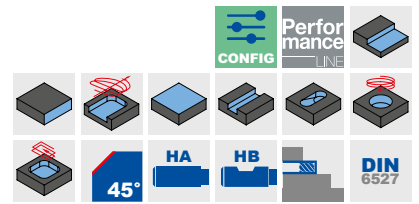
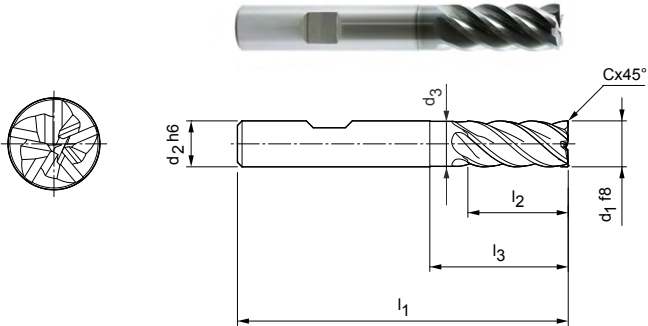

Preferred series in stock

Dimensions							z	Specification	Order no.
d ₁ f8	d ₂ h6	d ₃	l ₁	l ₂	l ₃	Cx45°			
6,00	6	5,8	57	13	19	0,12	5	SCM570-0600Z05R-F0012HB-HP723	30510329
8,00	8	7,8	63	19	25	0,16	5	SCM570-0800Z05R-F0016HB-HP723	30510343
10,00	10	9,8	72	22	30	0,20	5	SCM570-1000Z05R-F0020HB-HP723	30510345
12,00	12	11,8	83	26	36	0,24	5	SCM570-1200Z05R-F0024HB-HP723	30510347
16,00	16	15,8	92	32	42	0,32	5	SCM570-1600Z05R-F0032HB-HP723	30510348
20,00	20	19,8	104	41	52	0,40	5	SCM570-2000Z05R-F0040HB-HP723	30510349
25,00	25	24,5	125	50	65	0,50	5	SCM570-2500Z05R-F0050HB-HP723	30510350

Available on request

14,00	14	13,8	83	26	36	0,28	5	SCM570-1400Z05R-F0028HB-HP723	30671900
18,00	18	17,8	92	32	42	0,36	5	SCM570-1800Z05R-F0036HB-HP723	30583302

Configurable features



Shank form:
Shank form: HA



Specification:
SCM570-0600Z05R-F0012[shank form]-HP723

Example:

SCM570-0600Z05R-F0012HA-HP723

Shank form HA

Dimensions in mm.

For cutting data recommendations, see end of chapter.

Special designs and other coatings available upon request.

ECU-Mill-Uni-LV

Shoulder milling cutter, short design
SCM780

Design:

Diameter of milling cutter: 3.00 - 20.00 mm
Cutting material: HP921
Number of cutting edges: 4
Helix angle: 36°/38.5°
Special features: Unequal spacing

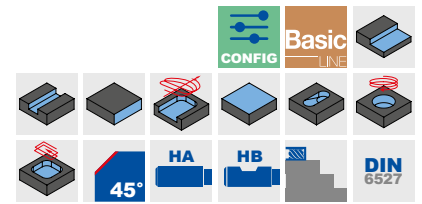
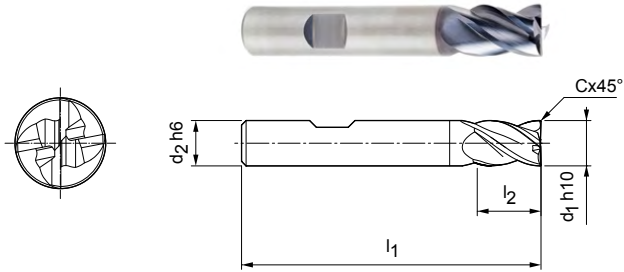

Preferred series in stock

Dimensions					z	Specification	Order no.
d ₁ h10	d ₂ h6	l ₁	l ₂	Cx45°			
3,00	6	50	6	0,06	4	SCM780-0300Z04R-F0006HB-HP921	30656944
4,00	6	54	8	0,08	4	SCM780-0400Z04R-F0008HB-HP921	30656945
5,00	6	54	9	0,10	4	SCM780-0500Z04R-F0010HB-HP921	30656946
6,00	6	54	10	0,12	4	SCM780-0600Z04R-F0012HB-HP921	30656947
8,00	8	58	12	0,16	4	SCM780-0800Z04R-F0016HB-HP921	30656949
10,00	10	66	14	0,20	4	SCM780-1000Z04R-F0020HB-HP921	30656950
12,00	12	73	16	0,24	4	SCM780-1200Z04R-F0024HB-HP921	30656951
16,00	16	82	22	0,32	4	SCM780-1600Z04R-F0032HB-HP921	30656953
20,00	20	92	26	0,40	4	SCM780-2000Z04R-F0040HB-HP921	30656955

Available on request

14,00	14	73	16	0,28	4	SCM780-1400Z04R-F0028HB-HP921	30656952
18,00	18	82	22	0,36	4	SCM780-1800Z04R-F0036HB-HP921	30656954

Configurable features



Shank form:
Shank form: HA



Specification:
SCM780-0300Z04R-F0006[shank form]-HP921

Example:

SCM780-0300Z04R-F0006HA-HP921

Shank form HA

Dimensions in mm.

For cutting data recommendations, see end of chapter.

Special designs and other coatings available upon request.

ECU-Mill-Uni-LV

Shoulder milling cutter, long design with neck
SCM790, follow-up product to OptiMill-Uni (z4)

Design:

Diameter of milling cutter: 3.00 - 20.00 mm
Cutting material: HP921
Number of cutting edges: 4
Helix angle: 36°/38.5°
Special features: Unequal spacing

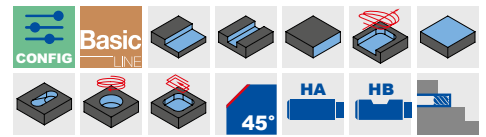
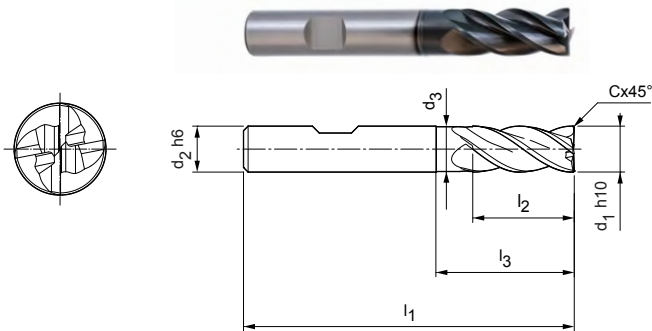

Preferred series in stock

Dimensions							z	Specification	Order no.
d ₁ h10	d ₂ h6	d ₃	l ₁	l ₂	l ₃	Cx45°			
3,00*	6	-	57	8	-	0,06	4	SCM790-0300Z04R-F0006HB-HP921	30656932
4,00*	6	-	57	11	-	0,08	4	SCM790-0400Z04R-F0008HB-HP921	30656933
5,00*	6	-	57	13	-	0,10	4	SCM790-0500Z04R-F0010HB-HP921	30656934
6,00	6	5,8	57	13	20	0,12	4	SCM790-0600Z04R-F0012HB-HP921	30656935
8,00	8	7,8	63	21	25	0,16	4	SCM790-0800Z04R-F0016HB-HP921	30656936
10,00	10	9,8	72	22	30	0,20	4	SCM790-1000Z04R-F0020HB-HP921	30656937
12,00	12	11,8	83	26	36	0,24	4	SCM790-1200Z04R-F0024HB-HP921	30656938
14,00	14	13,8	83	26	36	0,28	4	SCM790-1400Z04R-F0028HB-HP921	30656939
16,00	16	15,8	92	36	42	0,32	4	SCM790-1600Z04R-F0032HB-HP921	30656940
20,00	20	19,8	104	41	53	0,40	4	SCM790-2000Z04R-F0040HB-HP921	30656942

Available on request

18,00	18	17,8	92	36	42	0,36	4	SCM790-1800Z04R-F0036HB-HP921	30656941
-------	----	------	----	----	----	------	---	-------------------------------	----------

Configurable features

Shank form:
Shank form: HA

Specification:
SCM790-0300Z04R-F006[shank form]-HP921

Example:

SCM790-0300Z04R-F006HA-HP921

Shank form HA

Dimensions in mm.

* Design without neck.

For cutting data recommendations, see end of chapter.

Special designs and other coatings available upon request.

OptiMill®-Hardened

Shoulder milling cutter, long design with neck
SCM102

Design:

Diameter of milling cutter: 4.00 - 20.00 mm
Cutting material: HP810
Number of cutting edges: 4
Helix angle: 42°

Application:

For roughing of parts with a hardness of 45 HRC.

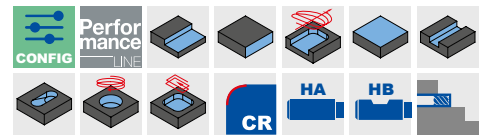
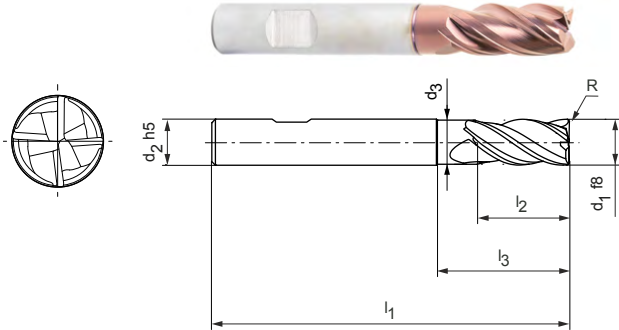

Preferred series in stock

Dimensions							z	Specification	Order no.
d1 f8	d2 h5	d3	l1	l2	l3	R			
4,00	6	-	57	11	-	0,5	4	SCM102-0400Z04R-R0050HB-HP810	31152701
4,00	6	-	57	11	-	1	4	SCM102-0400Z04R-R0100HB-HP810	31152702
6,00	6	5,8	57	13	20	0,5	4	SCM102-0600Z04R-R0050HB-HP810	31152705
6,00	6	5,8	57	13	20	1	4	SCM102-0600Z04R-R0100HB-HP810	31152706
6,00	6	5,8	57	13	20	2	4	SCM102-0600Z04R-R0200HB-HP810	31152708
8,00	8	7,8	63	21	25	0,5	4	SCM102-0800Z04R-R0050HB-HP810	31152709
8,00	8	7,8	63	21	25	1	4	SCM102-0800Z04R-R0100HB-HP810	31152710
8,00	8	7,8	63	21	25	2	4	SCM102-0800Z04R-R0200HB-HP810	31152712
10,00	10	9,8	72	22	30	0,5	4	SCM102-1000Z04R-R0050HB-HP810	31152715
10,00	10	9,8	72	22	30	1	4	SCM102-1000Z04R-R0100HB-HP810	31152716
10,00	10	9,8	72	22	30	2	4	SCM102-1000Z04R-R0200HB-HP810	31152718
12,00	12	11,8	83	26	36	0,5	4	SCM102-1200Z04R-R0050HB-HP810	31152721
12,00	12	11,8	83	26	36	1	4	SCM102-1200Z04R-R0100HB-HP810	31152722
12,00	12	11,8	83	26	36	2	4	SCM102-1200Z04R-R0200HB-HP810	31152724
16,00	16	15,8	92	36	42	0,5	4	SCM102-1600Z04R-R0050HB-HP810	31152728
16,00	16	15,8	92	36	42	1	4	SCM102-1600Z04R-R0100HB-HP810	31152729
16,00	16	15,8	92	36	42	2	4	SCM102-1600Z04R-R0200HB-HP810	31152730
20,00	20	19,8	104	41	55	1	4	SCM102-2000Z04R-R0100HB-HP810	31152734
20,00	20	19,8	104	41	55	2	4	SCM102-2000Z04R-R0200HB-HP810	31152735

Configurable features

Shank form:
Shank form: HA

Specification:
SCM102-0400Z04R-R0050[shank form]-HP810

Example:

SCM102-0400Z04R-R0050HA-HP810

Shank form HA

Dimensions in mm.

For cutting data recommendations, see end of chapter.

Special designs and other coatings available upon request.

OptiMill®-Hardened

Shoulder milling cutter, overlong design with neck
SCM103

Design:

Diameter of milling cutter: 4.00 - 20.00 mm
Cutting material: HP810
Number of cutting edges: 4
Helix angle: 42°

Application:

For roughing of parts with a hardness of 45 HRC.

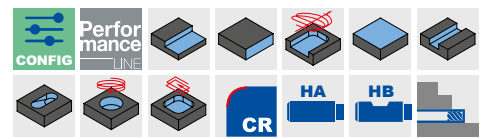
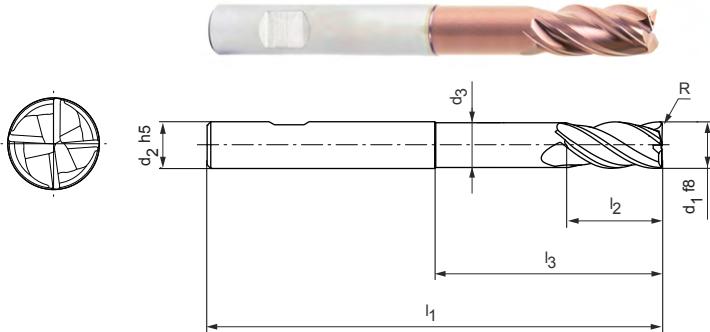

Preferred series in stock

Dimensions							z	Specification	Order no.
d ₁ f8	d ₂ h5	d ₃	l ₁	l ₂	l ₃	R			
4,00	6	3,8	62	11	22	0,5	4	SCM103-0400Z04R-R0050HB-HP810	31152738
4,00	6	3,8	62	11	22	1	4	SCM103-0400Z04R-R0100HB-HP810	31152739
6,00	6	5,8	62	13	25	0,5	4	SCM103-0600Z04R-R0050HB-HP810	31152742
6,00	6	5,8	62	13	25	1	4	SCM103-0600Z04R-R0100HB-HP810	31152743
6,00	6	5,8	62	13	25	2	4	SCM103-0600Z04R-R0200HB-HP810	31152744
8,00	8	7,7	68	21	30	1	4	SCM103-0800Z04R-R0100HB-HP810	31152745
8,00	8	7,7	68	21	30	2	4	SCM103-0800Z04R-R0200HB-HP810	31152746
10,00	10	9,7	80	22	38	0,5	4	SCM103-1000Z04R-R0050HB-HP810	31152747
10,00	10	9,7	80	22	38	1	4	SCM103-1000Z04R-R0100HB-HP810	31152748
10,00	10	9,7	80	22	38	2	4	SCM103-1000Z04R-R0200HB-HP810	31152750
12,00	12	11,6	93	26	46	0,5	4	SCM103-1200Z04R-R0050HB-HP810	31152752
12,00	12	11,6	93	26	46	1	4	SCM103-1200Z04R-R0100HB-HP810	31152753
12,00	12	11,6	93	26	46	2	4	SCM103-1200Z04R-R0200HB-HP810	31152755
16,00	16	15,5	108	36	58	0,5	4	SCM103-1600Z04R-R0050HB-HP810	31152757
16,00	16	15,5	108	36	58	1	4	SCM103-1600Z04R-R0100HB-HP810	31152758
16,00	16	15,5	108	36	58	2	4	SCM103-1600Z04R-R0200HB-HP810	31152759
20,00	20	19,5	126	41	74	1	4	SCM103-2000Z04R-R0100HB-HP810	31152761
20,00	20	19,5	126	41	74	2	4	SCM103-2000Z04R-R0200HB-HP810	31152762

Configurable features

Shank form:
Shank form: HA

Specification:
SCM103-0400Z04R-R0050[shank form]-HP810

Example:

SCM103-0400Z04R-R0050**HA**-HP810

Shank form HA

Dimensions in mm.

For cutting data recommendations, see end of chapter.

Special designs and other coatings available upon request.

OptiMill®-Inox-HPC

Shoulder milling cutter, long design with neck
SCM108

Design:

Diameter of milling cutter: 3.00 – 20.00 mm
Cutting material: HP921
Number of cutting edges: 4
Helix angle: 38°
Special features: Unequal spacing

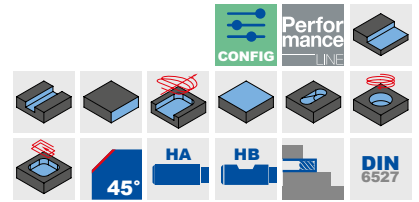
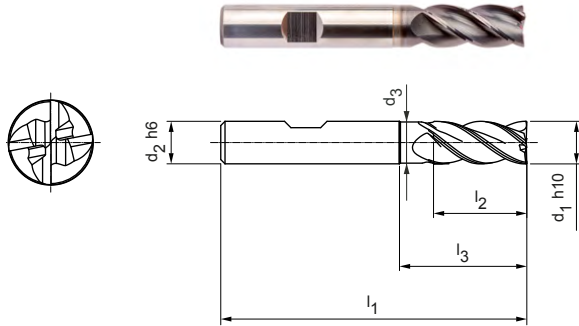

Preferred series in stock

Dimensions							z	Specification	Order no.
d ₁ h10	d ₂ h6	d ₃	l ₁	l ₂	l ₃	Cx45°			
3,00	6	-	57	8	-	0,06	4	SCM108-0300Z04R-F0006HB-HP921	31181468
4,00	6	-	57	11	-	0,08	4	SCM108-0400Z04R-F0008HB-HP921	31181469
5,00	6	-	57	13	-	0,10	4	SCM108-0500Z04R-F0010HB-HP921	31181480
6,00	6	5,8	57	13	19	0,12	4	SCM108-0600Z04R-F0012HB-HP921	31181481
8,00	8	7,8	63	19	25	0,16	4	SCM108-0800Z04R-F0016HB-HP921	31181482
10,00	10	9,8	72	22	30	0,20	4	SCM108-1000Z04R-F0020HB-HP921	31181483
12,00	12	11,8	83	26	36	0,24	4	SCM108-1200Z04R-F0024HB-HP921	31181484
16,00	16	15,8	92	32	42	0,32	4	SCM108-1600Z04R-F0032HB-HP921	31181486
20,00	20	19,8	104	38	52	0,40	4	SCM108-2000Z04R-F0040HB-HP921	31181488

Available on request

14,00	14	13,8	83	26	36	0,28	4	SCM108-1400Z04R-F0028HB-HP921	31181485
18,00	18	17,8	92	32	42	0,36	4	SCM108-1800Z04R-F0036HB-HP921	31181487

Configurable features



Shank form:
Shank form: HA



Specification:
SCM108-0300Z04R-F0006[shank form]-HP921

Example:

SCM108-0300Z04R-F0006HA-HP921

Shank form HA

Dimensions in mm.

For cutting data recommendations, see end of chapter.

Special designs and other coatings available upon request.

OptiMill®-Alu-HPC

Shoulder milling cutter, long design with neck
SCM270

Design:

Diameter of milling cutter: 3.00 – 20.00 mm
Cutting material: HU210
Number of cutting edges: 3
Helix angle: 42°–43°
Special features: Unequal spacing, grooves polished

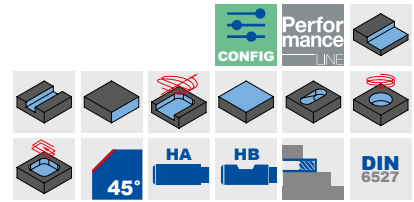
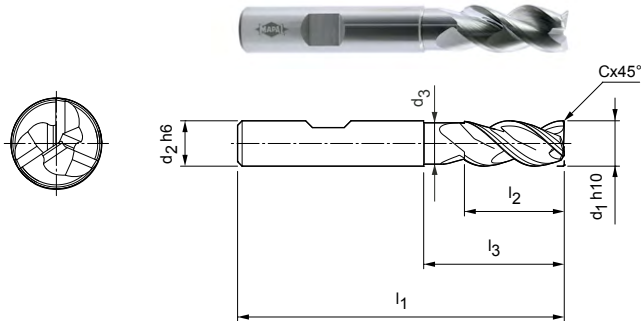

Preferred series in stock

Dimensions							z	Specification	Order no.
d ₁ h ₁₀	d ₂ h ₆	d ₃	l ₁	l ₂	l ₃	Cx45°			
3,00*	6	–	57	7	–	0,06	3	SCM270-0300Z03R-F0006HB-HU210	30393590
4,00*	6	–	57	8	–	0,08	3	SCM270-0400Z03R-F0008HB-HU210	30393591
5,00*	6	–	57	10	–	0,10	3	SCM270-0500Z03R-F0010HB-HU210	30393592
6,00	6	5,5	57	10	18	0,12	3	SCM270-0600Z03R-F0012HB-HU210	30393593
8,00	8	7,5	63	16	25	0,16	3	SCM270-0800Z03R-F0016HB-HU210	30393594
10,00	10	9	72	19	30	0,20	3	SCM270-1000Z03R-F0020HB-HU210	30393595
12,00	12	11	83	22	36	0,24	3	SCM270-1200Z03R-F0024HB-HU210	30393596
16,00	16	15	92	26	42	0,32	3	SCM270-1600Z03R-F0032HB-HU210	30393597
20,00	20	19	104	32	52	0,40	3	SCM270-2000Z03R-F0040HB-HU210	30393598

Available on request

14,00	14	13	83	22	36	0,28	3	SCM270-1400Z03R-F0028HB-HU210	30456715
-------	----	----	----	----	----	------	---	-------------------------------	----------

Configurable features



Shank form:
Shank form: HA



Specification:
SCM270-0300Z03R-F0006[shank form]-HU210

Example:

SCM270-0300Z03R-F0006HA-HU210

Shank form HA

Dimensions in mm.

* Design without neck.

For cutting data recommendations, see end of chapter.

Special designs and other coatings available upon request.

OptiMill®-Alu-HPC-Pocket

Shoulder milling cutter, long design with neck
SCM850

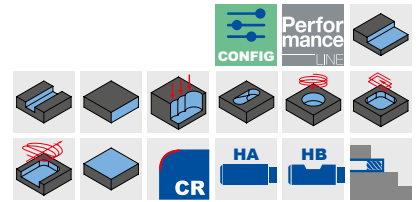
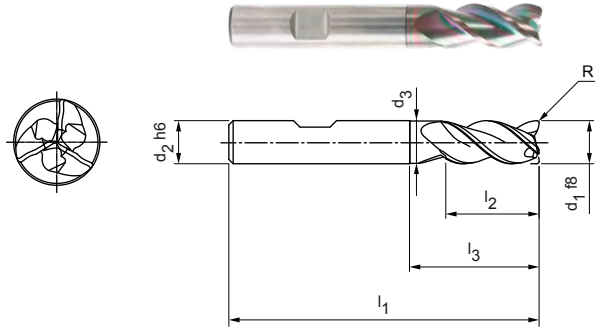

Design:
 Diameter of milling cutter: 5.00 - 20.00 mm
 Cutting material: HP913
 Number of cutting edges: 3
 Helix angle: 42°
 Special features: Face geometry with integrated drill tip

Application:
 Perfect for inclined plunging up to 45°, in helix milling and grooving.

Preferred series in stock

Dimensions							z	Specification	Order no.
d ₁ f8	d ₂ h6	d ₃	l ₁	l ₂	l ₃	R			
5,00	6	4,8	57	13	-	0,2	3	SCM850-0500Z03R-R0020HB-HP913	31054950
6,00	6	5,8	57	13	19	0,2	3	SCM850-0600Z03R-R0020HB-HP913	31054952
8,00	8	7,8	63	19	25	0,2	3	SCM850-0800Z03R-R0020HB-HP913	31054956
10,00	10	9,8	72	22	30	0,32	3	SCM850-1000Z03R-R0032HB-HP913	31054960
12,00	12	11,8	83	26	36	0,32	3	SCM850-1200Z03R-R0032HB-HP913	31054962
14,00	14	13,8	83	26	36	0,32	3	SCM850-1400Z03R-R0032HB-HP913	31054964
16,00	16	15,8	92	31	42	0,32	3	SCM850-1600Z03R-R0032HB-HP913	31054966
20,00	20	19,8	104	41	52	0,5	3	SCM850-2000Z03R-R0050HB-HP913	31054970

Undersize cutters available on request.

Configurable features

Shank form:
Shank form: HA

Specification:
SCM850-0500Z03R-R0020[shank form]-HP913

Example:
 SCM850-0500Z03R-R0020**HA**-HP913
Shank form HA

Dimensions in mm.
 For cutting data recommendations, see end of chapter.
 Special designs and other coatings available upon request.

OptiMill®-Alu-HPC-Pocket

Shoulder milling cutter, 3xD design with neck, includes chip breaker
SCM854

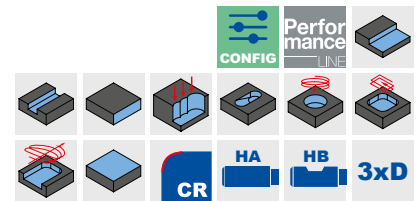
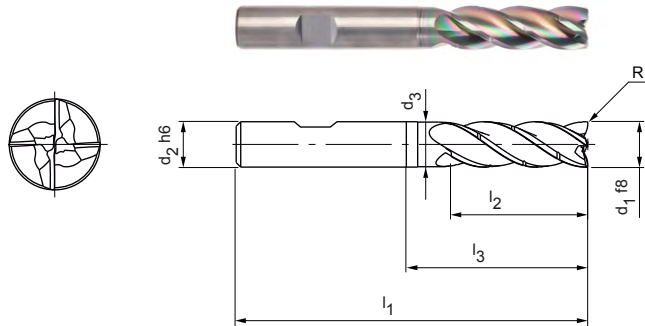

Preferred series in stock

Dimensions							z	Specification	Order no.
d ₁ f8	d ₂ h6	d ₃	l ₁	l ₂	l ₃	R			
5,00	6	4,8	62	17	-	0,20	4	SCM854-0500Z04R-R0020HB-HP913	31302680
6,00	6	5,8	62	18	25	0,20	4	SCM854-0600Z04R-R0020HB-HP913	31302681
8,00	8	7,7	68	24	30	0,20	4	SCM854-0800Z04R-R0020HB-HP913	31302682
10,00	10	9,7	80	30	35	0,32	4	SCM854-1000Z04R-R0032HB-HP913	31302683
12,00	12	11,6	93	36	45	0,32	4	SCM854-1200Z04R-R0032HB-HP913	31302684
14,00	14	13,6	99	42	50	0,32	4	SCM854-1400Z04R-R0032HB-HP913	31302685
16,00	16	15,5	108	48	56	0,32	4	SCM854-1600Z04R-R0032HB-HP913	31302686
20,00	20	19,5	126	60	70	0,50	4	SCM854-2000Z04R-R0050HB-HP913	31302688

Available on request

18,00	18	17,5	117	54	67	0,32	4	SCM854-1800Z04R-R0032HB-HP913	31302687
-------	----	------	-----	----	----	------	---	-------------------------------	----------

Configurable features

Shank form:
Shank form: HA

Specification:
SCM854-0500Z04R-R0020[shank form]-HP913

Example:

SCM854-0500Z04R-R0020HA-HP913

Shank form HA

Dimensions in mm.

For cutting data recommendations, see end of chapter.

Special designs and other coatings available upon request.

OptiMill®-SPM

Shoulder milling cutter with internal cooling
SCM681/691

Design:

Diameter of milling cutter: 12.00 – 32.00 mm
Cutting material: HU610
Number of cutting edges: 3
Helix angle: 43°

Application:

For the machining of aluminium structural parts.

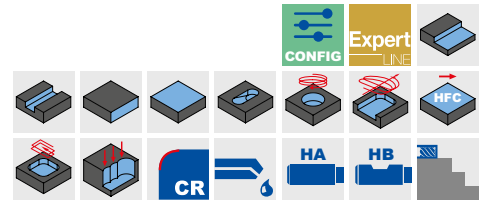
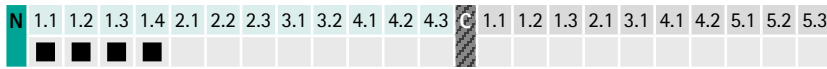
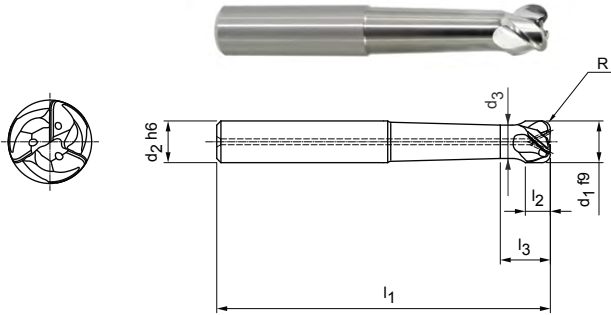

Short design, SCM681 | Preferred series in stock

Dimensions							z	Specification	Order no.
d1 f9	d2 h6	d3	l1	l2	l3	R			
32,00	32	27	125	26,3	40,9	4	3	SCM681-3200Z03R-R0400HA-HU610	30551346

Short design, SCM681 | Available upon request

16,00	16	12,8	81	12,8	28	3	3	SCM691-1600Z03R-R0300HA-HU610	30551341
20,00	20	16	90	16	35	3	3	SCM691-2000Z03R-R0300HA-HU610	30551344

Long design, SCM691 | Preferred series in stock

Dimensions							z	Specification	Order no.
d1 f9	d2 h6	d3	l1	l2	l3	R			
12,00	12	9,6	90	10,3	19,4	2	3	SCM691-1200Z03R-R0200HA-HU610	30551330
16,00	16	12,8	105	13,5	23,8	3	3	SCM691-1600Z03R-R0300HA-HU610	30551350
20,00	20	16	120	16,7	28,2	3	3	SCM691-2000Z03R-R0300HA-HU610	30551352
25,00	25	20	145	20,7	33,7	4	3	SCM691-2500Z03R-R0400HA-HU610	30551353
32,00	32	27	173	26,3	40,2	4	3	SCM691-3200Z03R-R0400HA-HU610	30551354

Long design, SCM691 | Available upon request

14,00	16	11,2	99	11,2	45,5	3	3	SCM691-1400Z03R-R0300HA-HU610	30551348
-------	----	------	----	------	------	---	---	-------------------------------	----------

Configurable features



Shank form:
Shank form: HB



Specification:
SCM681-3200Z03R-R0400[shank form]-HU610

Example:

SCM681-3200Z03R-R0400HB-HU610

Shank form HB

Dimensions in mm.

For cutting data recommendations, see end of chapter.

Special designs and other coatings available upon request.

OptiMill®-Diamond-SPM

Shoulder milling cutter with internal cooling*
SHM101/110

Design:

Diameter of milling cutter: 6.00 – 32.00 mm
Cutting material: PU622
Number of cutting edges: 3
Axis angle: 9/12°
Special features: PCD cutting edges

Application:

For the machining of aluminium structural parts.

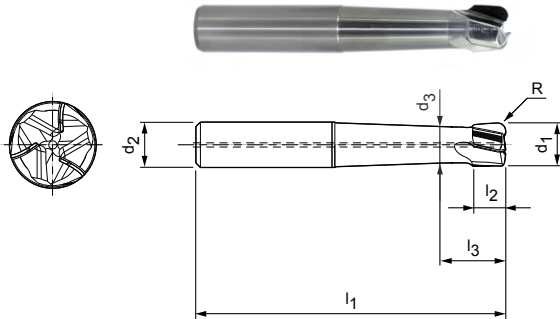

N	1.1	1.2	1.3	1.4	2.1	2.2	2.3	3.1	3.2	4.1	4.2	4.3	C	1.1	1.2	1.3	2.1	3.1	4.1	4.2	5.1	5.2	5.3
---	-----	-----	-----	-----	-----	-----	-----	-----	-----	-----	-----	-----	---	-----	-----	-----	-----	-----	-----	-----	-----	-----	-----

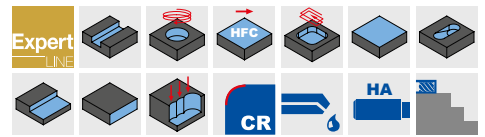

Short design, SHM101 | Preferred series in stock

Dimensions							z	Specification	Order no.
d ₁	d ₂	d ₃	l ₁	l ₂	l ₃	R			
20,00	20	17	90	14,2	22,6	3	3	SHM101-2000CZ03R-R0300HA-PU622	30552846
25,00	25	20	107	17,8	28,2	4	3	SHM101-2500DZ03R-R0400HA-PU622	30552849
32,00	32	27,2	125	20	27,9	4	3	SHM101-3200DZ03R-R0400HA-PU622	30552851

Short design, SHM110, 111 | Available upon request

14,00	16	11,8	77	10	16,6	3	3	SHM101-1400BZ03R-R0300HA-PU622	30552836
15,00	16	12	78	10,6	18,5	3	3	SHM101-1500CZ03R-R0300HA-PU622	30552839
16,00	16	12,8	81	11,4	19,5	3	3	SHM101-1600CZ03R-R0300HA-PU622	30552842
18,00	20	14,4	87	12,8	20,4	3	3	SHM101-1800CZ03R-R0300HA-PU622	30552844

Long design, SHM111 | Preferred series in stock

12,00	12	10,2	90	8,5	15,1	2	3	SHM111-1200BZ03R-R0200HA-PU622	30552834
16,00	16	12,8	105	11,4	19,5	3	3	SHM111-1600CZ03R-R0300HA-PU622	30552843
20,00	20	17	120	14,2	22,6	3	3	SHM111-2000CZ03R-R0300HA-PU622	30552847
25,00	25	20	145	17,8	28,2	4	3	SHM111-2500DZ03R-R0400HA-PU622	30552850
32,00	32	27,2	173	20	27,9	4	3	SHM111-3200DZ03R-R0400HA-PU622	30552852

Long design, SHM111 | Available upon request

6,00	6	5,1	60	6	12,5	1	3	SHM110-0600BZ03R-R0100HA-PU622	30552830
8,00	8	6,4	70	7	13,2	1	3	SHM110-0800BZ03R-R0100HA-PU622	30552832
10,00	10	8,5	80	7,5	13,7	2	3	SHM111-1000BZ03R-R0200HA-PU622	30552833
14,00	16	11,8	99	10	16,6	3	3	SHM111-1400BZ03R-R0300HA-PU622	30552837
15,00	16	12	100	10,6	18,5	3	3	SHM111-1500CZ03R-R0300HA-PU622	30552841
18,00	20	14,4	114	12,8	20,4	3	3	SHM111-1800CZ03R-R0300HA-PU622	30552845

Dimensions in mm.

* Internal cooling from \varnothing 10 mm.

For cutting data recommendations, see end of chapter.

Special designs available upon request.

OptiMill®-Diamond-SPM

Shoulder milling cutter, with HSK-A (hollow shank taper form A) connection, with internal cooling
SHM121

Design:

Diameter of milling cutter: 32.00 – 50.00 mm
Cutting material: PU622
Number of cutting edges: 3/4
Helix angle: 12°
Special features: PCD cutting edges

Application:

For the machining of aluminium structural parts.

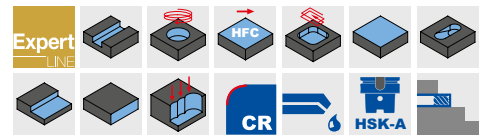
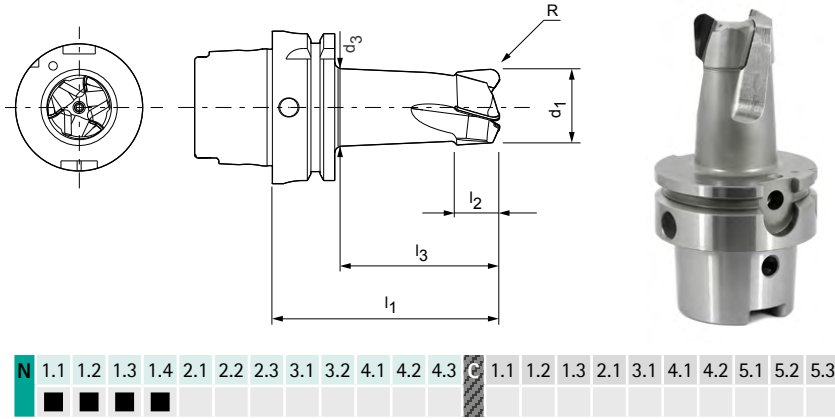

Preferred series in stock

Dimensions						z	Specification	Order no.
d ₁	d ₃	l ₁	l ₂	l ₃	R			
32,00	31,5	86	17	57	4	3	SHM121-3200Z03R-R0400A6-PU622	30583603
40,00	39	98	17	70	4	4	SHM121-4000Z04R-R0400A6-PU622	30597953
50,00	49	109	20	80	4	4	SHM121-5000Z04R-R0400A6-PU622	30590483

Available on request | Design with increased hollow shank taper face connection ø 80 mm

32,00	31,5	86	17	57	4	3	SHM121-3200Z03R-R0400A6-PU622	30625821
50,00	49	109	20	80	4	4	SHM121-5000Z04R-R0400A6-PU622	30625820

Dimensions in mm.

For cutting data recommendations, see end of chapter.

Special designs available upon request.

OptiMill®-Diamond type 50

Shoulder milling cutter, overlong design with neck
SHM500

Design:

Diameter of milling cutter: 4.00 – 5.00 mm
Cutting material: PU611
Number of cutting edges: 1
Axis angle: 0°
Special features: PCD cutting edges

Application:

Designed for delicate milling tasks, e.g. in precision mechanics or for the production of printed circuit boards.

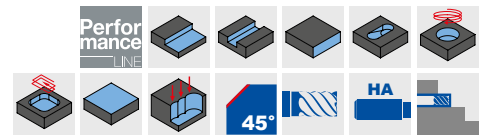
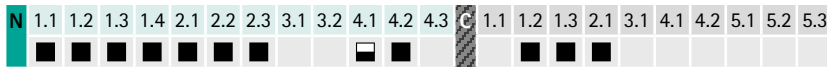
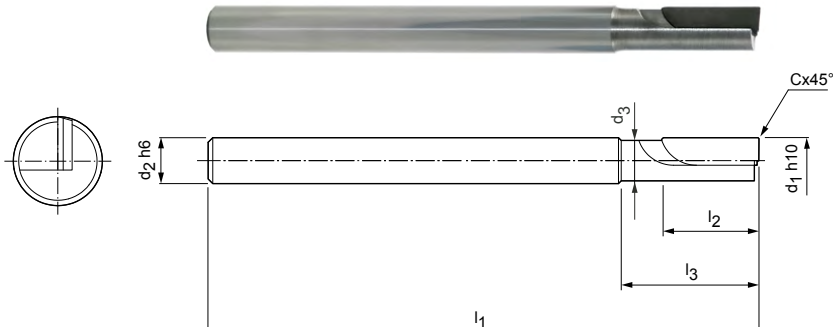

Preferred series in stock

Dimensions							z	Specification	Order no.
d ₁ h10	d ₂ h6	d ₃	l ₁	l ₂	l ₃	Cx45°			
4,00	4	3,6	60	10	15	0,10	1	SHM500-0400BZ01R-F0010HA-PU611	30696677
5,00	5	4,4	60	10	15	0,10	1	SHM500-0500BZ01R-F0010HA-PU611	30696678

Dimensions in mm.
For cutting data recommendations, see end of chapter.
Special designs available upon request.

OptiMill®-Diamond type 51

Shoulder milling cutter, overlong design with neck, includes internal cooling
SHM511 | SHM611 | SHM711

Design:

Diameter of milling cutter: 3.00 - 12.00 mm
Cutting material: PU611
Number of cutting edges: 2
Axis angle: neutral/positive/negative
Special features: PCD cutting edge

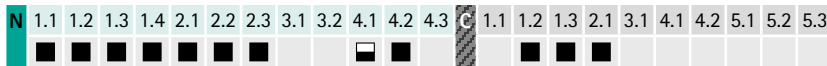
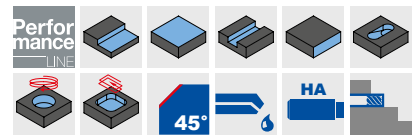
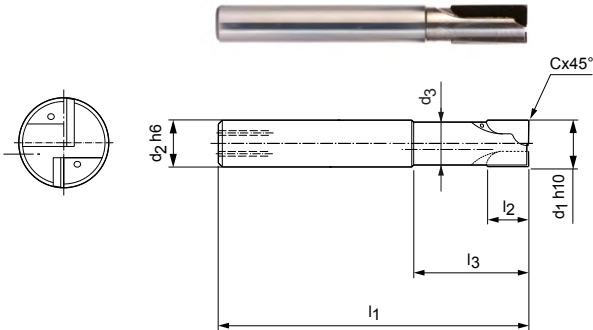

Preferred series in stock

Dimensions							z	Specification	Order no.		
d ₁ h ₁₀	d ₂ h ₆	d ₃	l ₁	l ₂	l ₃	Cx45°			SHM511	SHM611	SHM711
3,00	6	2,8	60	2,5	15	0,10	2	SHM_*1-0300AZ02R-F0010HA-PU611	30334896	30334944	30334931
4,00	6	3,8	60	2,5	15	0,10	2	SHM_*1-0400AZ02R-F0010HA-PU611	30334901	30334956	30334939
5,00	6	4,6	60	3	15	0,10	2	SHM_*1-0500AZ02R-F0010HA-PU611	30334923	30334957	30334942
6,00	6	5,4	60	10	15	0,10	2	SHM_*1-0600BZ02R-F0010HA-PU611	30696680	30696681	30696682
6,00	6	5,4	60	15	20	0,10	2	SHM_*1-0600CZ02R-F0010HA-PU611	30696683	30696684	30696685
8,00	8	7,4	80	10	20	0,10	2	SHM_*1-0800BZ02R-F0010HA-PU611	30696689	30696690	30696691
8,00	8	7,4	80	20	30	0,10	2	SHM_*1-0800DZ02R-F0010HA-PU611	30696695	30696696	30696697
10,00	10	9,4	80	10	30	0,10	2	SHM_*1-1000BZ02R-F0010HA-PU611	30696698	30696699	30696700
10,00	10	9,4	90	20	30	0,10	2	SHM_*1-1000DZ02R-F0010HA-PU611	30290541	30290551	30290546
12,00	12	11	100	10	30	0,10	2	SHM_*1-1200BZ02R-F0010HA-PU611	30696704	30696705	30696706
12,00	12	11	100	20	30	0,10	2	SHM_*1-1200DZ02R-F0010HA-PU611	30696710	30696711	30696712

Cutting edge form

SHM511	SHM611	SHM711
Neutral axis angle	Negative axis angle	Positive axis angle
Straight cutting edge for neutral use.	Pushing cutting edge. The material is pressed onto the base. This is particularly well suited for thin materials.	Pulling cutting edge for normal use.

Dimensions in mm.

* Specification plus desired cutting edge form (see cutting edge form table).

For cutting data recommendations, see end of chapter.

Special designs and CVD-tipped tools available upon request.

OptiMill®-Diamond type 53

Shoulder milling cutter, long design with neck, includes internal cooling
SHM531

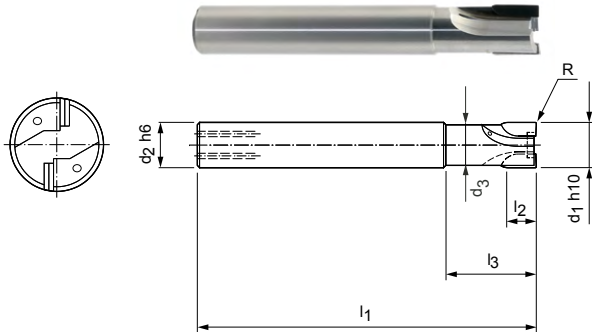

Design:

Diameter of milling cutter: 6.00 – 20.00 mm
Cutting material: PU611
Number of cutting edges: 2 to \varnothing 12 mm
3 from \varnothing 14 mm
Axis angle: $2^\circ/4^\circ/6^\circ$
Special features: No centre cutting edge
PCD cutting edge

Application:

Specially designed for high material removal rates and feeds per tooth. Closed pockets are machined by plunging into the workpiece.

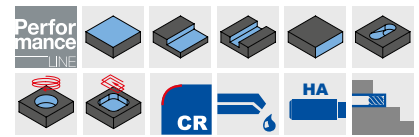

Preferred series in stock

Dimensions							z	Specification	Order no.
d ₁ h10	d ₂ h6	d ₃	l ₁	l ₂	l ₃	R			
6,00	8	5	55	6	15	0,2	2	SHM531-0600AZ02R-R0020HA-PU611	30696717
10,00	10	9	75	6	20	0,2	2	SHM531-1000AZ02R-R0020HA-PU611	30696719
12,00	12	11	85	10	25	0,2	2	SHM531-1200BZ02R-R0020HA-PU611	30696720
14,00	16	13	85	10	25	0,2	3	SHM531-1400BZ03R-R0020HA-PU611	30696721
16,00	16	15	85	10	25	0,2	3	SHM531-1600BZ03R-R0020HA-PU611	30696722
20,00	20	19	100	10	50	0,2	3	SHM531-2000BZ03R-R0020HA-PU611	30696723

Available on request

8,00	8	7,2	60	6	20	0,2	2	SHM531-0800AZ02R-R0020HA-PU611	30696718
------	---	-----	----	---	----	-----	---	--------------------------------	----------

Dimensions in mm.

For cutting data recommendations, see end of chapter.

Special designs available upon request.

OptiMill®-Diamond type 57

Shoulder milling cutter, long design with neck, includes internal cooling
SHM571

Design:

Diameter of milling cutter: 16.00 – 25.00 mm
Cutting material: PU611
Number of cutting edges: 3
Helix angle: 15°
Special features: No centre cutting edge
PCD cutting edge

Application:

The spirally designed cutting rows are ideally suited for high volume machining, e.g. for integral components.

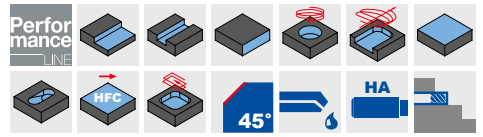
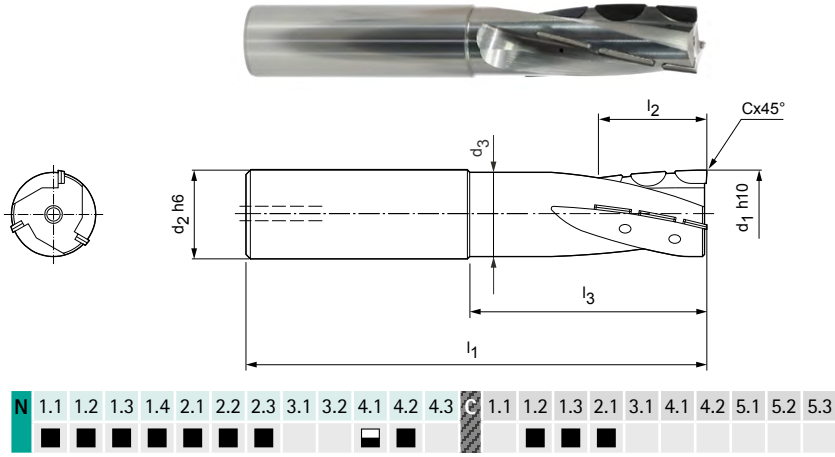

Preferred series in stock

Dimensions							z	Specification	Order no.
d ₁ h ₁₀	d ₂ h ₆	d ₃	l ₁	l ₂	l ₃	Cx45°			
16,00	16	15	100	30	49	0,10	3	SHM571-1600FZ03R-F0010HA-PU611	30696731
20,00	20	19	100	30	49	0,10	3	SHM571-2000FZ03R-F0010HA-PU611	30696732
25,00	25	24	110	30	49	0,10	3	SHM571-2500FZ03R-F0010HA-PU611	30696733

Dimensions in mm.
For cutting data recommendations, see end of chapter.
Special designs available upon request.

OptiMill®-Diamond type 57

Shoulder milling cutter, with HSK-A (hollow shank taper form A) connection, with internal cooling
SHM571

Design:

Diameter of milling cutter: 32.00 – 63.00 mm
Cutting material: PU611
Number of cutting edges: 3 to \varnothing 40 mm
4 from \varnothing 50 mm
Helix angle: 15°
Special features: No centre cutting edge
PCD cutting edge

Application:

The spirally designed cutting rows are ideally suited for high volume machining.

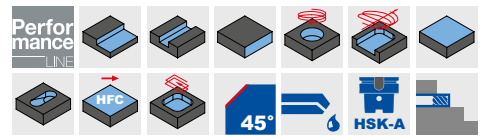
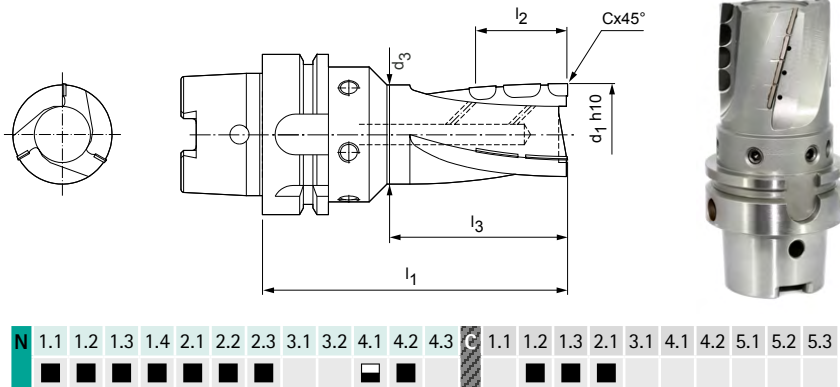

Preferred series in stock

Dimensions						z	Specification	Order no.
d ₁ h10	d ₃	l ₁	l ₂	l ₃	Cx45°			
32,00	31	100	30	50	0,10	3	SHM571-3200FZ03R-F0010A6-PU611	30696736
40,00	39	100	40	53	0,10	3	SHM571-4000HZ03R-F0010A6-PU611	30696739
50,00	49	100	40	56	0,10	4	SHM571-5000HZ04R-F0010A6-PU611	30696742

Available on request

63,00	62	100	40	73	0,10	4	SHM571-6300HZ04R-F0010A6-PU611	30696745
-------	----	-----	----	----	------	---	--------------------------------	----------

Design with shank form SK40 or BT40 available upon request.

Dimensions in mm.

For cutting data recommendations, see end of chapter.

Special designs available upon request.

OptiMill®-Mono-Alu

Shoulder milling cutter, design with pulling/pushing cutting edge
SCM280

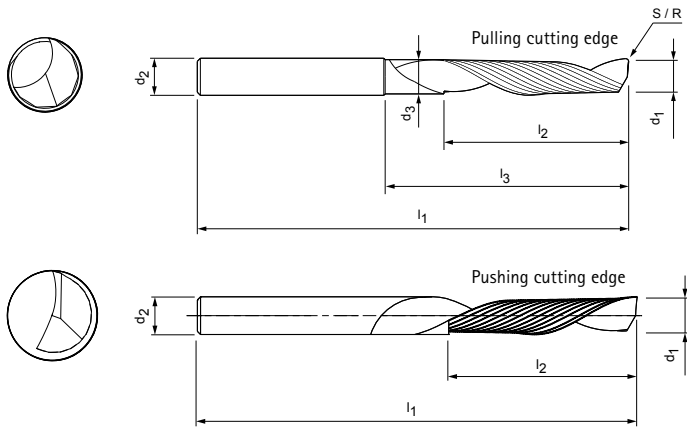

Design:

- Diameter of milling cutter: 2.00 - 10.00 mm
- Cutting material: HU211
- Number of cutting edges: 1
- Helix angle: 30°
- Special features: Large chip space for unhindered chip discharge

N	1.1	1.2	1.3	1.4	2.1	2.2	2.3	3.1	3.2	4.1	4.2	4.3	C	1.1	1.2	1.3	2.1	3.1	4.1	4.2	5.1	5.2	5.3	
	■	■	■	■	■	■	■			■	■	■	■											

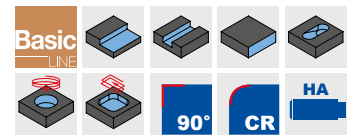

Preferred series in stock

Dimensions							z	Specification	Order no.
d ₁	d ₂	d ₃	l ₁	l ₂	l ₃	R			
2,00	3	-	38	5	-	-	1	SCM280-0200Z01R-S-HA-HU211	30393706
3,00	3	-	38	8	-	-	1	SCM280-0300Z01R-S-HA-HU211	30393708
3,00	4	-	38	8	-	-	1	SCM280-0300Z01R-S-HA-HU211	30393709
4,00	4	-	40	12	-	-	1	SCM280-0400Z01R-S-HA-HU211	30393713
4,00	4	-	70	30	-	-	1	SCM280-0400Z01R-S-HA-HU211	30393714
4,00	6	-	50	10	-	-	1	SCM280-0400Z01R-S-HA-HU211	30393715
4,00	6	-	50	10	-	-	1	SCM280-0400Z01L-S-HA-HU211	30393738
5,00	5	-	60	15	-	-	1	SCM280-0500Z01R-S-HA-HU211	30393718
5,00	6	-	50	12	-	-	1	SCM280-0500Z01R-S-HA-HU211	30393720
6,00	6	-	50	12	-	-	1	SCM280-0600Z01R-S-HA-HU211	30393725
6,00	6	-	60	15	-	-	1	SCM280-0600Z01L-S-HA-HU211	30393742
6,00	6	-	60	20	-	-	1	SCM280-0600Z01R-S-HA-HU211	30393721
6,00	6	-	70	15	-	-	1	SCM280-0600Z01R-S-HA-HU211	30393724
6,00	6	-	70	30	-	-	1	SCM280-0600Z01R-S-HA-HU211	30393722
6,00	6	-	80	38	-	-	1	SCM280-0600Z01R-S-HA-HU211	30393723
6,00	8	5,6	80	20	35	1,50	1	SCM280-0600Z01R-R0150HA-HU211	30393756
8,00	8	-	60	22	-	-	1	SCM280-0800Z01R-S-HA-HU211	30393727
8,00	8	-	80	38	-	-	1	SCM280-0800Z01R-S-HA-HU211	30393728
10,00	10	-	60	25	-	-	1	SCM280-1000Z01R-S-HA-HU211	30393730
10,00	10	-	75	30	-	-	1	SCM280-1000Z01R-S-HA-HU211	30393729

Example:
SCM280-0400Z01R-S-HA-HU211

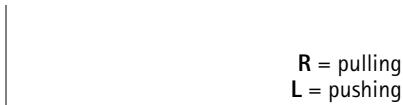

Dimensions in mm.
For cutting data recommendations, see end of chapter.
Special designs and other coatings available upon request.

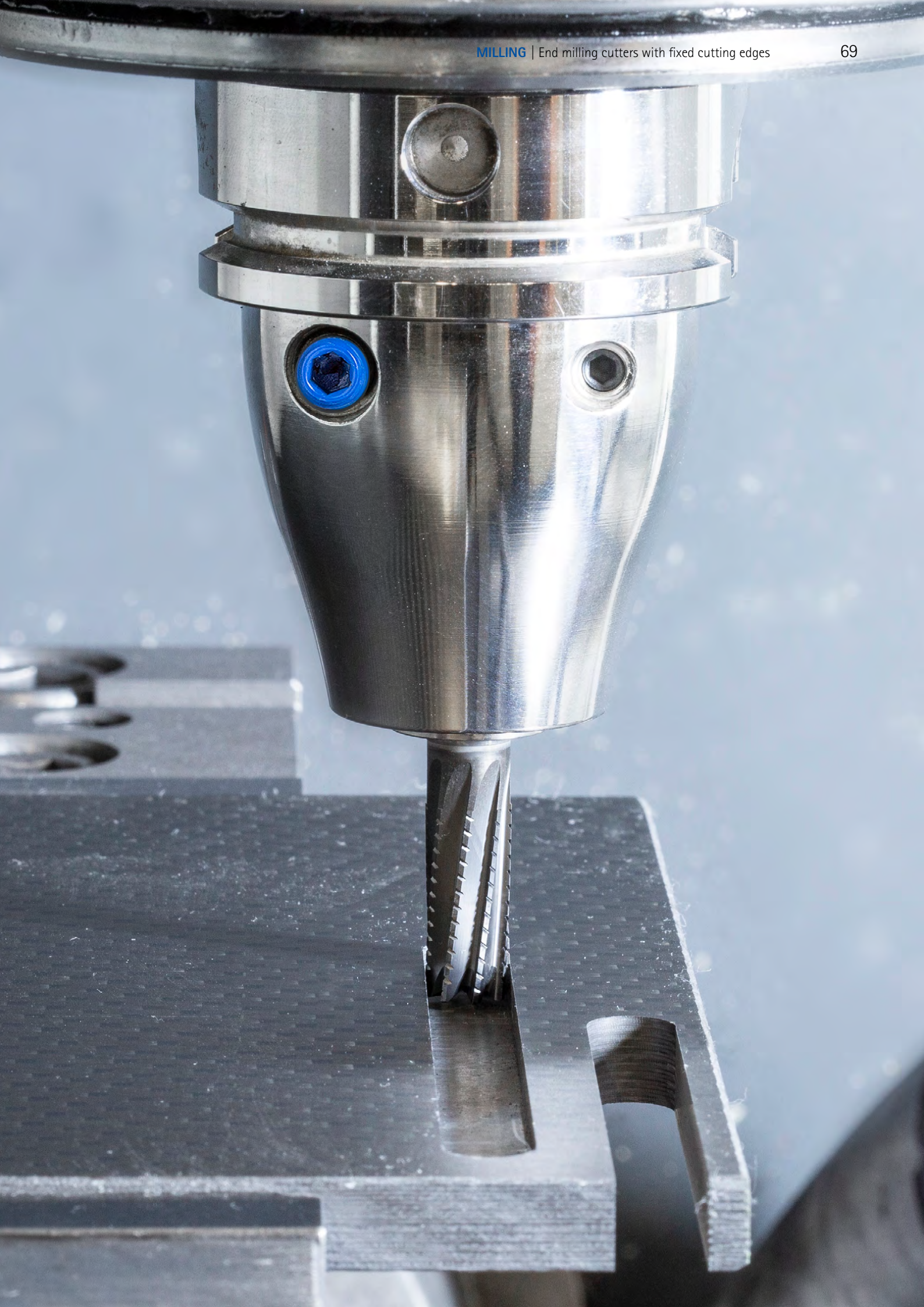

OptiMill®-Composite-Speed-Plus

Shoulder milling cutter, design with pulling cutting edge
SCM982

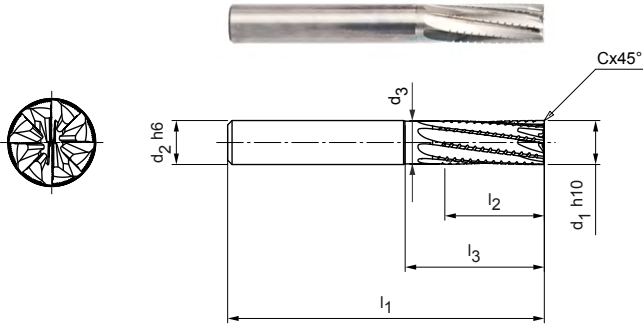

N	1.1	1.2	1.3	1.4	2.1	2.2	2.3	3.1	3.2	4.1	4.2	4.3	C	1.1	1.2	1.3	2.1	3.1	4.1	4.2	5.1	5.2	5.3	

Design:
 Diameter of milling cutter: 4.00 - 20.00 mm
 Cutting material: HU610
 Number of cutting edges: 8
 Helix angle: 8°
 Special features: Without coating, extremely sharp cutting edge

Application:
 Roughing and finishing of CFRP in one machining step. Pulling cutting edge for better removal of the chips/dust (e.g. on milling pockets and slots). Particularly suitable for difficult to machine surface layers (e.g. UD or copper mesh) to prevent delamination on the lower edge of the part.

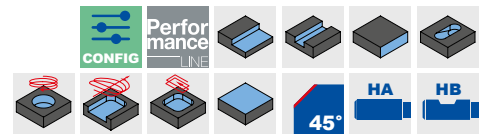

Preferred series in stock

Dimensions							z	Specification	Order no.
d1 h10	d2 h6	d3	l1	l2	l3	Cx45°			
4,00	6	3,90	57	11	-	0,08	8	SCM982-0400Z08R-F0008HA-HU610	31237353
5,00	6	4,90	57	13	-	0,10	8	SCM982-0500Z08R-F0010HA-HU610	31237354
6,00	6	5,80	57	13	19	0,12	8	SCM982-0600Z08R-F0012HA-HU610	31237355
6,00	6	5,80	65	21	27	0,12	8	SCM982-0600Z08R-F0012HA-HU610	31237356
8,00	8	7,80	63	19	25	0,16	8	SCM982-0800Z08R-F0016HA-HU610	31237357
8,00	8	7,80	70	22	32	0,16	8	SCM982-0800Z08R-F0016HA-HU610	31237358
10,00	10	9,70	72	22	30	0,20	8	SCM982-1000Z08R-F0020HA-HU610	31237359
12,00	12	11,60	83	26	36	0,24	8	SCM982-1200Z08R-F0024HA-HU610	31237380
16,00	16	15,50	92	32	42	0,32	8	SCM982-1600Z08R-F0032HA-HU610	31237381

Available on request

20,00	20	19,40	104	38	52	0,40	8	SCM982-2000Z08R-F0040HA-HU610	31237382
-------	----	-------	-----	----	----	------	---	-------------------------------	----------

Configurable features



Shank form:
Shank form: HB



Specification:
SCM982-0400Z08R-F0008[shank form]-HU610

Example:
SCM982-0400Z08R-F0008HB-HU610

Shank form HB

Dimensions in mm.
 For cutting data recommendations, see end of chapter.
 Special designs and other coatings available upon request.

OptiMill®-Composite-Speed-Plus

Shoulder milling cutter, design with pushing cutting edge
SCM992

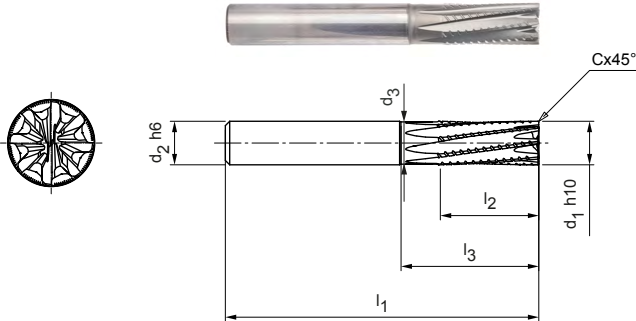

N	1.1	1.2	1.3	1.4	2.1	2.2	2.3	3.1	3.2	4.1	4.2	4.3	C	1.1	1.2	1.3	2.1	3.1	4.1	4.2	5.1	5.2	5.3
---	-----	-----	-----	-----	-----	-----	-----	-----	-----	-----	-----	-----	---	-----	-----	-----	-----	-----	-----	-----	-----	-----	-----

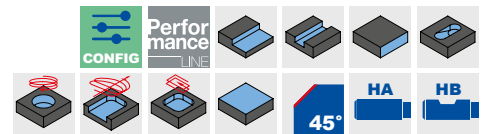

Design:
 Diameter of milling cutter: 4.00 - 20.00 mm
 Cutting material: HU610
 Number of cutting edges: 8
 Helix angle: -8 °
 Special features: Without coating, extremely sharp cutting edge

Application:
 Roughing and finishing of CFRP in one machining step. Pushing cutting edge, where the material is pressed onto the base (e.g. very suitable for vacuum clamping). Particularly suitable for difficult to machine surface layers (e.g. UD or copper mesh) to prevent delamination on the upper edge of the part.

Preferred series in stock

Dimensions							z	Specification	Order no.
d1 h10	d2 h6	d3	l1	l2	l3	Cx45°			
4,00	6	3,90	57	11	-	0,08	8	SCM992-0400Z08R-F0008HA-HU610	31242585
5,00	6	4,90	57	13	-	0,10	8	SCM992-0500Z08R-F0010HA-HU610	31242586
6,00	6	5,80	57	13	19	0,12	8	SCM992-0600Z08R-F0012HA-HU610	31242587
6,00	6	5,80	65	21	27	0,12	8	SCM992-0600Z08R-F0012HA-HU610	31242588
8,00	8	7,80	63	19	25	0,16	8	SCM992-0800Z08R-F0016HA-HU610	31242589
8,00	8	7,80	70	22	32	0,16	8	SCM992-0800Z08R-F0016HA-HU610	31242590
10,00	10	9,70	72	22	30	0,20	8	SCM992-1000Z08R-F0020HA-HU610	31242591
12,00	12	11,60	83	26	36	0,24	8	SCM992-1200Z08R-F0024HA-HU610	31242592
16,00	16	15,50	92	32	42	0,32	8	SCM992-1600Z08R-F0032HA-HU610	31242593

Available on request

20,00	20	19,40	104	38	52	0,40	8	SCM992-2000Z08R-F0040HA-HU610	31242594
-------	----	-------	-----	----	----	------	---	-------------------------------	----------

Configurable features



Shank form:
Shank form: HB



Specification:
SCM992-0400Z08R-F0008[shank form]-HU610

Example:
SCM992-0400Z08R-F0008HB-HU610

Shank form HB

Dimensions in mm.
 For cutting data recommendations, see end of chapter.
 Special designs and other coatings available upon request.

OptiMill®-Composite-Speed-Plus

Shoulder milling cutter, design with pulling cutting edge
SCM980, follow-up product of SCM460

Design:

Diameter of milling cutter: 4.00 - 20.00 mm
Cutting material: HC633
Number of cutting edges: 8
Helix angle: 8°
Special features: Diamond coating

Application:

Roughing and finishing of CFRP in one machining step. Pulling cutting edge for better removal of the chips/dust (e.g. on milling pockets and slots). Particularly suitable for difficult to machine surface layers (e.g. UD or copper mesh) to prevent delamination on the lower edge of the part.

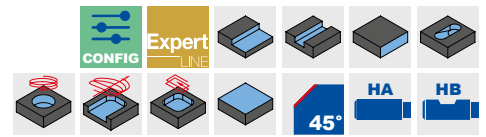
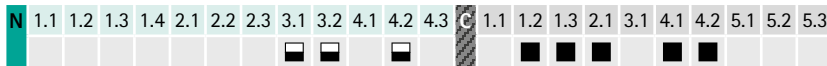
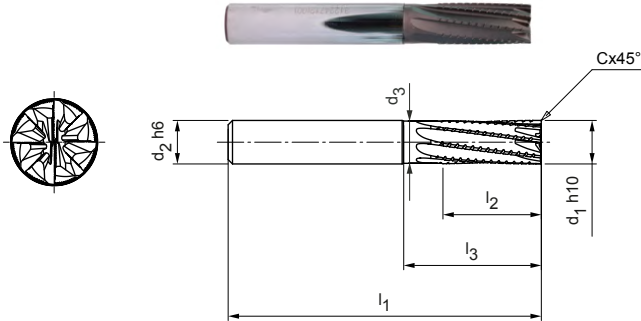

Preferred series in stock

Dimensions							z	Specification	Order no.
d ₁ h10	d ₂ h6	d ₃	l ₁	l ₂	l ₃	Cx45°			
4,00	6	3,90	57	11	-	0,08	8	SCM980-0400Z08R-F0008HA-HC633	31223245
5,00	6	4,90	57	13	-	0,10	8	SCM980-0500Z08R-F0010HA-HC633	31223246
6,00	6	5,80	57	13	19	0,12	8	SCM980-0600Z08R-F0012HA-HC633	31223247
6,00	6	5,80	65	21	27	0,12	8	SCM980-0600Z08R-F0012HA-HC633	31223248
8,00	8	7,80	63	19	25	0,16	8	SCM980-0800Z08R-F0016HA-HC633	31223249
8,00	8	7,80	70	22	32	0,16	8	SCM980-0800Z08R-F0016HA-HC633	31223260
10,00	10	9,70	72	22	30	0,20	8	SCM980-1000Z08R-F0020HA-HC633	31223261
12,00	12	11,60	83	26	36	0,24	8	SCM980-1200Z08R-F0024HA-HC633	31223262
16,00	16	15,50	92	32	42	0,32	8	SCM980-1600Z08R-F0032HA-HC633	31223263

Available on request

20,00	20	19,40	104	38	52	0,40	8	SCM980-2000Z08R-F0040HA-HC633	31223264
-------	----	-------	-----	----	----	------	---	-------------------------------	----------

Configurable features



Shank form:
Shank form: HB



Specification:
SCM980-0400Z08R-F0008[shank form]-HC633

Example:

SCM980-0400Z08R-F0008HB-HC633

Shank form HB

Dimensions in mm.

For cutting data recommendations, see end of chapter.

Special designs and other coatings available upon request.

OptiMill®-Composite-Speed-Plus

Shoulder milling cutter, design with pushing cutting edge
SCM990, follow-up product of SCM470

Design:

Diameter of milling cutter: 4.00 - 20.00 mm
Cutting material: HC633
Number of cutting edges: 8
Helix angle: -8 °
Special features: Diamond coating

Application:

Roughing and finishing of CFRP in one machining step. Pushing cutting edge, where the material is pressed onto the base (e.g. very suitable for vacuum clamping). Particularly suitable for difficult to machine surface layers (e.g. UD or copper mesh) to prevent delamination on the upper edge of the part.

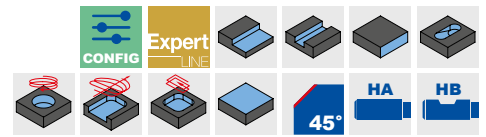
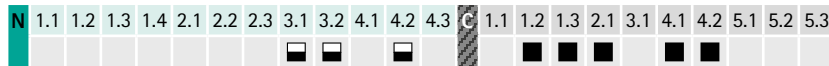
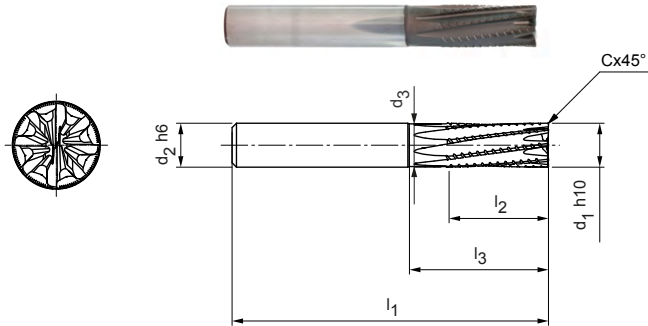

Preferred series in stock

Dimensions							z	Specification	Order no.
d ₁ h10	d ₂ h6	d ₃	l ₁	l ₂	l ₃	Cx45°			
4,00	6	3,90	57	11	-	0,08	8	SCM990-0400Z08R-F0008HA-HC633	31223265
5,00	6	4,90	57	13	-	0,10	8	SCM990-0500Z08R-F0010HA-HC633	31223266
6,00	6	5,80	57	13	19	0,12	8	SCM990-0600Z08R-F0012HA-HC633	31223267
6,00	6	5,80	65	21	27	0,12	8	SCM990-0600Z08R-F0012HA-HC633	31223268
8,00	8	7,80	63	19	25	0,16	8	SCM990-0800Z08R-F0016HA-HC633	31223269
8,00	8	7,80	70	22	32	0,16	8	SCM990-0800Z08R-F0016HA-HC633	31223270
10,00	10	9,70	72	22	30	0,20	8	SCM990-1000Z08R-F0020HA-HC633	31223271
12,00	12	11,60	83	26	36	0,24	8	SCM990-1200Z08R-F0024HA-HC633	31223272
16,00	16	15,50	92	32	42	0,32	8	SCM990-1600Z08R-F0032HA-HC633	31223273

Available on request

20,00	20	19,40	104	38	52	0,40	8	SCM990-2000Z08R-F0040HA-HC633	31223274
-------	----	-------	-----	----	----	------	---	-------------------------------	----------

Configurable features

Shank form:
Shank form: HB

Specification:
SCM990-0400Z08R-F0008[shank form]-HC633

Example:

SCM990-0400Z08R-F0008HB-HC633

Shank form HB

Dimensions in mm.

For cutting data recommendations, see end of chapter.

Special designs and other coatings available upon request.

OptiMill®-Composite-Micro

Shoulder milling cutter, short design, pulling cutting edge
SCM560

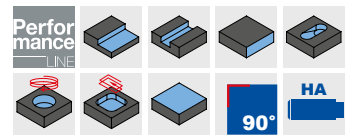
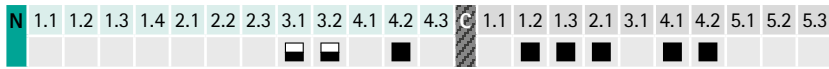
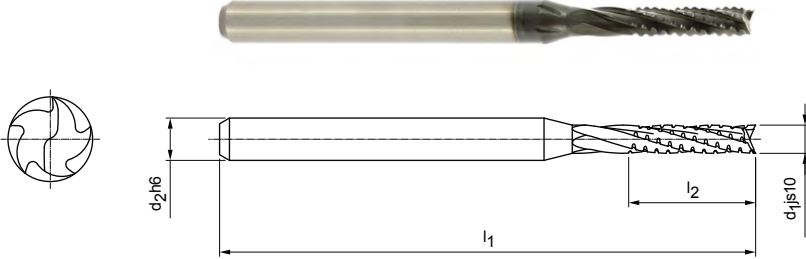

Design:

Diameter of milling cutter: 1.00 – 3.00 mm
Cutting material: HC620
Number of cutting edges: Multi-tooth
Special features: Diamond coating

Application:

Pulling cutting edge for better removal of the chips/dust (e.g. on milling pockets and slots). Particularly suitable for difficult to machine surface layers (e.g. UD or copper mesh) to prevent delamination on the lower edge of the part.

Preferred series in stock

Dimensions				z	Specification	Order no.
d ₁ js10	d ₂ h6	l ₁	l ₂			
1,00	3	38	5	Multi-tooth	SCM560-0100ZMVR-S-HA-HC620	30504698
2,00	3	38	9	Multi-tooth	SCM560-0200ZMVR-S-HA-HC620	30504700
3,00	3	38	9	Multi-tooth	SCM560-0300ZMVR-S-HA-HC620	30504702

Dimensions in mm.

For cutting data recommendations, see end of chapter.

Special designs and other coatings available upon request.

OptiMill®-Composite-TwinCut

Shoulder milling cutter, extra long design
SCM490

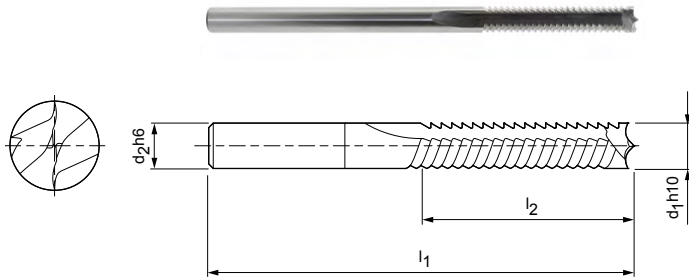

N	1.1	1.2	1.3	1.4	2.1	2.2	2.3	3.1	3.2	4.1	4.2	4.3	C	1.1	1.2	1.3	2.1	3.1	4.1	4.2	5.1	5.2	5.3
---	-----	-----	-----	-----	-----	-----	-----	-----	-----	-----	-----	-----	---	-----	-----	-----	-----	-----	-----	-----	-----	-----	-----

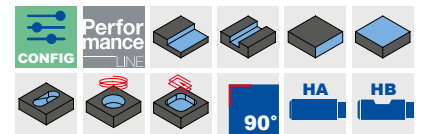

Preferred series in stock

Dimensions				z	Specification	Order no.
d ₁ h10	d ₂ h6	l ₁	l ₂			
4,00	4	75	20	2	SCM490-0400Z02R-S-HA-HU610	30402708
6,00	6	100	35	2	SCM490-0600Z02R-S-HA-HU610	30402710
8,00	8	100	40	2	SCM490-0800Z02R-S-HA-HU610	30402711

Available on request

5,00	5	75	25	2	SCM490-0500Z02R-S-HA-HU610	30402709
10,00	10	125	50	2	SCM490-1000Z02R-S-HA-HU610	30402712
12,00	12	125	60	2	SCM490-1200Z02R-S-HA-HU610	30402713
16,00	16	150	75	2	SCM490-1600Z02R-S-HA-HU610	30402714
20,00	20	104	45	2	SCM490-2000Z02R-S-HA-HU610	30402715

Configurable features

Shank form:
Shank form: HB

Specification:
SCM490-0400Z02R-S-[shank form]-HU610

Example:
SCM490-0400Z02R-S-**HB**-HU610

Shank form HB

Dimensions in mm.

For cutting data recommendations, see end of chapter.

Special designs and other coatings available upon request.

OptiMill®-Thermoplastic-FR

Shoulder milling cutter, overlong design
SCM610

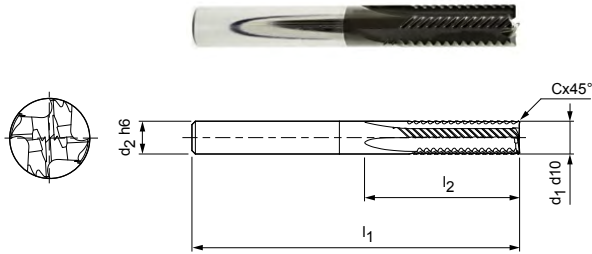

N	1.1	1.2	1.3	1.4	2.1	2.2	2.3	3.1	3.2	4.1	4.2	4.3	C	1.1	1.2	1.3	2.1	3.1	4.1	4.2	5.1	5.2	5.3
---	-----	-----	-----	-----	-----	-----	-----	-----	-----	-----	-----	-----	---	-----	-----	-----	-----	-----	-----	-----	-----	-----	-----

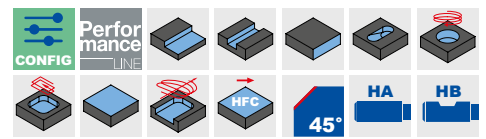

Preferred series in stock

Dimensions					z	Specification	Order no.
d ₁ h10	d ₂ h6	l ₁	l ₂	Cx45°			
6,00	6	62	13	0,12	4	SCM610-0600Z04R-F0012HA-HC614	30602341
10,00	10	80	22	0,20	4	SCM610-1000Z04R-F0020HA-HC614	30602345

Available on request

4,00	6	62	11	0,08	4	SCM610-0400Z04R-F0008HA-HC614	30602339
5,00	6	62	13	0,10	4	SCM610-0500Z04R-F0010HA-HC614	30602340
8,00	8	68	19	0,16	4	SCM610-0800Z04R-F0016HA-HC614	30602343
12,00	12	93	26	0,24	4	SCM610-1200Z04R-F0024HA-HC614	30602346
16,00	16	108	32	0,32	4	SCM610-1600Z04R-F0032HA-HC614	30602347
20,00	20	126	38	0,40	4	SCM610-2000Z04R-F0040HA-HC614	30602348

Configurable features

Shank form:
Shank form: HB

Specification:
SCM610-0600Z04R-F0012[shank form]-HC614

Example:

SCM610-0600Z04R-F0012**HB**-HC614

Shank form HB

Dimensions in mm.

For cutting data recommendations, see end of chapter.

Special designs and other coatings available upon request.

Design:

Diameter of milling cutter: 6.00 - 20.00 mm

Cutting material: HC614

Number of cutting edges: 4

Helix angle: 0°

Special features: Diamond coating

Application:

For machining thermoplastics with fibre reinforcement. Due to a special high-performance toothing, the fibres are cleanly cut off at the cutting edge without burr formation.

OptiMill®-Mono-Plastic

Shoulder milling cutter, design with pulling/pushing cutting edge
SCM330

Design:

Diameter of milling cutter: 2.00 - 12.00 mm
Cutting material: HU211
Number of cutting edges: 1
Special features: Large chip space for unhindered chip discharge

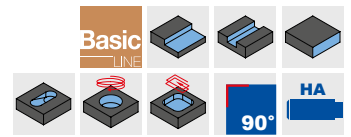
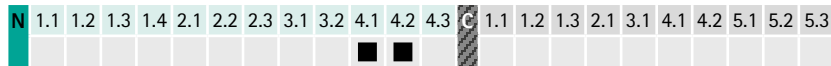
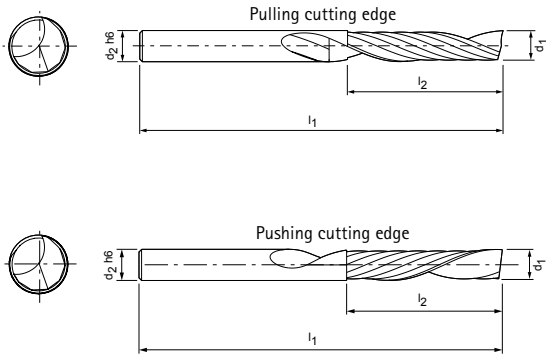

Preferred series in stock

Dimensions				z	Specification*	Order no.	
d ₁	d ₂ h6	l ₁	l ₂			pulling	pushing
2,00	3	38	8	1	SCM330-0200Z01 [cutting behaviour]-S-HA-HU211	30393650	30393681
3,00	3	38	10	1	SCM330-0300Z01 [cutting behaviour]-S-HA-HU211	30393652	30393683
3,00	4	38	10	1	SCM330-0300Z01 [cutting behaviour]-S-HA-HU211	30393653	-
3,00	4	50	15	1	SCM330-0300Z01 [cutting behaviour]-S-HA-HU211	30393654	30393685
3,00	6	50	10	1	SCM330-0300Z01 [cutting behaviour]-S-HA-HU211	30393655	30393686
4,00	4	40	12	1	SCM330-0400Z01 [cutting behaviour]-S-HA-HU211	30393659	30393688
4,00	4	60	20	1	SCM330-0400Z01 [cutting behaviour]-S-HA-HU211	30393660	-
4,00	4	70	30	1	SCM330-0400Z01 [cutting behaviour]-S-HA-HU211	30393661	-
4,00	6	50	15	1	SCM330-0400Z01 [cutting behaviour]-S-HA-HU211	30393662	30393691
5,00	5	50	16	1	SCM330-0500Z01 [cutting behaviour]-S-HA-HU211	30393665	30393695
5,00	5	70	30	1	SCM330-0500Z01 [cutting behaviour]-S-HA-HU211	30393666	-
6,00	6	60	20	1	SCM330-0600Z01 [cutting behaviour]-S-HA-HU211	30393669	30393698
6,00	6	70	30	1	SCM330-0600Z01 [cutting behaviour]-S-HA-HU211	30393670	30393699
6,00	6	80	38	1	SCM330-0600Z01 [cutting behaviour]-S-HA-HU211	30393671	-
8,00	8	60	25	1	SCM330-0800Z01 [cutting behaviour]-S-HA-HU211	30393674	30393702
8,00	8	80	38	1	SCM330-0800Z01 [cutting behaviour]-S-HA-HU211	30393675	30393703
10,00	10	75	30	1	SCM330-1000Z01 [cutting behaviour]-S-HA-HU211	30393677	-
12,00	12	75	30	1	SCM330-1200Z01 [cutting behaviour]-S-HA-HU211	30393679	-

Dimensions in mm.

For cutting data recommendations, see end of chapter.

Special designs and other coatings available upon request.

* Specification plus required soft cutting behaviour.

R = pulling | L = pushing

Cutting data recommendations for shoulder milling cutters

Feed and cutting speed

Tool length/correction factor:	
Length	f_z & v_c
Short	1
Long	0,9
Overlong	0,8
Extra long	0,6

Groove milling

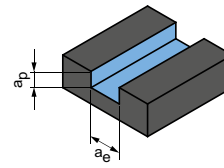

$$a_p = 1xD$$

$$a_e = 1xD$$

OptiMill-Uni-HPC-Plus | SCM720, 740, 760, 770

MMG*		Workpiece material	Strength/hardness [N/mm ²] [HRC]	Cooling			v_c [m/min]	f_z [mm]									
				MQL/Air	Dry	Coolant		Diameter of milling cutter [mm]									
								2.00	4.00	6.00	8.00	10.00	12.00	16.00	20.00		
P	P1	P1.1	Structural, free-cutting, case hardened and heat-treated steels, non-alloy	< 700	✓	✓	✓	175	0.013	0.024	0.035	0.044	0.053	0.061	0.075	0.085	
		P1.2	Structural, free-cutting, case hardened and heat-treated steels, non-alloy	< 1200	✓	✓	✓	145	0.012	0.023	0.032	0.041	0.050	0.057	0.070	0.080	
	P2	P2.1	Nitrided, case hardened and heat-treated steels, alloy	< 900	✓	✓	✓	160	0.013	0.024	0.035	0.044	0.053	0.061	0.075	0.085	
		P2.2	Nitrided, case hardened and heat-treated steels, alloy	< 1400	✓	✓	✓	110	0.011	0.020	0.029	0.037	0.044	0.051	0.062	0.071	
	P3	P3.1	Tool, bearing, spring and high-speed steels**	< 800	✓	✓	✓	105	0.012	0.023	0.034	0.043	0.051	0.059	0.072	0.082	
		P3.2	Tool, bearing, spring and high-speed steels**	< 1000	✓	✓	✓	95	0.012	0.022	0.032	0.041	0.049	0.056	0.068	0.078	
		P3.3	Tool, bearing, spring and high-speed steels**	< 1500	✓	✓	✓	85	0.011	0.021	0.030	0.038	0.046	0.053	0.065	0.074	
	P4	P4.1	Stainless steels, ferritic and martensitic		✓	✓	✓	70	0.008	0.016	0.023	0.030	0.035	0.041	0.050	0.057	
	P5	P5.1	Cast steel		✓	✓	✓	105	0.012	0.023	0.034	0.043	0.051	0.059	0.072	0.082	
P6	P6.1	Stainless cast steel, ferritic and martensitic		✓	✓	✓	70	0.006	0.011	0.016	0.021	0.025	0.028	0.035	0.040		
M	M1	M1.1	Stainless steels, austenitic	< 700	✓	✓	✓	50	0.007	0.014	0.020	0.026	0.031	0.036	0.043	0.050	
		M1.2	Stainless steels, ferritic/austenitic (duplex)	< 1000	✓	✓	✓	45	0.006	0.012	0.017	0.021	0.026	0.029	0.036	0.041	
	M2	M2.1	Stainless/heat-resistant cast steel, austenitic	< 700	✓	✓	✓	50	0.008	0.015	0.022	0.028	0.034	0.039	0.047	0.054	
	M3	M3.1	Stainless cast steel, ferritic/austenitic (duplex)	< 1000	✓	✓	✓	50	0.006	0.012	0.017	0.022	0.027	0.031	0.037	0.043	
K	K1	K1.1	Cast iron with lamellar graphite (grey cast iron), GJL	< 300	✓	✓	✓	190	0.021	0.040	0.058	0.074	0.088	0.102	0.124	0.142	
		K2.1	Cast iron with spheroidal graphite, GJS	< 500	✓	✓	✓	175	0.018	0.034	0.049	0.063	0.075	0.086	0.106	0.121	
		K2.2	Cast iron with spheroidal graphite, GJS	≤ 800	✓	✓	✓	145	0.015	0.028	0.040	0.052	0.062	0.071	0.087	0.099	
	K2	K2.3	Cast iron with spheroidal graphite, GJS	> 800	✓	✓	✓	80	0.008	0.016	0.023	0.030	0.035	0.041	0.050	0.057	
		K3	K3.1	Cast iron with spheroidal graphite, GJV; malleable cast iron, GJM	< 500	✓	✓	✓	125	0.015	0.028	0.040	0.052	0.062	0.071	0.087	0.099
			K3.2	Cast iron with spheroidal graphite, GJV; malleable cast iron, GJM	> 500	✓	✓	✓	120	0.013	0.024	0.035	0.044	0.053	0.061	0.075	0.085

OptiMill-Uni-HPC-Plus | SCM772

MMG*		Workpiece material	Strength/hardness [N/mm ²] [HRC]	Cooling			v_c [m/min]	f_z [mm]									
				MQL/Air	Dry	Coolant		Diameter of milling cutter [mm]									
								1.00	3.00	6.00	8.00	10.00	12.00	16.00	20.00		
P	P1	P1.1	Structural, free-cutting, case hardened and heat-treated steels, non-alloy	< 700	✓	✓	✓	200	0.007	0.020	0.038	0.049	0.058	0.067	0.082	0.094	
		P1.2	Structural, free-cutting, case hardened and heat-treated steels, non-alloy	< 1200	✓	✓	✓	165	0.007	0.019	0.036	0.046	0.054	0.063	0.077	0.087	
	P2	P2.1	Nitrided, case hardened and heat-treated steels, alloy	< 900	✓	✓	✓	180	0.007	0.020	0.038	0.049	0.058	0.067	0.082	0.094	
		P2.2	Nitrided, case hardened and heat-treated steels, alloy	< 1400	✓	✓	✓	125	0.006	0.017	0.032	0.041	0.049	0.056	0.068	0.078	
	P3	P3.1	Tool, bearing, spring and high-speed steels**	< 800	✓	✓	✓	120	0.007	0.020	0.037	0.047	0.056	0.065	0.079	0.091	
		P3.2	Tool, bearing, spring and high-speed steels**	< 1000	✓	✓	✓	110	0.007	0.019	0.035	0.045	0.054	0.062	0.075	0.086	
		P3.3	Tool, bearing, spring and high-speed steels**	< 1500	✓	✓	✓	100	0.006	0.018	0.033	0.042	0.051	0.058	0.071	0.081	
	P4	P4.1	Stainless steels, ferritic and martensitic		✓	✓	✓	80	0.005	0.014	0.025	0.033	0.039	0.045	0.055	0.062	
	P5	P5.1	Cast steel		✓	✓	✓	120	0.007	0.020	0.037	0.047	0.056	0.065	0.079	0.091	
P6	P6.1	Stainless cast steel, ferritic and martensitic		✓	✓	✓	80	0.003	0.010	0.018	0.023	0.027	0.031	0.038	0.044		
M	M1	M1.1	Stainless steels, austenitic	< 700	✓	✓	✓	55	0.004	0.012	0.022	0.028	0.034	0.039	0.048	0.055	
		M1.2	Stainless steels, ferritic/austenitic (duplex)	< 1000	✓	✓	✓	50	0.003	0.010	0.018	0.024	0.028	0.032	0.040	0.045	
	M2	M2.1	Stainless/heat-resistant cast steel, austenitic	< 700	✓	✓	✓	60	0.005	0.013	0.024	0.031	0.037	0.042	0.052	0.059	
	M3	M3.1	Stainless cast steel, ferritic/austenitic (duplex)	< 1000	✓	✓	✓	55	0.004	0.010	0.019	0.024	0.029	0.034	0.041	0.047	
K	K1	K1.1	Cast iron with lamellar graphite (grey cast iron), GJL	< 300	✓	✓	✓	215	0.012	0.034	0.064	0.081	0.097	0.112	0.137	0.156	
		K2.1	Cast iron with spheroidal graphite, GJS	< 500	✓	✓	✓	200	0.010	0.029	0.054	0.069	0.083	0.095	0.116	0.133	
		K2.2	Cast iron with spheroidal graphite, GJS	≤ 800	✓	✓	✓	160	0.008	0.024	0.045	0.057	0.068	0.078	0.096	0.109	
	K2	K2.3	Cast iron with spheroidal graphite, GJS	> 800	✓	✓	✓	90	0.005	0.014	0.025	0.033	0.039	0.045	0.055	0.062	
		K3	K3.1	Cast iron with spheroidal graphite, GJV; malleable cast iron, GJM	< 500	✓	✓	✓	145	0.008	0.024	0.045	0.057	0.068	0.078	0.096	0.109
			K3.2	Cast iron with spheroidal graphite, GJV; malleable cast iron, GJM	> 500	✓	✓	✓	135	0.007	0.020	0.038	0.049	0.058	0.067	0.082	0.094

* MAPAL machining groups

** If the alloy parts Cr, Mo, Ni, V, W in total > 8%, then select the next highest MAPAL machining group.

Roughing

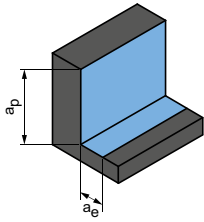

$a_p = 1.5 \times D$
 $a_e = 0.25 \times D$

Finishing

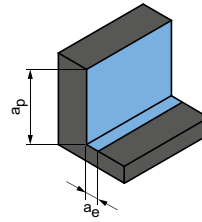

$a_p = 1.5 \times D$
 $a_e = 0.1 \times D$

	v _c [m/min]	f _z [mm]								v _c [m/min]	f _z [mm]							
		Diameter of milling cutter [mm]									Diameter of milling cutter [mm]							
		2.00	4.00	6.00	8.00	10.00	12.00	16.00	20.00		2.00	4.00	6.00	8.00	10.00	12.00	16.00	20.00
	355	0.021	0.041	0.059	0.075	0.090	0.103	0.126	0.145	525	0.034	0.065	0.093	0.119	0.142	0.164	0.200	0.228
	290	0.020	0.038	0.055	0.070	0.084	0.097	0.118	0.135	430	0.032	0.060	0.087	0.111	0.133	0.153	0.187	0.213
	325	0.021	0.041	0.059	0.075	0.090	0.103	0.126	0.145	475	0.034	0.065	0.093	0.119	0.142	0.164	0.200	0.228
	225	0.018	0.034	0.049	0.063	0.075	0.086	0.105	0.120	335	0.028	0.054	0.078	0.099	0.119	0.136	0.167	0.190
	210	0.021	0.040	0.057	0.073	0.087	0.100	0.122	0.140	310	0.033	0.063	0.090	0.115	0.138	0.158	0.193	0.221
	195	0.020	0.038	0.054	0.069	0.083	0.095	0.116	0.132	285	0.031	0.059	0.085	0.109	0.130	0.150	0.183	0.209
	180	0.019	0.035	0.051	0.065	0.078	0.090	0.110	0.125	260	0.029	0.056	0.081	0.103	0.123	0.142	0.173	0.198
	145	0.014	0.027	0.039	0.050	0.060	0.069	0.084	0.096	215	0.023	0.043	0.062	0.079	0.095	0.109	0.133	0.152
	215	0.021	0.040	0.057	0.073	0.087	0.100	0.122	0.140	320	0.033	0.063	0.090	0.115	0.138	0.158	0.193	0.221
	145	0.010	0.019	0.027	0.035	0.042	0.048	0.059	0.067	215	0.016	0.030	0.043	0.055	0.066	0.076	0.093	0.107
	95	0.012	0.024	0.034	0.044	0.053	0.060	0.074	0.084	145	0.020	0.038	0.054	0.069	0.083	0.095	0.117	0.133
	90	0.010	0.020	0.028	0.036	0.044	0.050	0.061	0.070	135	0.016	0.031	0.045	0.057	0.069	0.079	0.097	0.110
	105	0.014	0.026	0.037	0.048	0.057	0.066	0.080	0.092	155	0.021	0.041	0.059	0.075	0.090	0.104	0.127	0.145
	95	0.011	0.020	0.029	0.038	0.045	0.052	0.063	0.072	145	0.017	0.032	0.047	0.059	0.071	0.082	0.100	0.114
	390	0.036	0.068	0.098	0.125	0.150	0.172	0.211	0.241	570	0.056	0.108	0.155	0.198	0.237	0.273	0.333	0.381
	355	0.030	0.058	0.083	0.106	0.128	0.147	0.179	0.205	525	0.048	0.092	0.132	0.168	0.202	0.232	0.283	0.324
	290	0.025	0.048	0.069	0.088	0.105	0.121	0.147	0.169	430	0.040	0.076	0.109	0.139	0.166	0.191	0.233	0.267
	160	0.014	0.027	0.039	0.050	0.060	0.069	0.084	0.096	240	0.023	0.043	0.062	0.079	0.095	0.109	0.133	0.152
	260	0.025	0.048	0.069	0.088	0.105	0.121	0.147	0.169	380	0.040	0.076	0.109	0.139	0.166	0.191	0.233	0.267
	245	0.021	0.041	0.059	0.075	0.090	0.103	0.126	0.145	355	0.034	0.065	0.093	0.119	0.142	0.164	0.200	0.228

	v _c [m/min]	f _z [mm]								v _c [m/min]	f _z [mm]							
		Diameter of milling cutter [mm]									Diameter of milling cutter [mm]							
		1.00	3.00	6.00	8.00	10.00	12.00	16.00	20.00		1.00	3.00	6.00	8.00	10.00	12.00	16.00	20.00
	355	0.012	0.035	0.065	0.083	0.099	0.114	0.139	0.159	480	0.019	0.055	0.102	0.131	0.157	0.180	0.220	0.251
	290	0.011	0.032	0.060	0.077	0.092	0.106	0.130	0.148	395	0.018	0.051	0.096	0.122	0.146	0.168	0.205	0.235
	325	0.012	0.035	0.065	0.083	0.099	0.114	0.139	0.159	435	0.019	0.055	0.102	0.131	0.157	0.180	0.220	0.251
	225	0.010	0.029	0.054	0.069	0.083	0.095	0.116	0.132	305	0.016	0.045	0.085	0.109	0.130	0.150	0.183	0.209
	210	0.012	0.033	0.063	0.080	0.096	0.110	0.134	0.154	285	0.019	0.053	0.099	0.126	0.151	0.174	0.213	0.243
	195	0.011	0.032	0.059	0.076	0.091	0.104	0.127	0.146	260	0.018	0.050	0.094	0.120	0.144	0.165	0.202	0.230
	180	0.011	0.030	0.056	0.072	0.086	0.099	0.120	0.138	240	0.017	0.047	0.089	0.113	0.136	0.156	0.191	0.218
	145	0.008	0.023	0.043	0.055	0.066	0.076	0.093	0.106	195	0.013	0.036	0.068	0.087	0.104	0.120	0.147	0.168
	215	0.012	0.033	0.063	0.080	0.096	0.110	0.134	0.154	295	0.019	0.053	0.099	0.126	0.151	0.174	0.213	0.243
	145	0.006	0.016	0.030	0.039	0.046	0.053	0.065	0.074	195	0.009	0.025	0.048	0.061	0.073	0.084	0.103	0.117
	110	0.007	0.020	0.038	0.048	0.058	0.066	0.081	0.093	160	0.011	0.032	0.060	0.076	0.091	0.105	0.128	0.147
	105	0.006	0.017	0.031	0.040	0.048	0.055	0.067	0.077	150	0.009	0.026	0.049	0.063	0.076	0.087	0.106	0.121
	120	0.008	0.022	0.041	0.052	0.063	0.072	0.088	0.101	180	0.012	0.035	0.065	0.083	0.099	0.114	0.139	0.159
	110	0.006	0.017	0.032	0.041	0.050	0.057	0.070	0.079	160	0.010	0.027	0.051	0.065	0.078	0.090	0.110	0.126
	440	0.020	0.058	0.108	0.138	0.165	0.190	0.232	0.265	650	0.032	0.091	0.171	0.218	0.261	0.300	0.366	0.419
	405	0.017	0.049	0.092	0.117	0.140	0.161	0.197	0.225	595	0.027	0.077	0.145	0.185	0.222	0.255	0.311	0.356
	330	0.014	0.040	0.076	0.096	0.116	0.133	0.162	0.185	485	0.022	0.064	0.119	0.153	0.183	0.210	0.256	0.293
	185	0.008	0.023	0.043	0.055	0.066	0.076	0.093	0.106	270	0.013	0.036	0.068	0.087	0.104	0.120	0.147	0.168
	295	0.014	0.040	0.076	0.096	0.116	0.133	0.162	0.185	430	0.022	0.064	0.119	0.153	0.183	0.210	0.256	0.293
	275	0.012	0.035	0.065	0.083	0.099	0.114	0.139	0.159	405	0.019	0.055	0.102	0.131	0.157	0.180	0.220	0.251

The specified machining values are guide values.
The optimum data for the respective machining task should be determined during the test or machining.

Cutting data recommendations for shoulder milling cutters

Feed and cutting speed

Tool length/correction factor:	
Length	f_z & v_c
A/B	1.0
C	0.9
D	0.7
E	0.6

Groove milling

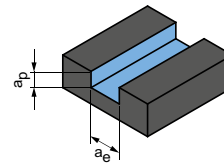

$$a_p = 0.6 \times D$$

$$a_e = 1 \times D$$

CPMill-Uni-HPC | CPM100

MMG*	Workpiece material	Strength/hardness [N/mm ²] [HRC]	Cooling			v_c [m/min]	f_z [mm]						
			MQL/Air	Dry	Coolant		Diameter of milling cutter [mm]						
							8.00	10.00	12.00	16.00	20.00	25.00	
P	P1.1	Structural, free-cutting, case hardened and heat-treated steels, non-alloy	< 700	✓	✓	✓	160	0.021	0.025	0.028	0.034	0.039	0.044
	P1.2	Structural, free-cutting, case hardened and heat-treated steels, non-alloy	< 1200	✓	✓	✓	130	0.019	0.023	0.026	0.032	0.037	0.041
	P2.1	Nitrided, case hardened and heat-treated steels, alloy	< 900	✓	✓	✓	145	0.021	0.025	0.028	0.034	0.039	0.044
	P2.2	Nitrided, case hardened and heat-treated steels, alloy	< 1400	✓	✓	✓	100	0.017	0.020	0.024	0.029	0.033	0.037
	P3.1	Tool, bearing, spring and high-speed steels**	< 800	✓	✓	✓	95	0.020	0.024	0.027	0.033	0.038	0.043
	P3.2	Tool, bearing, spring and high-speed steels**	< 1000	✓	✓	✓	85	0.019	0.023	0.026	0.032	0.036	0.040
	P3.3	Tool, bearing, spring and high-speed steels**	< 1500	✓	✓	✓	80	0.018	0.021	0.024	0.030	0.034	0.038
P5	P5.1	Stainless steels, ferritic and martensitic				✓	95	0.020	0.024	0.027	0.033	0.038	0.043
K	K1.1	Cast iron with lamellar graphite (grey cast iron), GJL	< 300	✓	✓	✓	175	0.034	0.041	0.047	0.057	0.066	0.073
	K2.1	Cast iron with spheroidal graphite, GJS	< 500	✓	✓	✓	160	0.029	0.035	0.040	0.049	0.056	0.062
	K2.2	Cast iron with spheroidal graphite, GJS	≤ 800	✓	✓	✓	130	0.024	0.029	0.033	0.040	0.046	0.051
	K2.3	Cast iron with spheroidal graphite, GJS	> 800	✓	✓	✓	70	0.014	0.016	0.019	0.023	0.026	0.029
	K3.1	Cast iron with spheroidal graphite, GJV; malleable cast iron, GJM	< 500	✓	✓	✓	115	0.024	0.029	0.033	0.040	0.046	0.051
	K3.2	Cast iron with spheroidal graphite, GJV; malleable cast iron, GJM	> 500	✓	✓	✓	110	0.021	0.025	0.028	0.034	0.039	0.044

CPMill-Uni-HPC-Slot | CPM110

MMG*	Workpiece material	Strength/hardness [N/mm ²] [HRC]	Cooling			v_c [m/min]	f_z [mm]						
			MQL/Air	Dry	Coolant		Diameter of milling cutter [mm]						
							8.00	10.00	12.00	16.00	20.00	25.00	
P	P1.1	Structural, free-cutting, case hardened and heat-treated steels, non-alloy	< 700	✓	✓	✓	160	0.021	0.025	0.028	0.034	0.039	0.044
	P1.2	Structural, free-cutting, case hardened and heat-treated steels, non-alloy	< 1200	✓	✓	✓	130	0.019	0.023	0.026	0.032	0.037	0.041
	P2.1	Nitrided, case hardened and heat-treated steels, alloy	< 900	✓	✓	✓	145	0.021	0.025	0.028	0.034	0.039	0.044
	P2.2	Nitrided, case hardened and heat-treated steels, alloy	< 1400	✓	✓	✓	100	0.017	0.020	0.024	0.029	0.033	0.037
	P3.1	Tool, bearing, spring and high-speed steels**	< 800	✓	✓	✓	95	0.020	0.024	0.027	0.033	0.038	0.043
	P3.2	Tool, bearing, spring and high-speed steels**	< 1000	✓	✓	✓	85	0.019	0.023	0.026	0.032	0.036	0.040
	P3.3	Tool, bearing, spring and high-speed steels**	< 1500	✓	✓	✓	80	0.018	0.021	0.024	0.030	0.034	0.038
P5	P5.1	Stainless steels, ferritic and martensitic				✓	95	0.020	0.024	0.027	0.033	0.038	0.043
K	K1.1	Cast iron with lamellar graphite (grey cast iron), GJL	< 300	✓	✓	✓	175	0.034	0.041	0.047	0.057	0.066	0.073
	K2.1	Cast iron with spheroidal graphite, GJS	< 500	✓	✓	✓	160	0.029	0.035	0.040	0.049	0.056	0.062
	K2.2	Cast iron with spheroidal graphite, GJS	≤ 800	✓	✓	✓	130	0.024	0.029	0.033	0.040	0.046	0.051
	K2.3	Cast iron with spheroidal graphite, GJS	> 800	✓	✓	✓	70	0.014	0.016	0.019	0.023	0.026	0.029
	K3.1	Cast iron with spheroidal graphite, GJV; malleable cast iron, GJM	< 500	✓	✓	✓	115	0.024	0.029	0.033	0.040	0.046	0.051
	K3.2	Cast iron with spheroidal graphite, GJV; malleable cast iron, GJM	> 500	✓	✓	✓	110	0.021	0.025	0.028	0.034	0.039	0.044

* MAPAL machining groups

** If the alloy parts Cr, Mo, Ni, V, W in total > 8%, then select the next highest MAPAL machining group.

Roughing

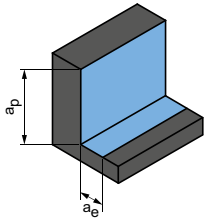

$$a_p = 0.56 \times D$$

$$a_e = 0.5 \times D$$

Finishing

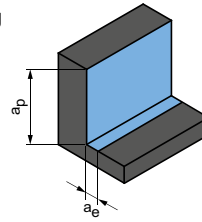

$$a_p = 0.56 \times D$$

$$a_e = 0.1 \times D$$

	v_c [m/min]	f_z [mm]						v_c [m/min]	f_z [mm]					
		Diameter of milling cutter [mm]							Diameter of milling cutter [mm]					
		8.00	10.00	12.00	16.00	20.00	25.00		8.00	10.00	12.00	16.00	20.00	25.00
	285	0.041	0.049	0.056	0.069	0.079	0.088	385	0.065	0.078	0.089	0.109	0.125	0.139
	235	0.038	0.046	0.053	0.064	0.074	0.082	315	0.061	0.072	0.083	0.102	0.116	0.130
	260	0.041	0.049	0.056	0.069	0.079	0.088	350	0.065	0.078	0.089	0.109	0.125	0.139
	180	0.034	0.041	0.047	0.057	0.066	0.073	245	0.054	0.065	0.074	0.091	0.104	0.116
	170	0.040	0.047	0.055	0.067	0.076	0.085	225	0.063	0.075	0.086	0.105	0.120	0.134
	155	0.038	0.045	0.052	0.063	0.072	0.081	210	0.059	0.071	0.082	0.100	0.114	0.127
	145	0.036	0.043	0.049	0.060	0.068	0.076	190	0.056	0.067	0.077	0.094	0.108	0.121
	175	0.040	0.047	0.055	0.067	0.076	0.085	235	0.063	0.075	0.086	0.105	0.120	0.134
	355	0.068	0.082	0.094	0.115	0.131	0.147	520	0.108	0.129	0.149	0.182	0.208	0.232
	325	0.058	0.070	0.080	0.098	0.112	0.125	475	0.092	0.110	0.126	0.154	0.177	0.197
	265	0.048	0.057	0.066	0.080	0.092	0.103	390	0.076	0.091	0.104	0.127	0.145	0.162
	145	0.027	0.033	0.038	0.046	0.053	0.059	215	0.043	0.052	0.059	0.073	0.083	0.093
	235	0.048	0.057	0.066	0.080	0.092	0.103	345	0.076	0.091	0.104	0.127	0.145	0.162
	220	0.041	0.049	0.056	0.069	0.079	0.088	325	0.065	0.078	0.089	0.109	0.125	0.139

	v_c [m/min]	f_z [mm]						v_c [m/min]	f_z [mm]					
		Diameter of milling cutter [mm]							Diameter of milling cutter [mm]					
		8.00	10.00	12.00	16.00	20.00	25.00		8.00	10.00	12.00	16.00	20.00	25.00
	285	0.041	0.049	0.056	0.069	0.079	0.088	385	0.065	0.078	0.089	0.109	0.125	0.139
	235	0.038	0.046	0.053	0.064	0.074	0.082	315	0.061	0.072	0.083	0.102	0.116	0.130
	260	0.041	0.049	0.056	0.069	0.079	0.088	350	0.065	0.078	0.089	0.109	0.125	0.139
	180	0.034	0.041	0.047	0.057	0.066	0.073	245	0.054	0.065	0.074	0.091	0.104	0.116
	170	0.040	0.047	0.055	0.067	0.076	0.085	225	0.063	0.075	0.086	0.105	0.120	0.134
	155	0.038	0.045	0.052	0.063	0.072	0.081	210	0.059	0.071	0.082	0.100	0.114	0.127
	145	0.036	0.043	0.049	0.060	0.068	0.076	190	0.056	0.067	0.077	0.094	0.108	0.121
	175	0.040	0.047	0.055	0.067	0.076	0.085	235	0.063	0.075	0.086	0.105	0.120	0.134
	355	0.068	0.082	0.094	0.115	0.131	0.147	520	0.108	0.129	0.149	0.182	0.208	0.232
	325	0.058	0.070	0.080	0.098	0.112	0.125	475	0.092	0.110	0.126	0.154	0.177	0.197
	265	0.048	0.057	0.066	0.080	0.092	0.103	390	0.076	0.091	0.104	0.127	0.145	0.162
	145	0.027	0.033	0.038	0.046	0.053	0.059	215	0.043	0.052	0.059	0.073	0.083	0.093
	235	0.048	0.057	0.066	0.080	0.092	0.103	345	0.076	0.091	0.104	0.127	0.145	0.162
	220	0.041	0.049	0.056	0.069	0.079	0.088	325	0.065	0.078	0.089	0.109	0.125	0.139

The specified machining values are guide values.
The optimum data for the respective machining task should be determined during the test or machining.

Cutting data recommendations for shoulder milling cutters

Feed and cutting speed

Tool length/correction factor:	
Length	f _z & v _c
Short	1
Long	0,9
Overlong	0,8
Extra long	0,6

Groove milling

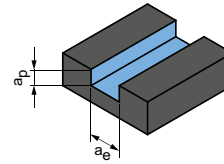

$$a_p = 1 \times D$$

$$a_e = 1 \times D$$

OptiMill-Uni-HPC-Slot | SCM250

MMG*	Workpiece material	Strength/hardness [N/mm ²] [HRC]	Cooling			v _c [m/min]	f _z [mm]									
			MQL/Air	Dry	Coolant		Diameter of milling cutter [mm]									
							2.00	4.00	6.00	8.00	10.00	12.00	16.00	20.00		
P	P1.1	Structural, free-cutting, case hardened and heat-treated steels, non-alloy	< 700	✓	✓	✓	200	0.013	0.024	0.035	0.044	0.053	0.061	0.075	0.085	
	P1.2	Structural, free-cutting, case hardened and heat-treated steels, non-alloy	< 1200	✓	✓	✓	165	0.012	0.023	0.032	0.041	0.050	0.057	0.070	0.080	
	P2.1	Nitrided, case hardened and heat-treated steels, alloy	< 900	✓	✓	✓	180	0.013	0.024	0.035	0.044	0.053	0.061	0.075	0.085	
	P2.2	Nitrided, case hardened and heat-treated steels, alloy	< 1400	✓	✓	✓	125	0.011	0.020	0.029	0.037	0.044	0.051	0.062	0.071	
	P3.1	Tool, bearing, spring and high-speed steels**	< 800	✓	✓	✓	120	0.012	0.023	0.034	0.043	0.051	0.059	0.072	0.082	
	P3.2	Tool, bearing, spring and high-speed steels**	< 1000	✓	✓	✓	110	0.012	0.022	0.032	0.041	0.049	0.056	0.068	0.078	
	P3.3	Tool, bearing, spring and high-speed steels**	< 1500	✓	✓	✓	100	0.011	0.021	0.030	0.038	0.046	0.053	0.065	0.074	
	P4	P4.1	Stainless steels, ferritic and martensitic		✓	✓	80	0.008	0.016	0.023	0.030	0.035	0.041	0.050	0.057	
P5	P5.1	Cast steel			✓	120	0.012	0.023	0.034	0.043	0.051	0.059	0.072	0.082		
P6	P6.1	Stainless cast steel, ferritic and martensitic			✓	80	0.006	0.011	0.016	0.021	0.025	0.028	0.035	0.040		
M	M1.1	Stainless steels, austenitic	< 700	✓		✓	55	0.007	0.014	0.020	0.026	0.031	0.036	0.043	0.050	
	M1.2	Stainless steels, ferritic/austenitic (duplex)	< 1000			✓	50	0.006	0.012	0.017	0.021	0.026	0.029	0.036	0.041	
	M2	M2.1	Stainless cast steel, austenitic	< 700	✓		✓	60	0.008	0.015	0.022	0.028	0.034	0.039	0.047	0.054
	M3	M3.1	Stainless cast steel, ferritic/austenitic (Duplex)	< 1000			✓	55	0.006	0.012	0.017	0.022	0.027	0.031	0.037	0.043
K	K1	K1.1	Cast iron with lamellar graphite (grey cast iron), GJL	< 300	✓	✓	✓	215	0.021	0.040	0.058	0.074	0.088	0.102	0.124	0.142
	K2	K2.1	Cast iron with spheroidal graphite, GJS	< 500	✓	✓	✓	200	0.018	0.034	0.049	0.063	0.075	0.086	0.106	0.121
	K2	K2.2	Cast iron with spheroidal graphite, GJS	≤ 800	✓	✓	✓	160	0.015	0.028	0.040	0.052	0.062	0.071	0.087	0.099
	K2	K2.3	Cast iron with spheroidal graphite, GJS	> 800	✓	✓	✓	90	0.008	0.016	0.023	0.030	0.035	0.041	0.050	0.057
	K3	K3.1	Cast iron with vermicular graphite, GJV; malleable cast iron, GJM	< 500	✓	✓	✓	145	0.015	0.028	0.040	0.052	0.062	0.071	0.087	0.099
	K3	K3.2	Cast iron with vermicular graphite, GJV; malleable cast iron, GJM	> 500	✓	✓	✓	135	0.013	0.024	0.035	0.044	0.053	0.061	0.075	0.085

ECU-Mill-Uni-LV | SCM780.790

MMG*	Workpiece material	Strength/hardness [N/mm ²] [HRC]	Cooling			v _c [m/min]	f _z [mm]								
			MQL/Air	Dry	Coolant		Diameter of milling cutter [mm]								
							6.00	8.00	10.00	12.00	16.00	20.00	25.00		
P	P1.1	Structural, free-cutting, case hardened and heat-treated steels, non-alloy	< 700	✓	✓	✓	170	0.022	0.031	0.040	0.048	0.055	0.067	0.077	
	P1.2	Structural, free-cutting, case hardened and heat-treated steels, non-alloy	< 1200	✓	✓	✓	140	0.020	0.029	0.037	0.045	0.051	0.063	0.072	
	P2.1	Nitrided, case hardened and heat-treated steels, alloy	< 900	✓	✓	✓	155	0.022	0.031	0.040	0.048	0.055	0.067	0.077	
	P2.2	Nitrided, case hardened and heat-treated steels, alloy	< 1400	✓	✓	✓	110	0.018	0.026	0.033	0.040	0.046	0.056	0.064	
	P3.1	Tool, bearing, spring and high-speed steels**	< 800	✓	✓	✓	100	0.021	0.030	0.039	0.046	0.053	0.065	0.074	
	P3.2	Tool, bearing, spring and high-speed steels**	< 1000	✓	✓	✓	95	0.020	0.029	0.037	0.044	0.050	0.061	0.070	
	P3.3	Tool, bearing, spring and high-speed steels**	< 1500	✓	✓	✓	85	0.019	0.027	0.035	0.041	0.048	0.058	0.066	
	P5	P5.1	Cast steel			✓	105	0.021	0.030	0.039	0.046	0.053	0.065	0.074	
K	K1	K1.1	Cast iron with lamellar graphite (grey cast iron), GJL	< 300	✓	✓	✓	185	0.036	0.052	0.066	0.080	0.092	0.112	0.128
	K2	K2.1	Cast iron with spheroidal graphite, GJS	< 500	✓	✓	✓	170	0.031	0.044	0.057	0.068	0.078	0.095	0.109
	K2	K2.2	Cast iron with spheroidal graphite, GJS	≤ 800	✓	✓	✓	140	0.025	0.036	0.047	0.056	0.064	0.078	0.089
	K2	K2.3	Cast iron with spheroidal graphite, GJS	> 800	✓	✓	✓	75	0.014	0.021	0.027	0.032	0.037	0.045	0.051
	K3	K3.1	Cast iron with spheroidal graphite, GJV; malleable cast iron, GJM	< 500	✓	✓	✓	120	0.025	0.036	0.047	0.056	0.064	0.078	0.089
	K3	K3.2	Cast iron with spheroidal graphite, GJV; malleable cast iron, GJM	> 500	✓	✓	✓	115	0.022	0.031	0.040	0.048	0.055	0.067	0.077

* MAPAL machining groups

** If the alloy parts Cr, Mo, Ni, V, W in total > 8%, then select the next highest MAPAL machining group.

Roughing

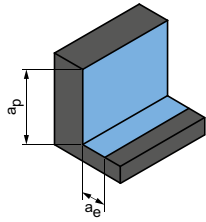

$a_p = 1.5xD$
 $a_e = 0.25xD$

Finishing

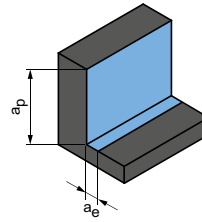

$a_p = 1.5xD$
 $a_e = 0.1xD$

	v_c [m/min]	f_z [mm]								v_c [m/min]	f_z [mm]							
		Diameter of milling cutter [mm]									Diameter of milling cutter [mm]							
		2.00	4.00	6.00	8.00	10.00	12.00	16.00	20.00		2.00	4.00	6.00	8.00	10.00	12.00	16.00	20.00
	355	0.021	0.041	0.059	0.075	0.090	0.103	0.126	0.145	480	0.034	0.065	0.093	0.119	0.142	0.164	0.200	0.228
	290	0.020	0.038	0.055	0.070	0.084	0.097	0.118	0.135	395	0.032	0.060	0.087	0.111	0.133	0.153	0.187	0.213
	325	0.021	0.041	0.059	0.075	0.090	0.103	0.126	0.145	435	0.034	0.065	0.093	0.119	0.142	0.164	0.200	0.228
	225	0.018	0.034	0.049	0.063	0.075	0.086	0.105	0.120	305	0.028	0.054	0.078	0.099	0.119	0.136	0.167	0.190
	210	0.021	0.040	0.057	0.073	0.087	0.100	0.122	0.140	285	0.033	0.063	0.090	0.115	0.138	0.158	0.193	0.221
	195	0.020	0.038	0.054	0.069	0.083	0.095	0.116	0.132	260	0.031	0.059	0.085	0.109	0.130	0.150	0.183	0.209
	180	0.019	0.035	0.051	0.065	0.078	0.090	0.110	0.125	240	0.029	0.056	0.081	0.103	0.123	0.142	0.173	0.198
	145	0.014	0.027	0.039	0.050	0.060	0.069	0.084	0.096	195	0.023	0.043	0.062	0.079	0.095	0.109	0.133	0.152
	215	0.021	0.040	0.057	0.073	0.087	0.100	0.122	0.140	295	0.033	0.063	0.090	0.115	0.138	0.158	0.193	0.221
	145	0.010	0.019	0.027	0.035	0.042	0.048	0.059	0.067	195	0.016	0.030	0.043	0.055	0.066	0.076	0.093	0.107
	110	0.012	0.024	0.034	0.044	0.053	0.060	0.074	0.084	160	0.020	0.038	0.054	0.069	0.083	0.095	0.117	0.133
	105	0.010	0.020	0.028	0.036	0.044	0.050	0.061	0.070	150	0.016	0.031	0.045	0.057	0.069	0.079	0.097	0.110
	120	0.014	0.026	0.037	0.048	0.057	0.066	0.080	0.092	180	0.021	0.041	0.059	0.075	0.090	0.104	0.127	0.145
	110	0.011	0.020	0.029	0.038	0.045	0.052	0.063	0.072	160	0.017	0.032	0.047	0.059	0.071	0.082	0.100	0.114
	440	0.036	0.068	0.098	0.125	0.150	0.172	0.211	0.241	650	0.056	0.108	0.155	0.198	0.237	0.273	0.333	0.381
	405	0.030	0.058	0.083	0.106	0.128	0.147	0.179	0.205	595	0.048	0.092	0.132	0.168	0.202	0.232	0.283	0.324
	330	0.025	0.048	0.069	0.088	0.105	0.121	0.147	0.169	485	0.040	0.076	0.109	0.139	0.166	0.191	0.233	0.267
	185	0.014	0.027	0.039	0.050	0.060	0.069	0.084	0.096	270	0.023	0.043	0.062	0.079	0.095	0.109	0.133	0.152
	295	0.025	0.048	0.069	0.088	0.105	0.121	0.147	0.169	430	0.040	0.076	0.109	0.139	0.166	0.191	0.233	0.267
	275	0.021	0.041	0.059	0.075	0.090	0.103	0.126	0.145	405	0.034	0.065	0.093	0.119	0.142	0.164	0.200	0.228

	v_c [m/min]	f_z [mm]							v_c [m/min]	f_z [mm]						
		Diameter of milling cutter [mm]								Diameter of milling cutter [mm]						
		6.00	8.00	10.00	12.00	16.00	20.00	25.00		6.00	8.00	10.00	12.00	16.00	20.00	25.00
	305	0.043	0.062	0.080	0.096	0.110	0.134	0.153	410	0.069	0.099	0.126	0.151	0.174	0.212	0.242
	250	0.041	0.058	0.074	0.089	0.102	0.125	0.143	335	0.064	0.092	0.118	0.141	0.162	0.198	0.226
	275	0.043	0.062	0.080	0.096	0.110	0.134	0.153	370	0.069	0.099	0.126	0.151	0.174	0.212	0.242
	195	0.036	0.052	0.066	0.080	0.092	0.112	0.128	260	0.057	0.082	0.105	0.126	0.145	0.177	0.202
	180	0.042	0.060	0.077	0.092	0.106	0.130	0.148	240	0.066	0.095	0.122	0.146	0.168	0.205	0.234
	165	0.040	0.057	0.073	0.088	0.101	0.123	0.141	225	0.063	0.090	0.116	0.138	0.159	0.194	0.222
	150	0.038	0.054	0.069	0.083	0.095	0.116	0.133	205	0.060	0.086	0.109	0.131	0.150	0.184	0.210
	185	0.042	0.060	0.077	0.092	0.106	0.130	0.148	250	0.066	0.095	0.122	0.146	0.168	0.205	0.234
	375	0.072	0.104	0.133	0.159	0.183	0.224	0.256	550	0.114	0.165	0.210	0.252	0.289	0.353	0.404
	345	0.062	0.088	0.113	0.135	0.156	0.190	0.217	505	0.097	0.140	0.179	0.214	0.246	0.300	0.344
	280	0.051	0.073	0.093	0.111	0.128	0.156	0.179	415	0.080	0.115	0.147	0.176	0.203	0.247	0.283
	155	0.029	0.042	0.053	0.064	0.073	0.089	0.102	230	0.046	0.066	0.084	0.101	0.116	0.141	0.162
	250	0.051	0.073	0.093	0.111	0.128	0.156	0.179	365	0.080	0.115	0.147	0.176	0.203	0.247	0.283
	235	0.043	0.062	0.080	0.096	0.110	0.134	0.153	345	0.069	0.099	0.126	0.151	0.174	0.212	0.242

The specified machining values are guide values.
The optimum data for the respective machining task should be determined during the test or machining.

Cutting data recommendations for shoulder milling cutters

Feed and cutting speed

Tool length/correction factor:	
Length	f_z & v_c
short	1
Long	1
Overlong	0.8
Extra long	-

Roughing

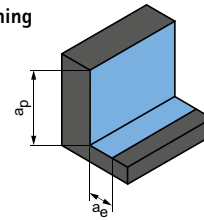

$$a_p = 1.5 \times D$$

$$a_e = 0.25 \times D$$

OptiMill-Uni-HPC-Pocket | SCM800, 810, 840

MMG*	Workpiece material	Strength/hardness [N/mm ²] [HRC]	Cooling			v_c [m/min]	f_z [mm]							
			MQL/Air	Dry	Coolant		Diameter of milling cutter [mm]							
							3.80	6.00	8.00	10.00	12.00	16.00	20.00	
P	P1.1	Structural, free-cutting, case hardened and heat-treated steels, non-alloy	< 700	✓	✓	✓	465	0.053	0.079	0.101	0.122	0.140	0.171	0.195
	P1.2	Structural, free-cutting, case hardened and heat-treated steels, non-alloy	< 1200	✓	✓	✓	380	0.049	0.074	0.095	0.113	0.130	0.159	0.182
	P2.1	Nitrided, case hardened and heat-treated steels, alloy	< 900	✓	✓	✓	425	0.053	0.079	0.101	0.122	0.140	0.171	0.195
	P2.2	Nitrided, case hardened and heat-treated steels, alloy	< 1400	✓	✓	✓	295	0.044	0.066	0.085	0.101	0.116	0.142	0.163
	P3.1	Tool, bearing, spring and high-speed steels**	< 800	✓	✓	✓	275	0.051	0.077	0.098	0.117	0.135	0.165	0.189
	P3.2	Tool, bearing, spring and high-speed steels**	< 1000	✓	✓	✓	255	0.048	0.073	0.093	0.111	0.128	0.156	0.179
	P3.3	Tool, bearing, spring and high-speed steels**	< 1500	✓	✓	✓	235	0.046	0.069	0.088	0.105	0.121	0.148	0.169
	P4.1	Stainless steels, ferritic and martensitic		✓	✓	✓	190	0.035	0.053	0.068	0.081	0.093	0.114	0.130
	P5.1	Cast steel		✓	✓	✓	285	0.051	0.077	0.098	0.117	0.135	0.165	0.189
P6.1	Stainless cast steel, ferritic and martensitic		✓	✓	✓	190	0.025	0.037	0.047	0.057	0.065	0.080	0.091	
M	M1.1	Stainless steels, austenitic	< 700	✓	✓	✓	125	0.031	0.046	0.059	0.071	0.081	0.100	0.114
	M1.2	Stainless steels, ferritic/austenitic (duplex)	< 1000	✓	✓	✓	120	0.025	0.038	0.049	0.059	0.068	0.082	0.094
	M2.1	Stainless/heat-resistant cast steel, austenitic	< 700	✓	✓	✓	140	0.033	0.050	0.064	0.077	0.088	0.108	0.124
	M3.1	Stainless cast steel, ferritic/austenitic (duplex)	< 1000	✓	✓	✓	125	0.026	0.040	0.051	0.061	0.070	0.085	0.098
K	K1.1	Cast iron with lamellar graphite (grey cast iron), GJL	< 300	✓	✓	✓	510	0.088	0.132	0.169	0.203	0.233	0.284	0.325
	K2.1	Cast iron with spheroidal graphite, GJS	< 500	✓	✓	✓	465	0.075	0.113	0.144	0.172	0.198	0.242	0.276
	K2.2	Cast iron with spheroidal graphite, GJS	≤ 800	✓	✓	✓	380	0.062	0.093	0.118	0.142	0.163	0.199	0.228
	K2.3	Cast iron with spheroidal graphite, GJS	> 800	✓	✓	✓	210	0.035	0.053	0.068	0.081	0.093	0.114	0.130
	K3.1	Cast iron with spheroidal graphite, GJV; malleable cast iron, GJM	< 500	✓	✓	✓	340	0.062	0.093	0.118	0.142	0.163	0.199	0.228
	K3.2	Cast iron with spheroidal graphite, GJV; malleable cast iron, GJM	> 500	✓	✓	✓	315	0.053	0.079	0.101	0.122	0.140	0.171	0.195

Part-contact cutting

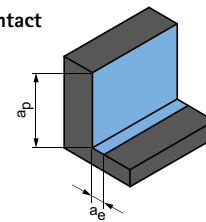

$$a_p = 1.5 \times D$$

$$a_e = 0.25 \times D$$

OptiMill-Alu-HPC-Pocket | SCM850

MMG*	Workpiece material	Strength/hardness [N/mm ²] [HRC]	Cooling			v_c [m/min]	f_z [mm]							
			MQL/Air	Dry	Coolant		Diameter of milling cutter [mm]							
							5.00	8.00	10.00	12.00	16.00	20.00		
N	N1	N1.1	Aluminium, non-alloy and alloy < 3 % Si	✓	✓	✓	945	0.080	0.120	0.145	0.169	0.210	0.243	
		N1.2	Aluminium, alloy ≤ 7 % Si	✓	✓	✓	625	0.084	0.126	0.152	0.177	0.221	0.256	
		N1.3	Aluminium, alloy > 7-12 % Si	✓	✓	✓	500	0.088	0.132	0.160	0.186	0.231	0.268	
		N1.4	Aluminium, alloy > 12 % Si	✓	✓	✓	360	0.096	0.144	0.174	0.202	0.252	0.292	
	N2	N2.1	Copper, non-alloy and low-alloy	< 300	✓	✓	✓	360	0.064	0.096	0.116	0.135	0.168	0.195
		N2.2	Copper, alloy	> 300	✓	✓	✓	270	0.064	0.096	0.116	0.135	0.168	0.195
		N2.3	Brass, bronze, gunmetal	< 1200	✓	✓	✓	450	0.040	0.060	0.073	0.084	0.105	0.122
	N4	N4.1	Plastic, thermoplastics		✓	✓	✓	125	0.040	0.060	0.073	0.084	0.105	0.122
		N4.2	Plastic, thermosets		✓	✓	✓	185	0.040	0.060	0.073	0.084	0.105	0.122
N4.3		Plastic, foams		✓	✓	✓	565	0.024	0.036	0.044	0.051	0.063	0.073	

* MAPAL machining groups

** If the alloy parts Cr, Mo, Ni, V, W in total > 8%, then select the next highest MAPAL machining group.

Groove milling

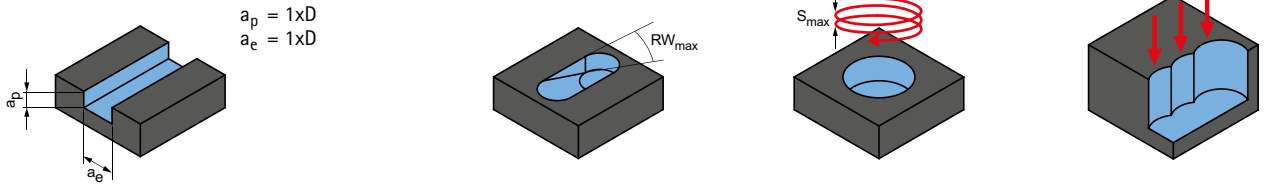

v_c [m/min]	f_z [mm]							Ramps	Helix milling		Drilling	
	Diameter of milling cutter [mm]							RW_{max}	S_{max}	EW_{max}		f_z factor
	3.80	6.00	8.00	10.00	12.00	16.00	20.00			G = 1.5	G = 1.8	
230	0.031	0.047	0.060	0.072	0.082	0.101	0.115	45°	0.75xD	25°	16°	0.9
185	0.029	0.044	0.056	0.067	0.077	0.094	0.107	45°	0.75xD	25°	16°	0.8
205	0.031	0.047	0.060	0.072	0.082	0.101	0.115	45°	0.75xD	25°	16°	0.8
145	0.026	0.039	0.050	0.060	0.069	0.084	0.096	45°	0.75xD	25°	16°	0.7
135	0.030	0.045	0.058	0.069	0.080	0.097	0.111	30°	0.5xD	18°	11°	0.8
125	0.029	0.043	0.055	0.066	0.075	0.092	0.105	30°	0.5xD	18°	11°	0.7
115	0.027	0.041	0.052	0.062	0.071	0.087	0.100	30°	0.5xD	18°	11°	0.7
95	0.021	0.031	0.040	0.048	0.055	0.067	0.077	15°	0.5xD	18°	11°	
140	0.030	0.045	0.058	0.069	0.080	0.097	0.111	30°	0.5xD	18°	11°	
95	0.015	0.022	0.028	0.033	0.038	0.047	0.054	15°	0.5xD	18°	11°	
60	0.018	0.027	0.035	0.042	0.048	0.059	0.067	15°	0.5xD	18°	11°	
60	0.015	0.023	0.029	0.035	0.040	0.049	0.056	15°	0.5xD	18°	11°	
70	0.020	0.030	0.038	0.045	0.052	0.064	0.073	15°	0.5xD	18°	11°	
60	0.016	0.023	0.030	0.036	0.041	0.050	0.058	15°	0.5xD	18°	11°	
250	0.052	0.078	0.100	0.119	0.137	0.168	0.192	45°	0.75xD	25°	16°	0.8
230	0.044	0.066	0.085	0.102	0.117	0.143	0.163	45°	0.75xD	25°	16°	0.8
185	0.036	0.055	0.070	0.084	0.096	0.117	0.134	45°	0.75xD	25°	16°	0.8
105	0.021	0.031	0.040	0.048	0.055	0.067	0.077	45°	0.75xD	25°	16°	0.8
165	0.036	0.055	0.070	0.084	0.096	0.117	0.134	45°	0.75xD	25°	16°	0.8
155	0.031	0.047	0.060	0.072	0.082	0.101	0.115	45°	0.75xD	25°	16°	0.8

Full cutting

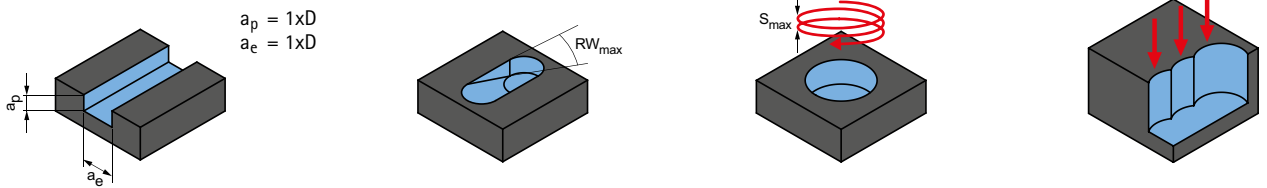

v_c [m/min]	f_z [mm]						Ramps	Helix milling		Drilling	
	Diameter of milling cutter [mm]						RW_{max}	S_{max}	EW_{max}		f_z factor
	5.00	8.00	10.00	12.00	16.00	20.00			G = 1.5	G = 1.8	
610	0.047	0.071	0.086	0.099	0.124	0.144	45°	0.75xD	25°	16°	0.8
405	0.049	0.074	0.090	0.104	0.130	0.151	45°	0.75xD	25°	16°	0.8
325	0.052	0.078	0.094	0.109	0.136	0.158	45°	0.75xD	25°	16°	0.8
235	0.057	0.085	0.103	0.119	0.149	0.172	45°	0.75xD	25°	16°	0.8
235	0.038	0.057	0.068	0.080	0.099	0.115	45°	0.75xD	25°	16°	0.8
175	0.038	0.057	0.068	0.080	0.099	0.115	45°	0.75xD	25°	16°	0.8
295	0.024	0.035	0.043	0.050	0.062	0.072	45°	0.75xD	25°	16°	0.8
80	0.024	0.035	0.043	0.050	0.062	0.072	45°	0.75xD	25°	16°	0.8
120	0.024	0.035	0.043	0.050	0.062	0.072	45°	0.75xD	25°	16°	0.8
365	0.014	0.021	0.026	0.030	0.037	0.043	45°	0.75xD	25°	16°	0.8

Explanation of terms:

RW_{max} = Maximum angle of the ramp

S_{max} = Maximum slope of the helix

G = Ratio of circular pocket \emptyset when plunging to the tool \emptyset

E.g.: Tool \emptyset 12 mm at G=1.5 results in a pocket \emptyset of 18 mm

EW_{max} = Slope angle of the helix (results from G and S_{max})

The specified machining values are guide values.

The optimum data for the respective machining task should be determined during the test or machining.

Cutting data recommendations for shoulder milling cutters

Feed and cutting speed

Part-contact cutting

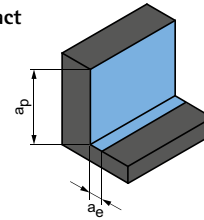

$$a_p = 3xD$$

$$a_e = 0.1xD$$

OptiMill-Alu-HPC-Pocket | SCM854

MMG*	Workpiece material	Strength/hardness [N/mm ²] [HRC]	Cooling			v _c [m/min]	f _z [mm]							
			MQL/Air	Dry	Coolant		Diameter of milling cutter [mm]							
							5.00	8.00	10.00	12.00	14.00	16.00	18.00	20.00
N1	N1.1 Aluminium, non-alloy and alloy < 3 % Si		✓	✓	✓	915	0.061	0.091	0.110	0.126	0.141	0.154	0.166	0.176
	N1.2 Aluminium, alloy ≤ 7 % Si		✓	✓	✓	610	0.064	0.096	0.115	0.132	0.148	0.162	0.174	0.185
	N1.3 Aluminium, alloy > 7-12 % Si		✓	✓	✓	485	0.067	0.101	0.121	0.139	0.155	0.169	0.182	0.193
	N1.4 Aluminium, alloy > 12 % Si		✓	✓	✓	350	0.073	0.110	0.131	0.151	0.169	0.185	0.199	0.211
N2	N2.1 Copper, non-alloy and low-alloy	< 300	✓	✓	✓	350	0.049	0.073	0.088	0.101	0.113	0.123	0.132	0.141
	N2.2 Copper, alloy	> 300	✓	✓	✓	265	0.049	0.073	0.088	0.101	0.113	0.123	0.132	0.141
	N2.3 Brass, bronze, gunmetal	< 1200	✓	✓	✓	440	0.030	0.046	0.055	0.063	0.070	0.077	0.083	0.088
N4	N4.1 Plastic, thermoplastics		✓	✓	✓	120	0.030	0.046	0.055	0.063	0.070	0.077	0.083	0.088
	N4.2 Plastic, thermosets		✓	✓	✓	180	0.030	0.046	0.055	0.063	0.070	0.077	0.083	0.088
	N4.3 Plastic, foams		✓	✓		315	0.018	0.027	0.033	0.038	0.042	0.046	0.050	0.053

OptiMill-Alu-HPC-Pocket | SCM854

MMG*	Workpiece material	Strength/hardness [N/mm ²] [HRC]	Cooling		
			MQL/Air	Dry	Coolant
N1	N1.1 Aluminium, non-alloy and alloy < 3 % Si		✓	✓	✓
	N1.2 Aluminium, alloy ≤ 7 % Si		✓	✓	✓
	N1.3 Aluminium, alloy > 7-12 % Si		✓	✓	✓
	N1.4 Aluminium, alloy > 12 % Si		✓	✓	✓
N2	N2.1 Copper, non-alloy and low-alloy	< 300	✓	✓	✓
	N2.2 Copper, alloy	> 300	✓	✓	✓
	N2.3 Brass, bronze, gunmetal	< 1200	✓	✓	✓
N4	N4.1 Plastic, thermoplastics		✓	✓	✓
	N4.2 Plastic, thermosets		✓	✓	✓
	N4.3 Plastic, foams		✓	✓	

Calculation example for 42CrMo4 ø 12 mm:

$$f_z | a_e | h_m \text{ max.} = \frac{D}{100} \cdot \text{See table for value}$$

N1.1	Aluminium, non-alloy and alloy < 3 % Si	✓	✓	✓	915	0.061	0.091	0.110	0.126	0.141	0.154	0.166	0.176
------	-----------------------------------------	---	---	---	-----	-------	-------	-------	-------	-------	-------	-------	-------

1 $f_z = \frac{12 \text{ mm}}{100} \cdot 1,2 = 0,144 \text{ mm}$

2 $h_m \text{ max.} = \frac{12 \text{ mm}}{100} \cdot 0,84 = 0,101 \text{ mm}$

* MAPAL machining groups

** If the alloy parts Cr, Mo, Ni, V, W in total > 8%, then select the next highest MAPAL machining group.

Full cutting

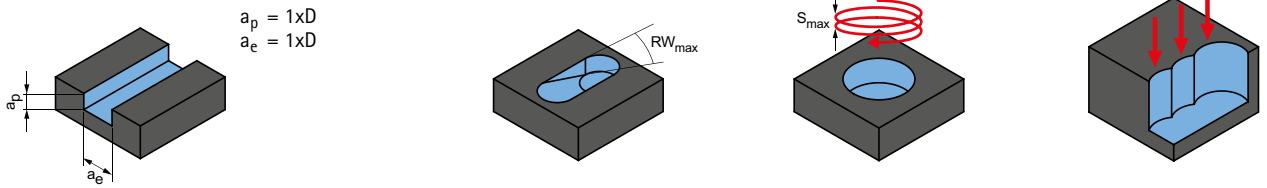

v_c [m/min]	f_z [mm]								Ramps	Helix milling		Grooving	
	Diameter of milling cutter [mm]								RW_{max}	S_{max}	EW_{max}		f_z factor
	5.00	8.00	10.00	12.00	14.00	16.00	18.00	20.00			G = 1.5	G = 1.8	
495	0.045	0.068	0.081	0.093	0.104	0.114	0.123	0.130	45°	0.75xD	25°	16°	0.8
330	0.047	0.071	0.085	0.098	0.109	0.120	0.129	0.137	45°	0.75xD	25°	16°	0.8
265	0.050	0.075	0.089	0.103	0.115	0.125	0.135	0.143	45°	0.75xD	25°	16°	0.8
190	0.054	0.081	0.097	0.112	0.125	0.137	0.147	0.156	45°	0.75xD	25°	16°	0.8
190	0.036	0.054	0.065	0.075	0.083	0.091	0.098	0.104	45°	0.75xD	25°	16°	0.8
145	0.036	0.054	0.065	0.075	0.083	0.091	0.098	0.104	45°	0.75xD	25°	16°	0.8
240	0.023	0.034	0.041	0.047	0.052	0.057	0.061	0.065	45°	0.75xD	25°	16°	0.8
65	0.023	0.034	0.041	0.047	0.052	0.057	0.061	0.065	45°	0.75xD	25°	16°	0.8
100	0.023	0.034	0.041	0.047	0.052	0.057	0.061	0.065	45°	0.75xD	25°	16°	0.8
170	0.014	0.020	0.024	0.028	0.031	0.034	0.037	0.039	45°	0.75xD	25°	16°	0.8

Trochoidal milling

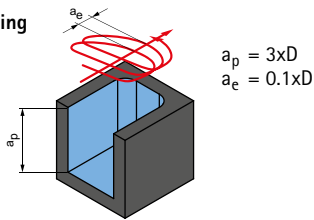

Trochoidal milling

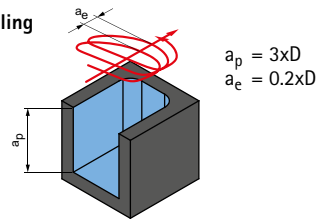

v_c [m/min]	f_z [mm] in % of D	h_{max} [mm] in % of D	v_c [m/min]	f_z [mm] in % of D	h_{max} [mm] in % of D
915	0.1 - 1.4	0.84	810	0.7 - 0.9	1.12
610	0.1 - 1.5	0.90	540	0.7 - 1.0	1.20
485	1.0 - 1.3	0.78	430	0.8 - 1.0	1.04
350	1.1 - 1.5	0.90	310	0.8 - 1.1	1.20
350	0.7 - 1.0	0.60	310	0.5 - 0.8	0.80
265	0.7 - 1.0	0.60	235	0.5 - 0.8	0.80
440	0.4 - 0.6	0.36	390	0.3 - 0.5	0.48
120	0.4 - 0.6	0.36	105	0.3 - 0.5	0.48
180	0.4 - 0.6	0.36	160	0.3 - 0.5	0.48
315	0.3 - 0.4	0.24	280	0.2 - 0.3	0.32

Explanation of terms:

RW_{max} = Maximum angle of the ramp

S_{max} = Maximum slope of the helix

G = Ratio of circular pocket \emptyset when plunging to the tool \emptyset

E.g.: Tool \emptyset 12 mm at G=1.5 results in a pocket \emptyset of 18 mm

EW_{max} = Slope angle of the helix (results from G and S_{max})

Cutting data recommendations for shoulder milling cutters

Feed and cutting speed

Tool length/correction factor:	
Length	f_z & v_c
Short	1
Long	0,9
Overlong	0,8
Extra long	0,6

Full cutting

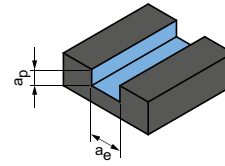

$$a_p = 0.6 \times D$$

$$a_e = 1 \times D$$

OptiMill-Uni-HPC-Silent | SCM570

MMG*	Workpiece material	Strength/hardness [N/mm ²] [HRC]	Cooling			v_c [m/min]	f_z [mm]								
			MQL/Air	Dry	Coolant		Diameter of milling cutter [mm]								
							6.00	8.00	10.00	12.00	16.00	20.00	25.00		
P	P1.1	Structural, free-cutting, case hardened and heat-treated steels, non-alloy	< 700	✓	✓	✓	235	0.045	0.057	0.069	0.079	0.096	0.110	0.123	
	P1.2	Structural, free-cutting, case hardened and heat-treated steels, non-alloy	< 1200	✓	✓	✓	190	0.042	0.053	0.064	0.074	0.090	0.103	0.115	
	P2.1	Nitrided, case hardened and heat-treated steels, alloy	< 900	✓	✓	✓	210	0.045	0.057	0.069	0.079	0.096	0.110	0.123	
	P2.2	Nitrided, case hardened and heat-treated steels, alloy	< 1400	✓	✓	✓	150	0.037	0.048	0.057	0.066	0.080	0.092	0.102	
	P3.1	Tool, bearing, spring and high-speed steels**	< 800	✓	✓	✓	135	0.043	0.055	0.066	0.076	0.093	0.106	0.119	
	P3.2	Tool, bearing, spring and high-speed steels**	< 1000	✓	✓	✓	125	0.041	0.052	0.063	0.072	0.088	0.101	0.113	
	P3.3	Tool, bearing, spring and high-speed steels**	< 1500	✓	✓	✓	115	0.039	0.050	0.059	0.068	0.083	0.095	0.106	
	P4	P4.1	Stainless steels, ferritic and martensitic		✓	✓	✓	95	0.030	0.038	0.046	0.053	0.064	0.073	0.082
P5	P5.1	Cast steel			✓	✓	140	0.043	0.055	0.066	0.076	0.093	0.106	0.119	
P6	P6.1	Stainless cast steel, ferritic and martensitic			✓	✓	95	0.021	0.027	0.032	0.037	0.045	0.051	0.057	
M	M1.1	Stainless steels, austenitic	< 700	✓	✓	✓	65	0.026	0.033	0.040	0.046	0.056	0.064	0.072	
	M1.2	Stainless steels, ferritic/austenitic (duplex)	< 1000			✓	60	0.022	0.028	0.033	0.038	0.046	0.053	0.059	
	M2	M2.1	Stainless/heat-resistant cast steel, austenitic	< 700	✓	✓	✓	70	0.028	0.036	0.043	0.050	0.061	0.070	0.078
	M3	M3.1	Stainless cast steel, ferritic/austenitic (duplex)	< 1000			✓	65	0.022	0.029	0.034	0.039	0.048	0.055	0.061
K	K1	K1.1	Cast iron with lamellar graphite (grey cast iron), GJL	< 300	✓	✓	✓	250	0.075	0.095	0.114	0.131	0.160	0.183	0.205
	K1	K1.2	Cast iron with spheroidal graphite, GJS	< 500	✓	✓	✓	230	0.063	0.081	0.097	0.112	0.136	0.156	0.174
	K2	K2.1	Cast iron with spheroidal graphite, GJS	≤ 800	✓	✓	✓	190	0.052	0.067	0.080	0.092	0.112	0.128	0.143
	K2	K2.2	Cast iron with spheroidal graphite, GJS	> 800	✓	✓	✓	105	0.030	0.038	0.046	0.053	0.064	0.073	0.082
	K3	K3.1	Cast iron with spheroidal graphite, GJV; malleable cast iron, GJM	< 500	✓	✓	✓	170	0.052	0.067	0.080	0.092	0.112	0.128	0.143
	K3	K3.2	Cast iron with spheroidal graphite, GJV; malleable cast iron, GJM	> 500	✓	✓	✓	160	0.045	0.057	0.069	0.079	0.096	0.110	0.123

Groove milling

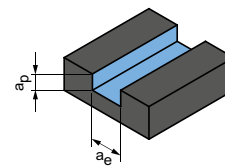

$$a_p = 1 \times D$$

$$a_e = 1 \times D$$

OptiMill-Inox-HPC | SCM108

MMG*	Workpiece material	Strength/hardness [N/mm ²] [HRC]	Cooling			v_c [m/min]	f_z [mm]									
			MQL/Air	Dry	Coolant		Diameter of milling cutter [mm]									
							3.00	4.00	6.00	8.00	10.00	12.00	16.00	20.00		
M	M1.1	Stainless steels, austenitic	< 700	✓	✓	✓	70	0.011	0.013	0.019	0.025	0.030	0.035	0.044	0.051	
	M1.2	Stainless steels, ferritic/austenitic (duplex)	< 1000			✓	65	0.009	0.011	0.016	0.020	0.025	0.029	0.036	0.042	
	M2	M2.1	Stainless/heat-resistant cast steel, austenitic	< 700	✓	✓	✓	75	0.011	0.015	0.021	0.027	0.032	0.038	0.047	0.055
	M3	M3.1	Stainless cast steel, ferritic/austenitic (duplex)	< 1000			✓	70	0.009	0.012	0.016	0.021	0.026	0.030	0.037	0.043

* MAPAL machining groups

** If the alloy parts Cr, Mo, Ni, V, W in total > 8%, then select the next highest MAPAL machining group.

Roughing

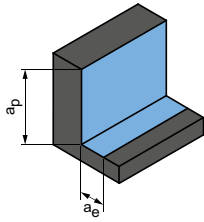

$$a_p = 1.5xD$$

$$a_e = 0.25xD$$

Finishing

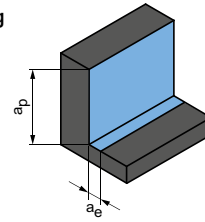

$$a_p = 1.5xD$$

$$a_e = 0.1xD$$

v_c [m/min]	f_z [mm]								v_c [m/min]	f_z [mm]							
	Diameter of milling cutter [mm]									Diameter of milling cutter [mm]							
	6.00	8.00	10.00	12.00	16.00	20.00	25.00	6.00		8.00	10.00	12.00	16.00	20.00	25.00		
355	0.059	0.075	0.090	0.103	0.126	0.145	0.161	480	0.093	0.119	0.142	0.164	0.200	0.228	0.255		
290	0.055	0.070	0.084	0.097	0.118	0.135	0.151	395	0.087	0.111	0.133	0.153	0.187	0.213	0.238		
325	0.059	0.075	0.090	0.103	0.126	0.145	0.161	435	0.093	0.119	0.142	0.164	0.200	0.228	0.255		
225	0.049	0.063	0.075	0.086	0.105	0.120	0.134	305	0.078	0.099	0.119	0.136	0.167	0.190	0.212		
210	0.057	0.073	0.087	0.100	0.122	0.140	0.156	285	0.090	0.115	0.138	0.158	0.193	0.221	0.246		
195	0.054	0.069	0.083	0.095	0.116	0.132	0.148	260	0.085	0.109	0.130	0.150	0.183	0.209	0.234		
180	0.051	0.065	0.078	0.090	0.110	0.125	0.140	240	0.081	0.103	0.123	0.142	0.173	0.198	0.221		
145	0.039	0.050	0.060	0.069	0.084	0.096	0.108	195	0.062	0.079	0.095	0.109	0.133	0.152	0.170		
215	0.057	0.073	0.087	0.100	0.122	0.140	0.156	295	0.090	0.115	0.138	0.158	0.193	0.221	0.246		
145	0.027	0.035	0.042	0.048	0.059	0.067	0.075	195	0.043	0.055	0.066	0.076	0.093	0.107	0.119		
110	0.034	0.044	0.053	0.060	0.074	0.084	0.094	160	0.054	0.069	0.083	0.095	0.117	0.133	0.149		
105	0.028	0.036	0.044	0.050	0.061	0.070	0.078	150	0.045	0.057	0.069	0.079	0.097	0.110	0.123		
120	0.037	0.048	0.057	0.066	0.080	0.092	0.102	180	0.059	0.075	0.090	0.104	0.127	0.145	0.161		
110	0.029	0.038	0.045	0.052	0.063	0.072	0.081	160	0.047	0.059	0.071	0.082	0.100	0.114	0.127		
440	0.098	0.125	0.150	0.172	0.211	0.241	0.269	650	0.155	0.198	0.237	0.273	0.333	0.381	0.425		
405	0.083	0.106	0.128	0.147	0.179	0.205	0.228	595	0.132	0.168	0.202	0.232	0.283	0.324	0.361		
330	0.069	0.088	0.105	0.121	0.147	0.169	0.188	485	0.109	0.139	0.166	0.191	0.233	0.267	0.297		
185	0.039	0.050	0.060	0.069	0.084	0.096	0.108	270	0.062	0.079	0.095	0.109	0.133	0.152	0.170		
295	0.069	0.088	0.105	0.121	0.147	0.169	0.188	430	0.109	0.139	0.166	0.191	0.233	0.267	0.297		
275	0.059	0.075	0.090	0.103	0.126	0.145	0.161	405	0.093	0.119	0.142	0.164	0.200	0.228	0.255		

Roughing

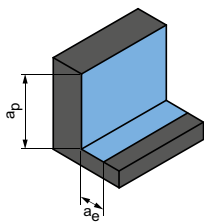

$$a_p = 1.5xD$$

$$a_e = 0.25xD$$

Finishing

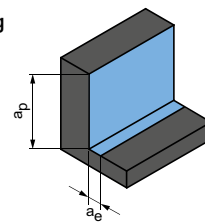

$$a_p = 1.5xD$$

$$a_e = 0.1xD$$

v_c [m/min]	f_z [mm]								v_c [m/min]	f_z [mm]							
	Diameter of milling cutter [mm]									Diameter of milling cutter [mm]							
	3.00	4.00	6.00	8.00	10.00	12.00	16.00	20.00		3.00	4.00	6.00	8.00	10.00	12.00	16.00	20.00
110	0.018	0.023	0.033	0.042	0.051	0.059	0.074	0.086	160	0.028	0.036	0.051	0.066	0.080	0.093	0.117	0.135
105	0.015	0.019	0.027	0.035	0.042	0.049	0.061	0.071	150	0.023	0.030	0.043	0.055	0.066	0.077	0.097	0.112
120	0.019	0.025	0.035	0.045	0.055	0.064	0.080	0.093	180	0.031	0.039	0.056	0.072	0.087	0.101	0.127	0.147
110	0.015	0.020	0.028	0.036	0.043	0.051	0.063	0.073	160	0.024	0.031	0.044	0.057	0.069	0.080	0.100	0.116

The specified machining values are guide values.
The optimum data for the respective machining task should be determined during the test or machining.

Cutting data recommendations for shoulder milling cutters

Feed and cutting speed

OptiMill-Hardened | SCM102, 103

MMG*		Workpiece material	Strength/hardness [N/mm ²] [HRC]	Cooling			
				MQL/Air	Dry	Coolant	
P	P1	P1.1	Structural, free-cutting, case hardened and heat-treated steels, non-alloy	< 700	✓	✓	✓
		P1.2	Structural, free-cutting, case hardened and heat-treated steels, non-alloy	< 1200	✓	✓	✓
	P2	P2.1	Nitrided, case hardened and heat-treated steels, alloy	< 900	✓	✓	✓
		P2.2	Nitrided, case hardened and heat-treated steels, alloy	< 1400	✓	✓	✓
	P3	P3.1	Tool, bearing, spring and high-speed steels**	< 800	✓	✓	✓
		P3.2	Tool, bearing, spring and high-speed steels**	< 1000	✓	✓	✓
		P3.3	Tool, bearing, spring and high-speed steels**	< 1500	✓	✓	✓
	P4	P4.1	Stainless steels, ferritic and martensitic		✓		✓
	P5	P5.1	Cast steel		✓		✓
	P6	P6.1	Stainless cast steel, ferritic and martensitic		✓		✓
H	H1	H1.1	Hardened steel / cast steel	< 44	✓	✓	
		H1.2	Hardened steel / cast steel	< 55	✓	✓	
	H2	H2.1	Hardened steel / cast steel	< 60	✓		

* MAPAL machining groups

** If the alloy parts Cr, Mo, Ni, V, W in total > 8%, then select the next highest MAPAL machining group.

Roughing

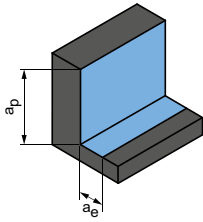

Next page:
Finishing

a_p [mm] in % of D	a_e [mm] in % of D	v_c [m/min]	f_z [mm]								
			Diameter of milling cutter [mm]								
			4.00	5.00	6.00	8.00	10.00	12.00	16.00	20.00	
50	8	180 - 200	0.032	0.040	0.048	0.055	0.075	0.095	0.110	0.140	
50	8	160 - 180	0.030	0.038	0.046	0.052	0.071	0.090	0.105	0.133	
50	8	170 - 190	0.032	0.040	0.048	0.055	0.075	0.095	0.110	0.140	
50	8	150 - 170	0.030	0.038	0.046	0.052	0.071	0.090	0.105	0.133	
50	8	170 - 190	0.032	0.040	0.048	0.055	0.075	0.095	0.110	0.140	
50	7	150 - 170	0.030	0.038	0.046	0.052	0.071	0.090	0.105	0.133	
50	7	130 - 150	0.027	0.034	0.041	0.047	0.064	0.081	0.094	0.119	
50	7	130 - 150	0.027	0.034	0.041	0.047	0.064	0.081	0.094	0.119	
50	7	130 - 150	0.027	0.034	0.041	0.047	0.064	0.081	0.094	0.119	
50	8	140 - 160	0.029	0.036	0.043	0.050	0.068	0.086	0.099	0.126	
50	2	100 - 125	0.027	0.034	0.041	0.047	0.064	0.081	0.094	0.119	
50	1.5	80 - 100	0.022	0.028	0.034	0.039	0.053	0.067	0.077	0.098	
50	1.2	60 - 80	0.019	0.024	0.029	0.033	0.045	0.057	0.066	0.084	

The specified machining values are guide values.
The optimum data for the respective machining task should be determined during the test or machining.

Cutting data recommendations for shoulder milling cutters

Feed and cutting speed

OptiMill-Hardened | SCM102, 103

MMG*		Workpiece material	Strength/hardness [N/mm ²] [HRC]	Cooling			
				MQL/Air	Dry	Coolant	
P	P1	P1.1	Structural, free-cutting, case hardened and heat-treated steels, non-alloy	< 700	✓	✓	✓
		P1.2	Structural, free-cutting, case hardened and heat-treated steels, non-alloy	< 1200	✓	✓	✓
	P2	P2.1	Nitrided, case hardened and heat-treated steels, alloy	< 900	✓	✓	✓
		P2.2	Nitrided, case hardened and heat-treated steels, alloy	< 1400	✓	✓	✓
	P3	P3.1	Tool, bearing, spring and high-speed steels**	< 800	✓	✓	✓
		P3.2	Tool, bearing, spring and high-speed steels**	< 1000	✓	✓	✓
		P3.3	Tool, bearing, spring and high-speed steels**	< 1500	✓	✓	✓
	P4	P4.1	Stainless steels, ferritic and martensitic		✓		✓
	P5	P5.1	Cast steel		✓		✓
	P6	P6.1	Stainless cast steel, ferritic and martensitic		✓		✓
M	M1	M1.1	Stainless steels, austenitic	< 700			✓
		M1.2	Stainless steels, ferritic/austenitic (duplex)	< 1000			✓
	M2	M2.1	Stainless/heat-resistant cast steel, austenitic	< 700			✓
	M3	M3.1	Stainless cast steel, ferritic/austenitic (duplex)	< 1000			✓
K	K1	K1.1	Cast iron with lamellar graphite (grey cast iron), GJL	< 300	✓	✓	✓
		K2.1	Cast iron with spheroidal graphite, GJS	< 500	✓	✓	✓
		K2.2	Cast iron with spheroidal graphite, GJS	≤ 800	✓	✓	✓
	K3	K2.3	Cast iron with spheroidal graphite, GJS	> 800	✓	✓	✓
		K3.1	Cast iron with spheroidal graphite, GJV; malleable cast iron, GJM	< 500	✓	✓	✓
		K3.2	Cast iron with spheroidal graphite, GJV; malleable cast iron, GJM	> 500	✓	✓	✓
H	H1	H1.1	Hardened steel / cast steel	< 44	✓	✓	
		H1.2	Hardened steel / cast steel	< 55	✓	✓	
	H2	H2.1	Hardened steel / cast steel	< 60	✓		

* MAPAL machining groups

** If the alloy parts Cr, Mo, Ni, V, W in total > 8%, then select the next highest MAPAL machining group.

Finishing

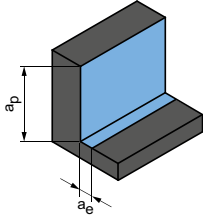

	a_p [mm] in % of D	a_e [mm] in % of D	v_c [m/min]	f_z [mm]							
				Diameter of milling cutter [mm]							
				4.00	5.00	6.00	8.00	10.00	12.00	16.00	20.00
	100	2	200 - 220	0.025	0.030	0.040	0.050	0.065	0.075	0.090	0.105
	100	2	180 - 200	0.024	0.029	0.038	0.048	0.062	0.071	0.086	0.100
	100	2	180 - 200	0.025	0.030	0.040	0.050	0.065	0.075	0.090	0.105
	100	2	160 - 180	0.024	0.029	0.038	0.048	0.062	0.071	0.086	0.100
	100	2	180 - 200	0.025	0.030	0.040	0.050	0.065	0.075	0.090	0.105
	100	2	160 - 180	0.024	0.029	0.038	0.048	0.062	0.071	0.086	0.100
	100	2	140 - 160	0.021	0.026	0.034	0.043	0.055	0.064	0.077	0.089
	100	2	140 - 160	0.021	0.026	0.034	0.043	0.055	0.064	0.077	0.089
	100	2	140 - 160	0.021	0.026	0.034	0.043	0.055	0.064	0.077	0.089
	100	2	150 - 170	0.023	0.027	0.036	0.045	0.059	0.068	0.081	0.095
	100	1.5	110 - 130	0.023	0.027	0.036	0.045	0.059	0.068	0.081	0.095
	100	1.5	90 - 110	0.021	0.026	0.034	0.043	0.055	0.064	0.077	0.089
	100	1.5	110 - 130	0.023	0.027	0.036	0.045	0.059	0.068	0.081	0.095
	100	1.5	90 - 130	0.021	0.026	0.034	0.043	0.055	0.064	0.077	0.089
	100	2.5	200 - 220	0.025	0.030	0.040	0.050	0.065	0.075	0.090	0.105
	100	2.5	180 - 200	0.024	0.029	0.038	0.048	0.062	0.071	0.086	0.100
	100	2.5	180 - 200	0.024	0.029	0.038	0.048	0.062	0.071	0.086	0.100
	100	2.5	170 - 190	0.023	0.027	0.036	0.045	0.059	0.068	0.081	0.095
	100	2.5	200 - 220	0.025	0.030	0.040	0.050	0.065	0.075	0.090	0.105
	100	2.5	180 - 200	0.024	0.029	0.038	0.048	0.062	0.071	0.086	0.100
	100	1.5	110 - 130	0.021	0.026	0.034	0.043	0.055	0.064	0.077	0.089
	100	1.2	90 - 115	0.018	0.021	0.028	0.035	0.046	0.053	0.063	0.074
	100	0.8	70 - 90	0.015	0.018	0.024	0.030	0.039	0.045	0.054	0.063

The specified machining values are guide values.

The optimum data for the respective machining task should be determined during the test or machining.

Cutting data recommendations for shoulder milling cutters

Feed and cutting speed

Tool length/correction factor:	
Length	f_z & v_c
Short	1
Long	0,9
Overlong	0,8
Extra long	0,6

Groove milling

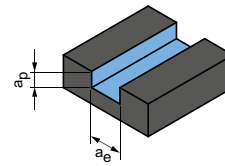

$$a_p = 1 \times D$$

$$a_e = 1 \times D$$

OptiMill-Alu-HPC | SCM270

MMG*	Workpiece material	Strength/hardness [N/mm ²] [HRC]	Cooling			v_c [m/min]	f_z [mm]								
			MQL/Air	Dry	Coolant		Diameter of milling cutter [mm]								
							2.00	4.00	6.00	8.00	10.00	12.00	16.00	20.00	
N	N1	N1.1 Aluminium, non-alloy and alloy < 3 % Si	✓	✓	✓	765	0.021	0.041	0.059	0.075	0.090	0.104	0.127	0.145	
		N1.2 Aluminium, alloy ≤ 7 % Si	✓	✓	✓	510	0.023	0.043	0.062	0.079	0.095	0.109	0.133	0.152	
		N1.3 Aluminium, alloy > 7-12 % Si	✓	✓	✓	405	0.024	0.045	0.065	0.083	0.099	0.114	0.139	0.159	
		N1.4 Aluminium, alloy > 12 % Si	✓	✓	✓	295	0.026	0.049	0.071	0.090	0.108	0.124	0.152	0.174	
	N2	N2.1 Copper, non-alloy and low-alloy	< 300	✓	✓	✓	295	0.017	0.033	0.047	0.060	0.072	0.083	0.101	0.116
		N2.2 Copper, alloy	> 300	✓	✓	✓	220	0.017	0.033	0.047	0.060	0.072	0.083	0.101	0.116
		N2.3 Brass, bronze, gunmetal	< 1200	✓	✓	✓	365	0.011	0.020	0.029	0.038	0.045	0.052	0.063	0.072
	N4	N4.1 Plastic, thermoplastics		✓	✓	✓	100	0.011	0.020	0.029	0.038	0.045	0.052	0.063	0.072
		N4.2 Plastic, thermosets		✓	✓	✓	150	0.011	0.020	0.029	0.038	0.045	0.052	0.063	0.072
		N4.3 Plastic, foams		✓	✓		265	0.006	0.012	0.018	0.023	0.027	0.031	0.038	0.043

OptiMill-Mono-Alu | SCM281

MMG*	Workpiece material	Strength/hardness [N/mm ²] [HRC]	Cooling			v_c [m/min]	f_z [mm]							
			MQL/Air	Dry	Coolant		Diameter of milling cutter [mm]							
							2.00	3.00	4.00	5.00	6.00	8.00	12.00	
N	N1	N1.1 Aluminium, non-alloy and alloy < 3 % Si	✓	✓	✓	765	0.043	0.063	0.082	0.100	0.118	0.151	0.207	
		N1.2 Aluminium, alloy ≤ 7 % Si	✓	✓	✓	510	0.045	0.066	0.086	0.105	0.124	0.158	0.218	
		N1.3 Aluminium, alloy > 7-12 % Si	✓	✓	✓	405	0.047	0.069	0.090	0.110	0.130	0.166	0.228	
		N1.4 Aluminium, alloy > 12 % Si	✓	✓	✓	295	0.051	0.075	0.098	0.120	0.141	0.181	0.249	
	N2	N2.1 Copper, non-alloy and low-alloy	< 300	✓	✓	✓	295	0.034	0.050	0.066	0.080	0.094	0.120	0.166
		N2.2 Copper, alloy	> 300	✓	✓	✓	220	0.034	0.050	0.066	0.080	0.094	0.120	0.166
		N2.3 Brass, bronze, gunmetal	< 1200	✓	✓	✓	365	0.021	0.031	0.041	0.050	0.059	0.075	0.104
	N4	N4.1 Plastic, thermoplastics		✓	✓	✓	100	0.021	0.031	0.041	0.050	0.059	0.075	0.104
		N4.2 Plastic, thermosets		✓	✓	✓	150	0.021	0.031	0.041	0.050	0.059	0.075	0.104
		N4.3 Plastic, foams		✓	✓		265	0.013	0.019	0.025	0.030	0.035	0.045	0.062

* MAPAL machining groups

** If the alloy parts Cr, Mo, Ni, V, W in total > 8%, then select the next highest MAPAL machining group.

Roughing

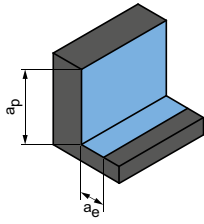

$$a_p = 1.5xD$$

$$a_e = 0.25xD$$

Finishing

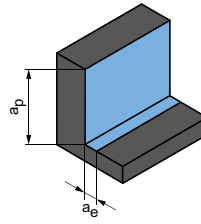

$$a_p = 1.5xD$$

$$a_e = 0.1xD$$

v_c [m/min]	f_z [mm]								v_c [m/min]	f_z [mm]							
	Diameter of milling cutter [mm]									Diameter of milling cutter [mm]							
	2.00	4.00	6.00	8.00	10.00	12.00	16.00	20.00		2.00	4.00	6.00	8.00	10.00	12.00	16.00	20.00
1,180	0.030	0.057	0.082	0.105	0.126	0.145	0.177	0.202	1,410	0.042	0.080	0.115	0.147	0.176	0.202	0.246	0.282
785	0.032	0.060	0.087	0.111	0.132	0.152	0.186	0.213	940	0.044	0.084	0.120	0.154	0.184	0.212	0.259	0.296
625	0.033	0.063	0.091	0.116	0.139	0.159	0.195	0.223	750	0.046	0.088	0.126	0.161	0.193	0.222	0.271	0.310
450	0.036	0.069	0.099	0.126	0.151	0.174	0.212	0.243	540	0.050	0.096	0.138	0.176	0.211	0.242	0.296	0.338
450	0.024	0.046	0.066	0.084	0.101	0.116	0.142	0.162	540	0.033	0.064	0.092	0.117	0.140	0.161	0.197	0.225
340	0.024	0.046	0.066	0.084	0.101	0.116	0.142	0.162	405	0.033	0.064	0.092	0.117	0.140	0.161	0.197	0.225
565	0.015	0.029	0.041	0.053	0.063	0.072	0.089	0.101	675	0.021	0.040	0.057	0.073	0.088	0.101	0.123	0.141
155	0.015	0.029	0.041	0.053	0.063	0.072	0.089	0.101	185	0.021	0.040	0.057	0.073	0.088	0.101	0.123	0.141
230	0.015	0.029	0.041	0.053	0.063	0.072	0.089	0.101	275	0.021	0.040	0.057	0.073	0.088	0.101	0.123	0.141
405	0.009	0.017	0.025	0.032	0.038	0.043	0.053	0.061	485	0.013	0.024	0.034	0.044	0.053	0.061	0.074	0.085

v_c [m/min]	f_z [mm]							v_c [m/min]	f_z [mm]						
	Diameter of milling cutter [mm]								Diameter of milling cutter [mm]						
	2.00	3.00	4.00	5.00	6.00	8.00	12.00		2.00	3.00	4.00	5.00	6.00	8.00	12.00
1,180	0.060	0.088	0.115	0.140	0.165	0.211	0.290	1,410	0.084	0.122	0.160	0.195	0.229	0.293	0.403
785	0.063	0.092	0.120	0.147	0.173	0.221	0.304	940	0.088	0.129	0.168	0.205	0.241	0.308	0.424
625	0.066	0.097	0.126	0.154	0.181	0.232	0.319	750	0.092	0.135	0.176	0.215	0.252	0.322	0.444
450	0.072	0.106	0.138	0.168	0.198	0.253	0.348	540	0.100	0.147	0.192	0.234	0.275	0.352	0.484
450	0.048	0.070	0.092	0.112	0.132	0.168	0.232	540	0.067	0.098	0.128	0.156	0.184	0.234	0.323
340	0.048	0.070	0.092	0.112	0.132	0.168	0.232	405	0.067	0.098	0.128	0.156	0.184	0.234	0.323
565	0.030	0.044	0.057	0.070	0.082	0.105	0.145	675	0.042	0.061	0.080	0.098	0.115	0.147	0.202
155	0.030	0.044	0.057	0.070	0.082	0.105	0.145	185	0.042	0.061	0.080	0.098	0.115	0.147	0.202
230	0.030	0.044	0.057	0.070	0.082	0.105	0.145	275	0.042	0.061	0.080	0.098	0.115	0.147	0.202
405	0.018	0.026	0.034	0.042	0.049	0.063	0.087	485	0.025	0.037	0.048	0.059	0.069	0.088	0.121

The specified machining values are guide values.
The optimum data for the respective machining task should be determined during the test or machining.

Cutting data recommendations for shoulder milling cutters

Feed and cutting speed

Tool length/correction factor:	
Length	f_z & v_c
Short	1
long	0,9

OptiMill-SPM | SCM681, 691

MMG*	Workpiece material	Strength/hardness [N/mm ²] [HRC]	Cooling		
			MQL/Air	Dry	Coolant
N N1	N1.1 Aluminium, non-alloy and alloy < 3 % Si		✓	✓	✓
	N1.2 Aluminium, alloy ≤ 7 % Si		✓	✓	✓
	N1.3 Aluminium, alloy > 7-12 % Si		✓	✓	✓
	N1.4 Aluminium, alloy > 12 % Si		✓	✓	✓

OptiMill-Diamond-SPM | SHM101, 110, 111

MMG*	Workpiece material	Strength/hardness [N/mm ²] [HRC]	Cooling		
			MQL/Air	Dry	Coolant
N N1	N1.1 Aluminium, non-alloy and alloy < 3 % Si		✓	✓	✓
	N1.2 Aluminium, alloy ≤ 7 % Si		✓	✓	✓
	N1.3 Aluminium, alloy > 7-12 % Si		✓	✓	✓
	N1.4 Aluminium, alloy > 12 % Si		✓	✓	✓

OptiMill-Diamond-SPM, HSK (hollow shank taper) design | SHM121

MMG*	Workpiece material	Strength/hardness [N/mm ²] [HRC]	Cooling		
			MQL/Air	Dry	Coolant
N N1	N1.1 Aluminium, non-alloy and alloy < 3 % Si		✓	✓	✓
	N1.2 Aluminium, alloy ≤ 7 % Si		✓	✓	✓
	N1.3 Aluminium, alloy > 7-12 % Si		✓	✓	✓
	N1.4 Aluminium, alloy > 12 % Si		✓	✓	✓

Groove milling

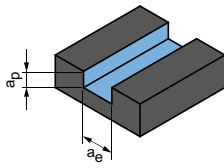

$a_p = 0.5 \times D$
 $a_e = 1 \times D$

Groove milling

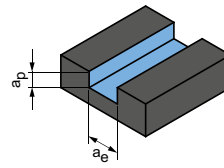

$a_p = 0.3 \times D$
 $a_e = 1 \times D$

v_c [m/min]	f_z [mm]								v_c [m/min]	f_z [mm]							
	Diameter of milling cutter [mm]									Diameter of milling cutter [mm]							
	6.00	8.00	10.00	12.00	16.00	20.00	25.00	32.00		6.00	8.00	10.00	12.00	16.00	20.00	25.00	32.00
1,990	0.111	0.142	0.170	0.196	0.239	0.273	0.305	0.332	1,990	0.128	0.164	0.196	0.225	0.275	0.315	0.351	0.383
1,320	0.117	0.149	0.179	0.206	0.251	0.287	0.320	0.349	1,320	0.135	0.172	0.206	0.237	0.289	0.331	0.369	0.402
1,055	0.122	0.156	0.187	0.215	0.263	0.301	0.336	0.366	1,055	0.141	0.180	0.216	0.248	0.303	0.346	0.387	0.421
760	0.134	0.171	0.204	0.235	0.287	0.328	0.366	0.399	760	0.154	0.197	0.235	0.271	0.331	0.378	0.422	0.459

Diameter of milling cutter [mm]								Diameter of milling cutter [mm]							
6.00 - 8.00		10.00 - 12.00		16.00 - 20.00		25.00 - 32.00		6.00 - 8.00		10.00 - 12.00		16.00 - 20.00		25.00 - 32.00	
v_c [m/min]	f_z [mm]	v_c [m/min]	f_z [mm]	v_c [m/min]	f_z [mm]	v_c [m/min]	f_z [mm]	v_c [m/min]	f_z [mm]	v_c [m/min]	f_z [mm]	v_c [m/min]	f_z [mm]	v_c [m/min]	f_z [mm]
max. 300	0.10-0.12	max. 600	0.12-0.20	max. 900	0.20-0.30	max. 1,500	0.20-0.30	max. 300	0.12-0.15	max. 600	0.15-0.25	max. 900	0.25-0.33	max. 1,500	0.25-0.33
max. 300	0.10-0.12	max. 600	0.12-0.20	max. 900	0.20-0.30	max. 1,500	0.20-0.30	max. 300	0.12-0.15	max. 600	0.15-0.25	max. 900	0.25-0.33	max. 1,500	0.25-0.33
max. 300	0.10-0.12	max. 600	0.12-0.20	max. 900	0.20-0.30	max. 1,500	0.20-0.30	max. 300	0.12-0.15	max. 600	0.15-0.25	max. 900	0.25-0.33	max. 1,500	0.25-0.33
< 300	0.09-0.11	< 600	0.10-0.18	< 900	0.18-0.25	< 1,200	0.18-0.25	< 300	0.10-0.12	< 600	0.12-0.20	< 900	0.20-0.30	< 1,200	0.20-0.30

Diameter of milling cutter [mm]						Diameter of milling cutter [mm]					
32.00		40.00		50.00		32.00		40.00		50.00	
v_c [m/min]	f_z [mm]	v_c [m/min]	f_z [mm]	v_c [m/min]	f_z [mm]	v_c [m/min]	f_z [mm]	v_c [m/min]	f_z [mm]	v_c [m/min]	f_z [mm]
1,500	0.15-0.25	1,800	0.20-0.30	1,800	0.20-0.30	1,500	0.20-0.33	1,800	0.25-0.33	1,800	0.25-0.33
1,500	0.15-0.25	1,800	0.20-0.30	1,800	0.20-0.30	1,500	0.20-0.33	1,800	0.25-0.33	1,800	0.25-0.33
1,500	0.15-0.25	1,800	0.20-0.30	1,800	0.20-0.30	1,500	0.20-0.33	1,800	0.25-0.33	1,800	0.25-0.33
< 1,500	0.12-0.20	< 1,800	0.18-0.25	< 1,800	0.18-0.25	< 1,500	0.15-0.25	< 1,800	0.20-0.30	< 1,800	0.22-0.30

The specified machining values are guide values.
The optimum data for the respective machining task should be determined during the test or machining.

Cutting data recommendations for shoulder milling cutters

Feed and cutting speed

OptiMill-Diamond type 51 | SHM511, 611, 711
 OptiMill-Diamond type 50 | SHM500
 OptiMill-Diamond type 53 | SHM531
 OptiMill-Diamond type 57 | SHM571

Groove milling

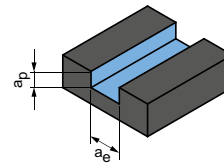

$$a_p = 0.5 \times D$$

$$a_e = 1 \times D$$

MMG*		Workpiece material	Strength/hardness [N/mm ²] [HRC]	Cooling			Diameter of milling cutter [mm]							
				MQL/Air	Dry	Coolant	3.00 - 6.00		8.00 - 10.00		12.00 - 16.00		18.00 - 25.00	
							v _c [m/min]	f _z [mm]	v _c [m/min]	f _z [mm]	v _c [m/min]	f _z [mm]	v _c [m/min]	f _z [mm]
N	N1	N1.1 Aluminium, non-alloy and alloy < 3 % Si		✓	✓	✓	200	0.10-0.12	500	0.12-0.15	800	0.15-0.20	1,000	0.18-0.23
		N1.2 Aluminium, alloy ≤ 7 % Si		✓	✓	✓	200	0.10-0.12	500	0.12-0.15	800	0.15-0.20	1,000	0.18-0.23
		N1.3 Aluminium, alloy > 7-12 % Si		✓	✓	✓	200	0.10-0.12	500	0.12-0.15	800	0.15-0.20	1,000	0.18-0.23
		N1.4 Aluminium, alloy > 12 % Si		✓	✓	✓	200	0.10-0.12	500	0.12-0.15	800	0.15-0.20	1,000	0.18-0.23
	N2	N2.1 Copper, non-alloy and low-alloy	< 300	✓	✓	✓	200	0.10-0.12	500	0.12-0.15	800	0.15-0.20	1,000	0.18-0.23
		N2.2 Copper, alloy	> 300	✓	✓	✓	200	0.10-0.12	500	0.12-0.15	800	0.15-0.20	1,000	0.18-0.23
		N2.3 Brass, bronze, gunmetal	< 1200	✓	✓	✓	200	0.10-0.12	500	0.12-0.15	800	0.15-0.20	1,000	0.18-0.23
	N4	N4.1 Plastic, thermoplastics												
		N4.2 Plastic, thermosets		✓	✓	✓	200	0.10-0.12	500	0.12-0.15	800	0.15-0.20	1,000	0.18-0.23
		N4.3 Plastic, foams												
C	C1.1 Plastic matrix, aramide fibre-reinforced (AFRP)													
	C1.2 Plastic matrix (thermosetting), CFRP/GFRP		✓	✓	✓	200	0.10-0.12	500	0.12-0.15	800	0.15-0.20	1,000	0.18-0.23	
	C1.3 Plastic matrix (thermoplastic), CFRP/GFRP		✓	✓	✓	200	0.10-0.12	500	0.12-0.15	800	0.15-0.20	1,000	0.18-0.23	
	C2.1 Carbon matrix, carbon fibre-reinforced (CFC)		✓	✓	✓	200	0.10-0.12	500	0.12-0.15	800	0.15-0.20	1,000	0.18-0.23	

* MAPAL machining groups

Roughing

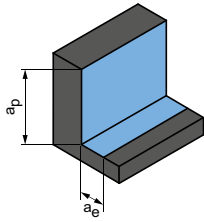

$$a_p = 0.5xD$$

$$a_e = 0.25xD$$

Finishing

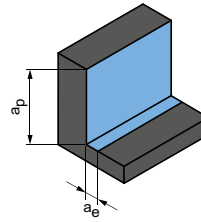

$$a_p = 0.5xD$$

$$a_e = 0.1xD$$

		Diameter of milling cutter [mm]								Diameter of milling cutter [mm]							
		3.00 - 6.00		8.00 - 10.00		12.00 - 16.00		18.00 - 25.00		3.00 - 6.00		8.00 - 10.00		12.00 - 16.00		18.00 - 25.00	
v_c [m/min]	f_z [mm]	v_c [m/min]	f_z [mm]	v_c [m/min]	f_z [mm]	v_c [m/min]	f_z [mm]	v_c [m/min]	f_z [mm]	v_c [m/min]	f_z [mm]	v_c [m/min]	f_z [mm]	v_c [m/min]	f_z [mm]	v_c [m/min]	f_z [mm]
240	0.10-0.12	480	0.12-0.16	720	0.16-0.20	960	0.16-0.22	300	0.12-0.15	600	0.15-0.20	900	0.20-0.25	1,200	0.20-0.27		
240	0.10-0.12	480	0.12-0.16	720	0.16-0.20	960	0.16-0.22	300	0.12-0.15	600	0.15-0.20	900	0.20-0.25	1,200	0.20-0.27		
240	0.10-0.12	480	0.12-0.16	720	0.16-0.20	960	0.16-0.22	300	0.12-0.15	600	0.15-0.20	900	0.20-0.25	1,200	0.20-0.27		
240	0.10-0.12	480	0.12-0.16	720	0.16-0.20	960	0.16-0.22	300	0.12-0.15	600	0.15-0.20	900	0.20-0.25	1,200	0.20-0.27		
240	0.10-0.12	480	0.12-0.16	720	0.16-0.20	960	0.16-0.22	300	0.12-0.15	600	0.15-0.20	900	0.20-0.25	1,200	0.20-0.27		
240	0.10-0.12	480	0.12-0.16	720	0.16-0.20	960	0.16-0.22	300	0.12-0.15	600	0.15-0.20	900	0.20-0.25	1,200	0.20-0.27		
240	0.10-0.12	480	0.12-0.16	720	0.16-0.20	960	0.16-0.22	300	0.12-0.15	600	0.15-0.20	900	0.20-0.25	1,200	0.20-0.27		
240	0.10-0.12	480	0.12-0.16	720	0.16-0.20	960	0.16-0.22	300	0.12-0.15	600	0.15-0.20	900	0.20-0.25	1,200	0.20-0.27		
240	0.10-0.12	480	0.12-0.16	720	0.16-0.20	960	0.16-0.22	300	0.12-0.15	600	0.15-0.20	900	0.20-0.25	1,200	0.20-0.27		
240	0.10-0.12	480	0.12-0.16	720	0.16-0.20	960	0.16-0.22	300	0.12-0.15	600	0.15-0.20	900	0.20-0.25	1,200	0.20-0.27		
240	0.10-0.12	480	0.12-0.16	720	0.16-0.20	960	0.16-0.22	300	0.12-0.15	600	0.15-0.20	900	0.20-0.25	1,200	0.20-0.27		

The specified machining values are guide values.
The optimum data for the respective machining task should be determined during the test or machining.

Cutting data recommendations for shoulder milling cutters

Feed and cutting speed

Tool length/correction factor:	
Length	f_z & v_c
Short	1
Long	0,9
Overlong	0,8
Extra long	0,6

OptiMill-Diamond type 57, with HSK-A
(hollow shank taper form A) connection | SHM571

MMG*	Workpiece material	Strength/hardness [N/mm ²] [HRC]	Cooling		
			MQL/Air	Dry	Coolant
N N1	N1.1 Aluminium, non-alloy and alloy < 3 % Si		✓	✓	✓
	N1.2 Aluminium, alloy ≤ 7 % Si		✓	✓	✓
	N1.3 Aluminium, alloy > 7-12 % Si		✓	✓	✓
	N1.4 Aluminium, alloy > 12 % Si		✓	✓	✓

Application examples

Full cutting



$a_p = 100\%$
 $a_e = 100\%$



Part-contact cutting



$a_p = 100\%$
 $a_e = 100\%$

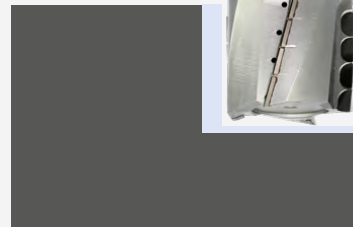

Comment:

The OptiMill-Diamond type 57, design with HSK-A (hollow shank taper form A) connection, is a milling cutter for trimming. It is not suitable for full slot milling with max. a_p and a_e .

Trimming

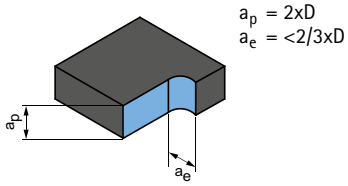

		Diameter of milling cutter [mm]							
		32.00		40.00		50.00		63.00	
v_c [m/min]	f_z [mm]	v_c [m/min]	f_z [mm]	v_c [m/min]	f_z [mm]	v_c [m/min]	f_z [mm]	v_c [m/min]	f_z [mm]
1,200	0.15 - 0.25	1,500	0.20 - 0.30	1,800	0.20 - 0.30	1,800	0.20 - 0.30	1,800	0.20 - 0.30
1,200	0.15 - 0.25	1,500	0.20 - 0.30	1,800	0.20 - 0.30	1,800	0.20 - 0.30	1,800	0.20 - 0.30
1,200	0.15 - 0.25	1,500	0.20 - 0.30	1,800	0.20 - 0.30	1,800	0.20 - 0.30	1,800	0.20 - 0.30
< 1,200	0.12 - 0.20	< 1,500	0.18 - 0.25	< 1,800	0.18 - 0.25	< 1,800	0.18 - 0.25	< 1,800	0.18 - 0.25

Trimming



$a_p = < 100\%$
 $a_e = \text{max. } 2/3xD$

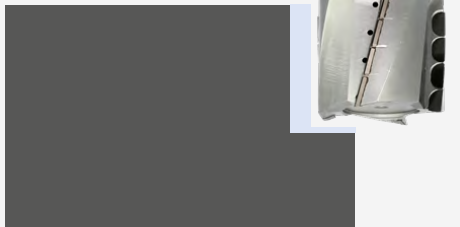

Groove milling



$a_p = 1/3 \text{ SKL}$
 $a_e = 100\%$



Cutting data recommendations for shoulder milling cutters

Feed and cutting speed

Groove milling

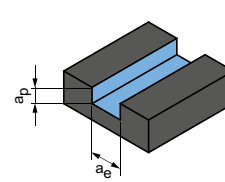

$$a_p = 1 \times D$$

$$a_e = 1 \times D$$

OptiMill-Composite-Speed-Plus, uncoated | SCM982, 992

MMG*	Workpiece material	Strength/hardness [N/mm ²] [HRC]	Cooling			v _c [m/min]	f _z [mm]								
			MQL/Air	Dry	Coolant		Diameter of milling cutter [mm]								
							4.00	6.00	8.00	10.00	12.00	16.00	20.00		
N N4	N4.1	Plastic, thermoplastics	✓	✓	✓	125									
	N4.2	Plastic, thermosets	✓	✓	✓		0.020	0.029	0.038	0.045	0.052	0.063	0.072		
	N4.3	Plastic, foams	✓	✓											
C	C1	C1.1	Plastic matrix, aramide fibre-reinforced (AFRP)	✓	✓	✓	120	0.021	0.026	0.031	0.035	0.038	0.042	0.043	
		C1.2	Plastic matrix (thermosetting), CFRP/GFRP	✓	✓	✓		80	0.021	0.026	0.031	0.035	0.038	0.042	0.043
		C1.3	Plastic matrix (thermoplastic), CFRP/GFRP	✓	✓	✓		120	0.018	0.023	0.027	0.031	0.033	0.037	0.038
	C2	C2.1	Carbon matrix, carbon fibre-reinforced (CFC)	✓	✓	✓	165	0.012	0.015	0.017	0.019	0.021	0.023	0.024	
		C4	C4.1	Sandwich construction, honeycomb core	✓	✓			0.019	0.024	0.028	0.032	0.035	0.039	0.041
			C4.2	Sandwich construction, foam core	✓	✓									

OptiMill-Composite-Speed-Plus, coated | SCM980, 990

MMG*	Workpiece material	Strength/hardness [N/mm ²] [HRC]	Cooling			v _c [m/min]	f _z [mm]								
			MQL/Air	Dry	Coolant		Diameter of milling cutter [mm]								
							4.00	6.00	8.00	10.00	12.00	16.00	20.00		
C	C1	C1.1	Plastic matrix, aramide fibre-reinforced (AFRP)	✓	✓	✓	145	0.021	0.026	0.031	0.035	0.038	0.042	0.043	
		C1.2	Plastic matrix (thermosetting), CFRP/GFRP	✓	✓	✓		100	0.021	0.026	0.031	0.035	0.038	0.042	0.043
		C1.3	Plastic matrix (thermoplastic), CFRP/GFRP	✓	✓	✓		145	0.018	0.023	0.027	0.031	0.033	0.037	0.038
	C2	C2.1	Carbon matrix, carbon fibre-reinforced (CFC)	✓	✓	✓	195	0.012	0.015	0.017	0.019	0.021	0.023	0.024	
		C4	C4.1	Sandwich construction, honeycomb core	✓	✓			0.019	0.024	0.028	0.032	0.035	0.039	0.041
			C4.2	Sandwich construction, foam core	✓	✓									

OptiMill-Composite-Micro | SCM560

MMG*	Workpiece material	Strength/hardness [N/mm ²] [HRC]	v _c [m/min]	f _z [mm]										
				Diameter of milling cutter [mm]										
				2.00	4.00	6.00	8.00	10.00	12.00	16.00	20.00			
N N4	N4.1	Plastic, thermoplastics	105											
	N4.2	Plastic, thermosets		0.005	0.008	0.011								
	N4.3	Plastic, foams												
C	C1	C1.1	Plastic matrix, aramide fibre-reinforced (AFRP)	105	0.005	0.008	0.011							
		C1.2	Plastic matrix (thermosetting), CFRP/GFRP		70	0.005	0.008	0.011						
		C1.3	Plastic matrix (thermoplastic), CFRP/GFRP		145	0.012	0.018	0.023						
	C2	C2.1	Carbon matrix, carbon fibre-reinforced (CFC)	195	0.008	0.012	0.015							
		C4	C4.1		Sandwich construction, honeycomb core	150	0.010	0.019	0.024					
			C4.2		Sandwich construction, foam core									

Roughing

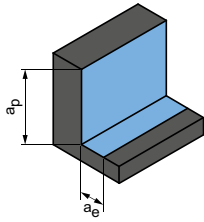

$$a_p = 1.5xD$$

$$a_e = 0.25xD$$

Finishing

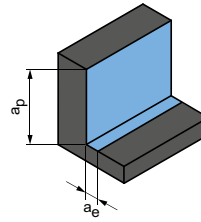

$$a_p = 1.5xD$$

$$a_e = 0.1xD$$

	v_c [m/min]	f_z [mm]							v_c [m/min]	f_z [mm]						
		Diameter of milling cutter [mm]								Diameter of milling cutter [mm]						
		4.00	6.00	8.00	10.00	12.00	16.00	20.00		4.00	6.00	8.00	10.00	12.00	16.00	20.00
190	0.029	0.041	0.053	0.063	0.072	0.089	0.101	230	0.040	0.057	0.073	0.088	0.101	0.123	0.141	
200	0.021	0.026	0.031	0.035	0.038	0.042	0.043	295	0.021	0.026	0.031	0.035	0.038	0.042	0.043	
135	0.021	0.026	0.031	0.035	0.038	0.042	0.043	195	0.021	0.026	0.031	0.035	0.038	0.042	0.043	
200	0.018	0.023	0.027	0.031	0.033	0.037	0.038	295	0.018	0.023	0.027	0.031	0.033	0.037	0.038	
270	0.012	0.015	0.017	0.019	0.021	0.023	0.024	395	0.012	0.015	0.017	0.019	0.021	0.023	0.024	
200	0.019	0.024	0.028	0.032	0.035	0.039	0.041	300	0.019	0.024	0.028	0.032	0.035	0.039	0.041	

	v_c [m/min]	f_z [mm]							v_c [m/min]	f_z [mm]						
		Diameter of milling cutter [mm]								Diameter of milling cutter [mm]						
		4.00	6.00	8.00	10.00	12.00	16.00	20.00		4.00	6.00	8.00	10.00	12.00	16.00	20.00
240	0.021	0.026	0.031	0.035	0.038	0.042	0.043	355	0.021	0.026	0.031	0.035	0.038	0.042	0.043	
160	0.021	0.026	0.031	0.035	0.038	0.042	0.043	235	0.021	0.026	0.031	0.035	0.038	0.042	0.043	
240	0.018	0.023	0.027	0.031	0.033	0.037	0.038	355	0.018	0.023	0.027	0.031	0.033	0.037	0.038	
325	0.012	0.015	0.017	0.019	0.021	0.023	0.024	480	0.012	0.015	0.017	0.019	0.021	0.023	0.024	
245	0.019	0.024	0.028	0.032	0.035	0.039	0.041	360	0.019	0.024	0.028	0.032	0.035	0.039	0.041	

	v_c [m/min]	f_z [mm]							v_c [m/min]	f_z [mm]						
		Diameter of milling cutter [mm]								Diameter of milling cutter [mm]						
		2.00	4.00	6.00	8.00	10.00	12.00	16.00		20.00	2.00	4.00	6.00	8.00	10.00	12.00
210	0.008	0.013	0.018					310	0.012	0.02	0.028					
210	0.008	0.013	0.018					310	0.012	0.02	0.028					
140	0.008	0.013	0.018					210	0.012	0.02	0.028					
240	0.012	0.018	0.023					355	0.012	0.018	0.023					
325	0.008	0.012	0.015					480	0.008	0.012	0.015					
245	0.010	0.019	0.024					360	0.010	0.019	0.024					

The specified machining values are guide values.
The optimum data for the respective machining task should be determined during the test or machining.

Cutting data recommendations for shoulder milling cutters

Feed and cutting speed

Groove milling

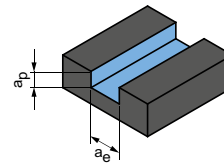

$$a_p = 1 \times D$$

$$a_e = 1 \times D$$

OptiMill-Composite-TwinCut | SCM490

MMG*	Workpiece material	Strength/hardness [N/mm ²] [HRC]	v _c [m/min]	f _z [mm]							
				Diameter of milling cutter [mm]							
				2.00	4.00	6.00	8.00	10.00	12.00	16.00	20.00
C C1	C1.1	Plastic matrix, aramide fibre-reinforced (AFRP)	110	0.015	0.027	0.038	0.049	0.06	0.07	0.087	0.101
	C1.2	Plastic matrix (thermosetting), CFRP/GFRP									
	C1.3	Plastic matrix (thermoplastic), CFRP/GFRP									

OptiMill-Thermoplastic-FR | SCM610

MMG*	Workpiece material	Strength/hardness [N/mm ²] [HRC]	v _c [m/min]	f _z [mm]							
				Diameter of milling cutter [mm]							
				2.00	4.00	6.00	8.00	10.00	12.00	16.00	20.00
N N4	N4.1	Plastic, thermoplastics	100	0.011	0.019	0.027	0.035	0.043	0.05	0.062	0.072
	N4.2	Plastic, thermosets									
	N4.3	Plastic, foams									
C C1	C1.1	Plastic matrix, aramide fibre-reinforced (AFRP)	100	0.011	0.019	0.027	0.035	0.043	0.05	0.062	0.072
	C1.2	Plastic matrix (thermosetting), CFRP/GFRP									
	C1.3	Plastic matrix (thermoplastic), CFRP/GFRP									

OptiMill-Mono-Plastic | SCM330

MMG*	Workpiece material	Strength/hardness [N/mm ²] [HRC]	v _c [m/min]	f _z [mm]							
				Diameter of milling cutter [mm]							
				2.00	4.00	6.00	8.00	10.00	12.00	16.00	20.00
N N4	N4.1	Plastic, thermoplastics	100	0.022	0.03	0.028	0.047	0.055	0.07	0.085	0.1
	N4.2	Plastic, thermosets	150	0.022	0.03	0.028	0.047	0.055	0.07	0.085	0.1
	N4.3	Plastic, foams									

* MAPAL machining groups

Roughing

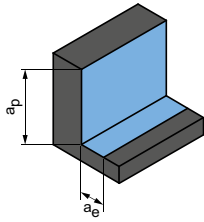

$$a_p = 1.5 \times D$$

$$a_e = 0.25 \times D$$

Finishing

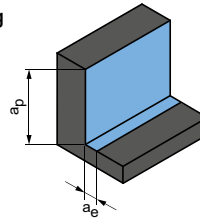

$$a_p = 1.5 \times D$$

$$a_e = 0.1 \times D$$

v_c [m/min]	f_z [mm]									v_c [m/min]	f_z [mm]								
	Diameter of milling cutter [mm]										Diameter of milling cutter [mm]								
	2.00	4.00	6.00	8.00	10.00	12.00	16.00	20.00	2.00		4.00	6.00	8.00	10.00	12.00	16.00	20.00		
220	0.026	0.046	0.065	0.084	0.101	0.118	0.148	0.171	325	0.041	0.072	0.103	0.132	0.16	0.187	0.234	0.271		

v_c [m/min]	f_z [mm]									v_c [m/min]	f_z [mm]								
	Diameter of milling cutter [mm]										Diameter of milling cutter [mm]								
	2.00	4.00	6.00	8.00	10.00	12.00	16.00	20.00	2.00		4.00	6.00	8.00	10.00	12.00	16.00	20.00		
200	0.018	0.033	0.046	0.06	0.072	0.084	0.106	0.122	295	0.029	0.052	0.073	0.094	0.115	0.133	0.167	0.194		

v_c [m/min]	f_z [mm]									v_c [m/min]	f_z [mm]								
	Diameter of milling cutter [mm]										Diameter of milling cutter [mm]								
	2.00	4.00	6.00	8.00	10.00	12.00	16.00	20.00	2.00		4.00	6.00	8.00	10.00	12.00	16.00	20.00		
200	0.037	0.051	0.065	0.079	0.093	0.119	0.145	0.169	295	0.058	0.081	0.103	0.125	0.147	0.189	0.229	0.267		
300	0.037	0.051	0.065	0.079	0.093	0.119	0.145	0.169	445	0.058	0.081	0.103	0.125	0.147	0.189	0.229	0.267		

The specified machining values are guide values.
The optimum data for the respective machining task should be determined during the test or machining.





SHOULDER MILLING CUTTER – ROUGHING

Universal application

OptiMill-Uni-HPC-Rough	108
OptiMill-Uni-Wave	110
ECU-Mill-Uni-Rough&Finish CPMill-Uni-Rough&Finish	120

Non-ferrous metals

OptiMill-SPM-Rough	118
--------------------	-----

Technical appendix

Cutting data recommendations	122
------------------------------	-----

OptiMill®-Uni-HPC-Rough

Shoulder milling cutter, short design with neck
SCM700

Design:

Diameter of milling cutter: 5.00 – 20.00 mm
Cutting material: HP213
Number of cutting edges: 3 to ø 8 mm
4 from ø 9 mm

Helix angle: 30°

Special features: Unequal spacing, profile undercut HPC roughing teeth

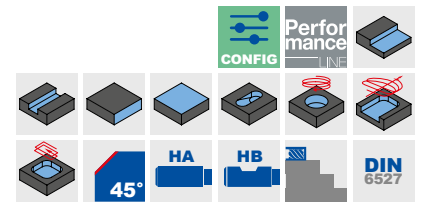
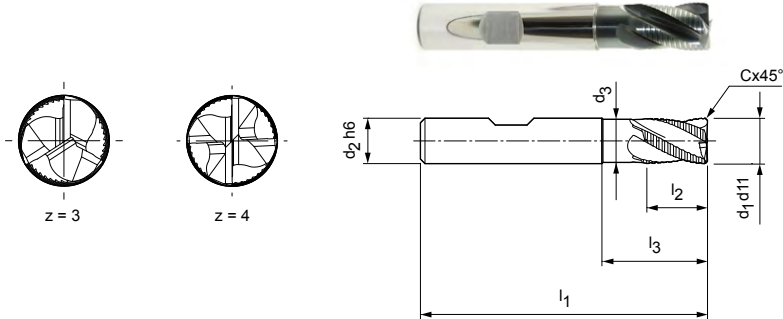

Preferred series in stock

Dimensions							z	Specification	Order no.
d ₁ d ₁₁	d ₂ h ₆	d ₃	l ₁	l ₂	l ₃	Cx45°			
*5,00	6	–	54	8	–	0,30	3	SCM700-0500Z03R-F0030HB-HP213	30653380
6,00	6	5,5	54	8	18	0,30	3	SCM700-0600Z03R-F0030HB-HP213	30653381
*7,00	8	–	58	11	–	0,30	3	SCM700-0700Z03R-F0030HB-HP213	30653382
8,00	8	7,5	58	11	22	0,30	3	SCM700-0800Z03R-F0030HB-HP213	30653383
*9,00	10	–	66	13	–	0,50	4	SCM700-0900Z04R-F0050HB-HP213	30653384
10,00	10	9,5	66	13	26	0,50	4	SCM700-1000Z04R-F0050HB-HP213	30653385
12,00	12	11	73	16	28	0,50	4	SCM700-1200Z04R-F0050HB-HP213	30653386
14,00	14	13	76	16	31	0,50	4	SCM700-1400Z04R-F0050HB-HP213	30653387
16,00	16	15	82	19	34	0,50	4	SCM700-1600Z04R-F0050HB-HP213	30653388
18,00	18	17	84	19	36	0,50	4	SCM700-1800Z04R-F0050HB-HP213	30653389
20,00	20	19	92	20	42	0,50	4	SCM700-2000Z04R-F0050HB-HP213	30653390

Configurable features



Shank form:
Shank form: HA



Specification:
SCM700-0500Z03R-F0030[shank form]-HP213

Example:

SCM700-0500Z03R-F0030HA-HP213

Shank form HA

Dimensions in mm.

* Design without neck.

For cutting data recommendations, see end of chapter.

Special designs and other coatings available upon request.

OptiMill®-Uni-HPC-Rough

Shoulder milling cutter, long design with neck
SCM710

Design:

Diameter of milling cutter: 4.00 – 25.00 mm
Cutting material: HP213
Number of cutting edges: 3 to ø 8 mm
4 from ø 9 mm
5 from ø 25 mm

Helix angle: 30°

Special features: Unequal spacing, profile undercut HPC roughing teeth

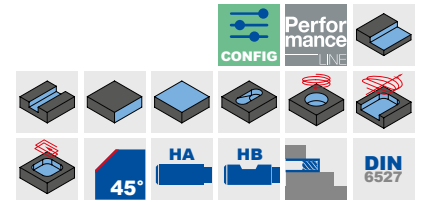
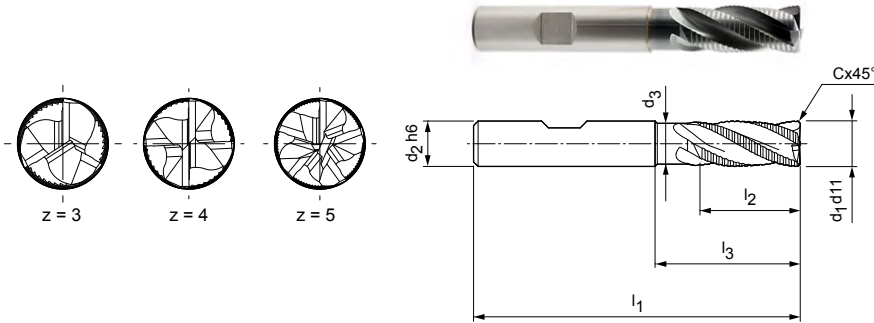

Preferred series in stock

Dimensions							z	Specification	Order no.
d ₁ d ₁₁	d ₂ h ₆	d ₃ h ₉	l ₁	l ₂	l ₃	Cx45°			
*4,00	6	–	57	8	–	0,30	3	SCM710-0400Z03R-F0030HB-HP213	30653391
*5,00	6	–	57	13	–	0,30	3	SCM710-0500Z03R-F0030HB-HP213	30653392
6,00	6	5,5	57	13	21	0,30	3	SCM710-0600Z03R-F0030HB-HP213	30653393
*7,00	8	–	63	16	–	0,30	3	SCM710-0700Z03R-F0030HB-HP213	30653394
8,00	8	7,5	63	16	26	0,30	3	SCM710-0800Z03R-F0030HB-HP213	30653395
*9,00	10	–	72	19	–	0,50	4	SCM710-0900Z04R-F0050HB-HP213	30653396
10,00	10	9,5	72	22	32	0,50	4	SCM710-1000Z04R-F0050HB-HP213	30653397
*11,00	12	–	83	26	–	0,50	4	SCM710-1100Z04R-F0050HB-HP213	30653398
12,00	12	11	83	26	38	0,50	4	SCM710-1200Z04R-F0050HB-HP213	30653399
*13,00	14	–	83	26	–	0,50	4	SCM710-1300Z04R-F0050HB-HP213	30653400
14,00	14	13	83	26	42	0,50	4	SCM710-1400Z04R-F0050HB-HP213	30653401
16,00	16	15	92	32	44	0,50	4	SCM710-1600Z04R-F0050HB-HP213	30653402
18,00	18	17	92	32	48	0,50	4	SCM710-1800Z04R-F0050HB-HP213	30653403
20,00	20	19	104	38	54	0,50	4	SCM710-2000Z04R-F0050HB-HP213	30653405
25,00	25	24	121	45	65	0,50	5	SCM710-2500Z05R-F0050HB-HP213	30673093

Configurable features



Shank form:
Shank form: HA



Specification:
SCM710-0400Z03R-F0030[shank form]-HP213

Example:

SCM710-0400Z03R-F0030HA-HP213

Shank form HA

Dimensions in mm.

* Design without neck.

For cutting data recommendations, see end of chapter.

Special designs and other coatings available upon request.

OptiMill®-Uni-Wave

Shoulder milling cutter, short design
SCM890

Design:

Diameter of milling cutter: 4.00 - 25.00 mm
Cutting material: HP723
Number of cutting edges: 5
Helix angle: ~ 41.5°
Special features: Unequal spacing, newly developed roughing profile

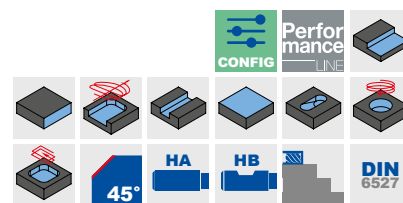
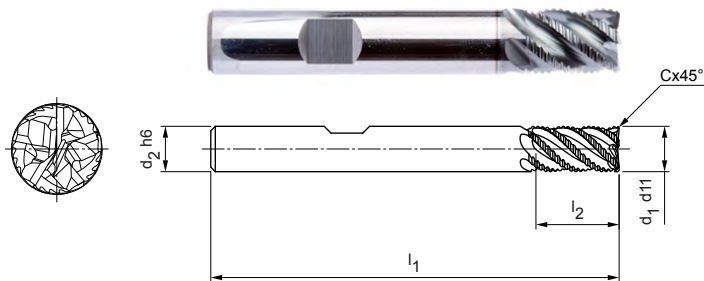

Preferred series in stock

Dimensions					z	Specification	Order no.
d ₁ d ₁₁	d ₂ h ₆	l ₁	l ₂	Cx45°			
4,00	6	54	8	0,20	5	SCM890-0400Z05R-F0020HB-HP723	30917921
5,00	6	54	9	0,25	5	SCM890-0500Z05R-F0025HB-HP723	30917923
6,00	6	54	10	0,30	5	SCM890-0600Z05R-F0030HB-HP723	30917924
7,00	8	58	11	0,35	5	SCM890-0700Z05R-F0035HB-HP723	30917925
8,00	8	58	12	0,40	5	SCM890-0800Z05R-F0040HB-HP723	30917926
9,00	10	66	13	0,45	5	SCM890-0900Z05R-F0045HB-HP723	30917927
10,00	10	66	14	0,50	5	SCM890-1000Z05R-F0050HB-HP723	30917928
12,00	12	73	16	0,60	5	SCM890-1200Z05R-F0060HB-HP723	30917929
14,00	14	75	18	0,70	5	SCM890-1400Z05R-F0070HB-HP723	30917930
16,00	16	82	22	0,80	5	SCM890-1600Z05R-F0080HB-HP723	30917931
20,00	20	92	26	1,00	5	SCM890-2000Z05R-F0100HB-HP723	30917933
25,00	25	105	32	1,25	5	SCM890-2500Z05R-F0125HB-HP723	30917934

Available on request

18,00	18	84	24	0,9	5	SCM890-1800Z05R-F0090HB-HP723	30917932
-------	----	----	----	-----	---	-------------------------------	----------

Configurable features



Shank form:
Shank form: HA



Specification:
SCM890-0400Z05R-F0020[shank form]-HP723

Example:

SCM890-0400Z05R-F0020**HA**-HP723

Shank form HA

Dimensions in mm.

For cutting data recommendations, see end of chapter.

Special designs and other coatings available upon request.

OptiMill®-Uni-Wave

Shoulder milling cutter, long design with neck
SCM880

Design:

Diameter of milling cutter: 4.00 - 25.00 mm
Cutting material: HP723
Number of cutting edges: 5
Helix angle: ~ 41.5°
Special features: Unequal spacing, newly developed roughing profile

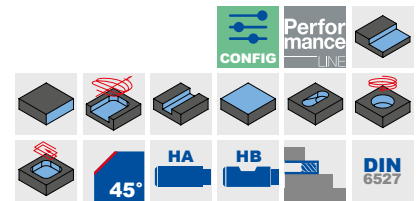
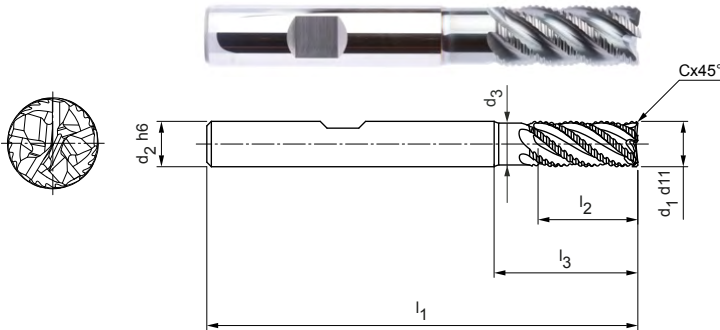

Preferred series in stock

Dimensions							z	Specification	Order no.
d1 d11	d2 h6	d3	l1	l2	l3	Cx45°			
4,00	6	3,7	57	11	19	0,20	5	SCM880-0400Z05R-F0020HB-HP723	30917935
5,00	6	4,6	57	13	19	0,25	5	SCM880-0500Z05R-F0025HB-HP723	30917936
6,00	6	5,6	57	13	19	0,30	5	SCM880-0600Z05R-F0030HB-HP723	30917937
7,00	8	6,5	63	16	25	0,35	5	SCM880-0700Z05R-F0035HB-HP723	30917938
8,00	8	7,4	63	19	25	0,40	5	SCM880-0800Z05R-F0040HB-HP723	30917939
9,00	10	8,3	72	19	30	0,45	5	SCM880-0900Z05R-F0045HB-HP723	30917940
10,00	10	9,3	72	22	30	0,50	5	SCM880-1000Z05R-F0050HB-HP723	30917941
12,00	12	11,1	83	26	36	0,60	5	SCM880-1200Z05R-F0060HB-HP723	30917942
14,00	14	13	83	26	36	0,70	5	SCM880-1400Z05R-F0070HB-HP723	30917943
16,00	16	14,8	92	32	42	0,80	5	SCM880-1600Z05R-F0080HB-HP723	30917944
20,00	20	18,5	104	38	52	1,00	5	SCM880-2000Z05R-F0100HB-HP723	30917946
25,00	25	23,1	125	50	65	1,25	5	SCM880-2500Z05R-F0125HB-HP723	30917947

Available on request

18,00	18	16,7	92	32	42	0,9	5	SCM880-1800Z05R-F0090HB-HP723	30917945
-------	----	------	----	----	----	-----	---	-------------------------------	----------

Configurable features

Shank form:
Shank form: HA

Specification:
SCM880-0400Z05R-F0020[shank form]-HP723

Example:

SCM880-0400Z05R-F0020HA-HP723

Shank form HA

Dimensions in mm.

For cutting data recommendations, see end of chapter.

Special designs and other coatings available upon request.

OptiMill®-Uni-Wave

Shoulder milling cutter, long design with neck, with internal coolant supply
SCM881

Design:

Diameter of milling cutter: 4.00 - 20.00 mm
Cutting material: HP920
Number of cutting edges: 5
Helix angle: ~ 41°
Special features: Unequal spacing, newly developed roughing profile

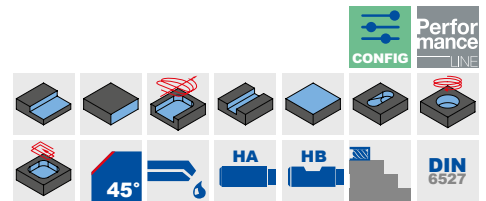
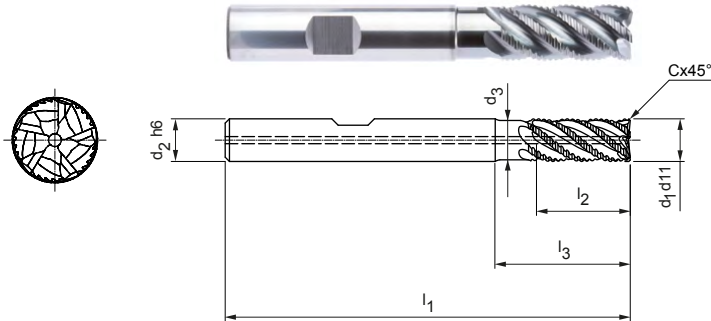

Preferred series in stock

Dimensions							z	Specification	Order no.
d1 d11	d2 h6	d3	l1	l2	l3	Cx45°			
4,00	6	3,7	57	11	19	0,20	5	SCM881-0400Z05R-F0020HB-HP920	31102736
5,00	6	4,6	57	13	19	0,25	5	SCM881-0500Z05R-F0025HB-HP920	31102737
6,00	6	5,6	57	13	19	0,30	5	SCM881-0600Z05R-F0030HB-HP920	31102738
8,00	8	7,4	63	19	25	0,40	5	SCM881-0800Z05R-F0040HB-HP920	31102750
10,00	10	9,3	72	22	30	0,50	5	SCM881-1000Z05R-F0050HB-HP920	31102752
12,00	12	11,1	83	26	36	0,60	5	SCM881-1200Z05R-F0060HB-HP920	31102753
16,00	16	14,8	92	32	42	0,80	5	SCM881-1600Z05R-F0080HB-HP920	31102755
20,00	20	18,5	104	38	52	1,00	5	SCM881-2000Z05R-F0100HB-HP920	31102756

Available on request

14,00	14	13	83	26	36	0,70	5	SCM881-1400Z05R-F0070HB-HP920	31102754
-------	----	----	----	----	----	------	---	-------------------------------	----------

Configurable features



Shank form:
Shank form: HA



Specification:
SCM881-0400Z05R-F0020[shank form]-HP920

Example:

SCM881-0400Z05R-F0020HA-HP920

Shank form HA

Dimensions in mm.

For cutting data recommendations, see end of chapter.

Special designs and other coatings available upon request.

OptiMill®-Uni-Wave

Shoulder milling cutter, design 3xD with neck
SCM900

Design:

Diameter of milling cutter: 5.00 - 25.00 mm
Cutting material: HP723
Number of cutting edges: 5
Helix angle: ~ 42°
Special features: Unequal spacing,
newly developed
roughing profile

Application:

Suitable for shoulder milling up to a maximum cutting width of 0.25xD. Also suitable for trochoidal milling.

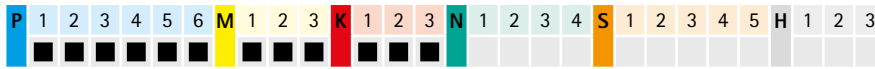
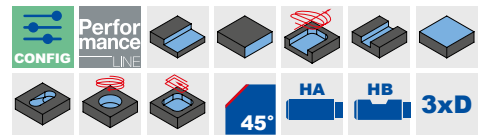
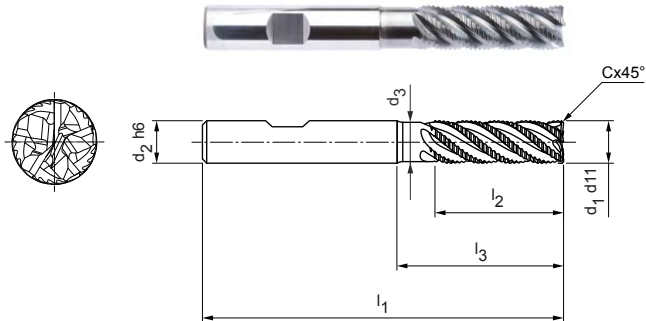

Preferred series in stock

Dimensions							z	Specification	Order no.
d ₁ d ₁₁	d ₂ h ₆	d ₃	l ₁	l ₂	l ₃	Cx45°			
5,00	6	4,6	62	17	24	0,25	5	SCM900-0500Z05R-F0025HB3-HP723	31054554
6,00	6	5,6	62	18	25	0,30	5	SCM900-0600Z05R-F0030HB3-HP723	31054555
8,00	8	7,7	68	24	30	0,40	5	SCM900-0800Z05R-F0040HB3-HP723	31054556
10,00	10	9,3	80	30	35	0,50	5	SCM900-1000Z05R-F0050HB3-HP723	31054557
12,00	12	11,1	93	36	45	0,60	5	SCM900-1200Z05R-F0060HB3-HP723	31054558
14,00	14	13	99	42	50	0,70	5	SCM900-1400Z05R-F0070HB3-HP723	31054559
16,00	16	14,8	108	48	55	0,80	5	SCM900-1600Z05R-F0080HB3-HP723	31054570
20,00	20	18,5	126	60	70	1,00	5	SCM900-2000Z05R-F0100HB3-HP723	31054572

Available on request

18,00	18	16,7	117	54	67	0,90	5	SCM900-1800Z05R-F0090HB3-HP723	31054571
25,00	25	21,1	150	75	92	1,25	5	SCM900-2500Z05R-F0125HB3-HP723	31054573

Configurable features

Shank form:
Shank form: HA

Specification:
SCM900-0500Z05R-F0025[shank form]3-HP723

Example:

SCM900-0500Z05R-F0025HA3-HP723

Shank form HA

Dimensions in mm.

For cutting data recommendations, see end of chapter.

Special designs and other coatings available upon request.

OptiMill®-Uni-Wave

Shoulder milling cutter, 4xD design
SCM900

Design:

Diameter of milling cutter: 6.00 - 20.00 mm
Cutting material: HP723
Number of cutting edges: 5
Helix angle: 38°
Special features: Unequal spacing, newly developed roughing profile

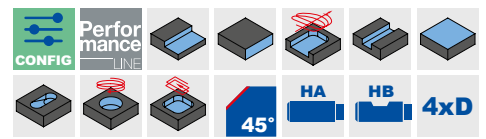
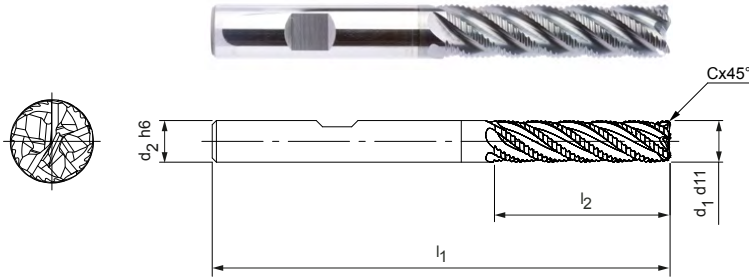

Preferred series in stock

Dimensions					z	Specification	Order no.
d ₁ d ₁₁	d ₂ h ₆	l ₁	l ₂	Cx45°			
6,00	6	66	24	0,30	5	SCM900-0600Z05R-F0030HB4-HP723	31200325
8,00	8	74	32	0,40	5	SCM900-0800Z05R-F0040HB4-HP723	31200326
10,00	10	89	40	0,50	5	SCM900-1000Z05R-F0050HB4-HP723	31200327
12,00	12	100	48	0,60	5	SCM900-1200Z05R-F0060HB4-HP723	31200328
16,00	16	123	64	0,80	5	SCM900-1600Z05R-F0080HB4-HP723	31200329
20,00	20	140	80	1,00	5	SCM900-2000Z05R-F0100HB4-HP723	31200330

Configurable features

Shank form:
Shank form: HA

Specification:
SCM900-0600Z05R-F0030[shank form]4-HP723

Example:

SCM900-0600Z05R-F0030HA4-HP723

Shank form HA

Dimensions in mm.

For cutting data recommendations, see end of chapter.

Special designs and other coatings available upon request.

OptiMill®-Uni-Wave

Shoulder milling cutter, 5xD design
SCM900

Design:

Diameter of milling cutter: 6.00 - 20.00 mm
Cutting material: HP723
Number of cutting edges: 5
Helix angle: 35°
Special features: Unequal spacing, newly developed roughing profile

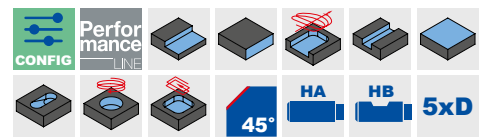
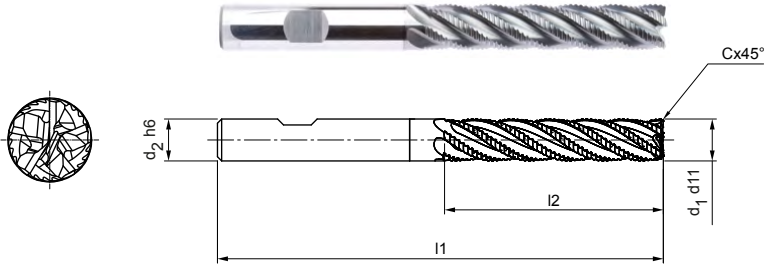

Preferred series in stock

Dimensions					z	Specification	Order no.
d ₁ d ₁₁	d ₂ h ₆	l ₁	l ₂	Cx45°			
6,00	6	69	30	0,30	5	SCM900-0600Z05R-F0030HB5-HP723	31240648
8,00	8	81	40	0,40	5	SCM900-0800Z05R-F0040HB5-HP723	31240649
10,00	10	96	50	0,50	5	SCM900-1000Z05R-F0050HB5-HP723	31240670
12,00	12	112	60	0,60	5	SCM900-1200Z05R-F0060HB5-HP723	31240671
16,00	16	136	80	0,80	5	SCM900-1600Z05R-F0080HB5-HP723	31240672
20,00	20	160	100	1,00	5	SCM900-2000Z05R-F0100HB5-HP723	31240673

Configurable features

Shank form:
Shank form: HA

Specification:
SCM900-0600Z05R-F0030[shank form]5-HP723

Example:

SCM900-0600Z05R-F0030HA5-HP723

Shank form HA

Dimensions in mm.

For cutting data recommendations, see end of chapter.

Special designs and other coatings available upon request.

OptiMill®-Uni-Wave

Shoulder milling cutter, overlong design with neck
SCM900

Design:

Diameter of milling cutter: 5.00 - 25.00 mm
Cutting material: HP210
Number of cutting edges: 5
Helix angle: ~ 41.5°
Special features: Unequal spacing, newly developed roughing profile

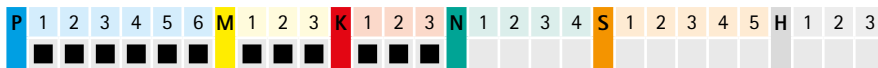
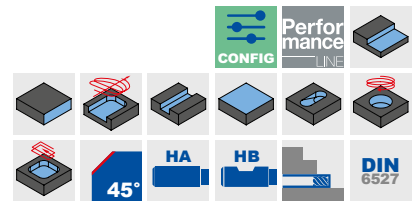
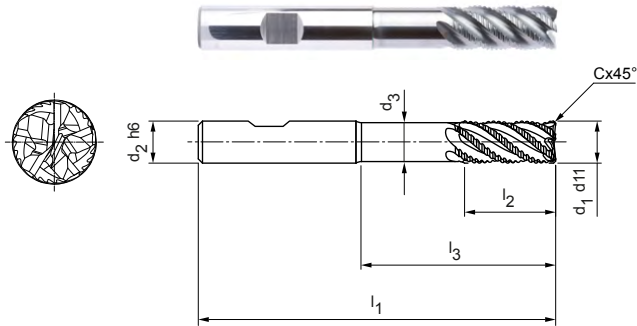

Preferred series in stock

Dimensions							z	Specification	Order no.
d ₁ d ₁₁	d ₂ h ₆	d ₃	l ₁	l ₂	l ₃	Cx45°			
5,00	6	4,6	62	13	24	0,25	5	SCM900-0500Z05R-F0025HB-HP210	31054574
6,00	6	5,6	62	13	25	0,30	5	SCM900-0600Z05R-F0030HB-HP210	31054575
8,00	8	7,4	68	21	30	0,40	5	SCM900-0800Z05R-F0040HB-HP210	31054576
10,00	10	9,3	80	22	38	0,50	5	SCM900-1000Z05R-F0050HB-HP210	31054577
12,00	12	11,1	93	26	46	0,60	5	SCM900-1200Z05R-F0060HB-HP210	31054578
14,00	14	13	99	26	52	0,70	5	SCM900-1400Z05R-F0070HB-HP210	31054579
16,00	16	14,8	108	36	58	0,80	5	SCM900-1600Z05R-F0080HB-HP210	31054580
20,00	20	18,5	126	41	74	1,00	5	SCM900-2000Z05R-F0100HB-HP210	31054582

Available on request

18,00	18	16,7	117	36	67	0,90	5	SCM900-1800Z05R-F0090HB-HP210	31054581
25,00	25	23,1	150	50	92	1,25	5	SCM900-2500Z05R-F0125HB-HP210	31054583

Configurable features



Shank form:
Shank form: HA



Specification:
SCM900-0500Z05R-F0025[shank form]-HP210

Example:

SCM900-0500Z05R-F0025HA-HP210

Shank form HA

Dimensions in mm.

For cutting data recommendations, see end of chapter.

Special designs and other coatings available upon request.

OptiMill®-Uni-Wave

Shoulder milling cutter, extra long design with neck
SCM910

Design:

Diameter of milling cutter: 6.00 - 20.00 mm
Cutting material: HP723
Number of cutting edges: 5
Helix angle: ~ 42°
Special features: Unequal spacing, newly developed roughing profile

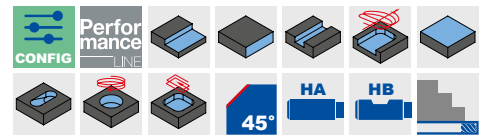
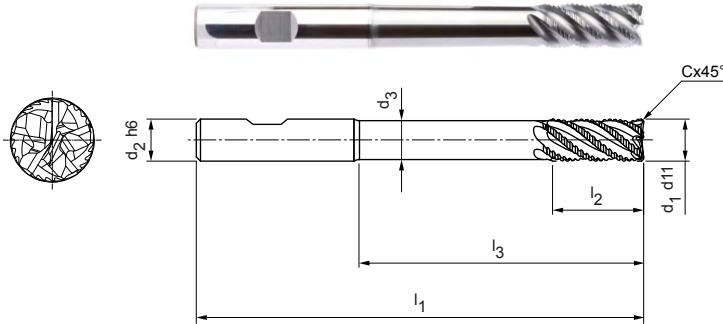

Preferred series in stock

Dimensions							z	Specification	Order no.
d1 d11	d2 h6	d3	l1	l2	l3	Cx45°			
6,00	6	5,4	80	13	42	0,30	5	SCM910-0600Z05R-F0030HB-HP723	31096360
8,00	8	7,2	100	21	62	0,40	5	SCM910-0800Z05R-F0040HB-HP723	31096362
10,00	10	9	100	22	58	0,50	5	SCM910-1000Z05R-F0050HB-HP723	31096363
12,00	12	10,8	120	26	73	0,60	5	SCM910-1200Z05R-F0060HB-HP723	31096364
16,00	16	14,4	150	36	100	0,80	5	SCM910-1600Z05R-F0080HB-HP723	31096365
20,00	20	18	150	41	98	1,00	5	SCM910-2000Z05R-F0100HB-HP723	31096366

Configurable features



Shank form:
Shank form: HA



Specification:
SCM910-0600Z05R-F0030[shank form]-HP723

Example:

SCM910-0600Z05R-F0030HA-HP723

_____ Shank form HA

Dimensions in mm.

For cutting data recommendations, see end of chapter.

Special designs and other coatings available upon request.

OptiMill®-SPM-Rough

Shoulder milling cutter, design with internal coolant supply
SCM951/961

Design:

Diameter of milling cutter: 12.00 - 25.00 mm
Cutting material: HU318
Number of cutting edges: 3
Helix angle: 43°

Application:

High volume machining of structural parts made of aluminium. For full performance of the Opti-Mill-SPM-Rough, it is recommended to use it on high performance machines from 50 kW.

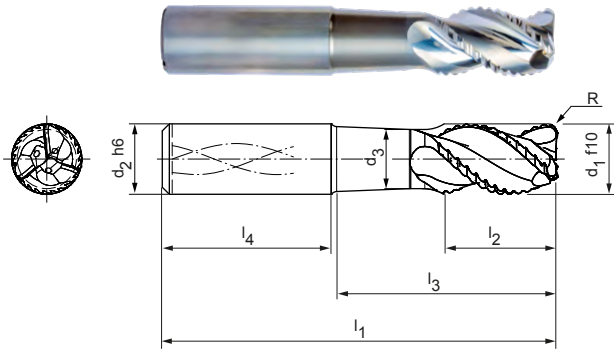

N	1.1	1.2	1.3	1.4	2.1	2.2	2.3	3.1	3.2	4.1	4.2	4.3	C	1.1	1.2	1.3	2.1	3.1	4.1	4.2	5.1	5.2	5.3
---	-----	-----	-----	-----	-----	-----	-----	-----	-----	-----	-----	-----	---	-----	-----	-----	-----	-----	-----	-----	-----	-----	-----

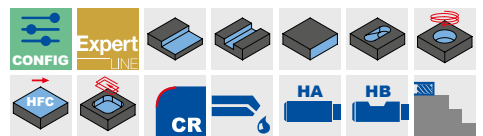

Metric dimensions | Preferred series in stock

Dimensions								z	Specification	Order no.
d1 f10	d2 h6	d3	l1	l2	l3	l4	R			
12,00	12	10	83	18	38	45	2,00	3	SCM951-1200Z03R-R0200HA-HU318	31080117
16,00	16	13,40	92	24	47	45	2,00	3	SCM951-1600Z03R-R0200HA-HU318	31080119
16,00	16	13,40	92	24	47	45	3,00	3	SCM951-1600Z03R-R0300HA-HU318	31080140
20,00	20	16,80	104	35	56	48	2,00	3	SCM951-2000Z03R-R0200HA-HU318	31080142
20,00	20	16,80	104	35	56	48	3,00	3	SCM951-2000Z03R-R0300HA-HU318	31080143
20,00	20	16,80	104	35	56	48	4,00	3	SCM951-2000Z03R-R0400HA-HU318	31080144
25,00	25	21	108	35	52	56	3,00	3	SCM951-2500Z03R-R0300HA-HU318	31080145
25,00	25	21	108	35	52	56	4,00	3	SCM951-2500Z03R-R0400HA-HU318	31080146
25,00	25	21	136	38	80	56	3,00	3	SCM961-2500Z03R-R0300HA-HU318	31080147
25,00	25	21	136	38	80	56	4,00	3	SCM961-2500Z03R-R0400HA-HU318	31080148

Inch dimensions | Available upon request

1/2"	1/2"	0,417"	3 1/2"	3/4"	1 5/8"	1,772"	0,09"	3	SCM951-1270Z03R-R0228HA-HU318	31080118
3/4"	3/4"	0,63"	4 1/8"	1 1/4"	2 1/8"	1,89"	0,12"	3	SCM951-1905Z03R-R0305HA-HU318	31080141
1"	1"	0,839"	5"	1 1/2"	2,783"	2,205"	0,12"	3	SCM951-2540Z03R-R0305HA-HU318	31080149

Configurable features

Shank form:
Shank form: HB

Specification:
SCM951-1200Z03R-R0200[shank form]-HU318

Example:

SCM951-1200Z03R-R0200HB-HU318

Shank form HB

Dimensions in mm.

For cutting data recommendations, see end of chapter.

Special designs and other coatings available upon request.



ECU-Mill-Uni-Rough&Finish

Shoulder milling cutter, long design
SCM220

Design:

Diameter of milling cutter: 6.00 – 20.00 mm
Cutting material: HP213
Number of cutting edges: 3 to ø 8 mm
4 from ø 10 mm
Helix angle: 30°

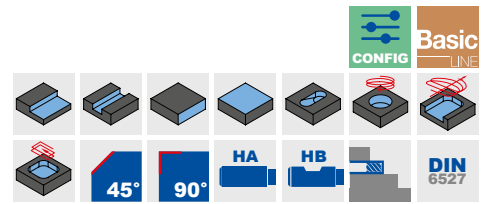
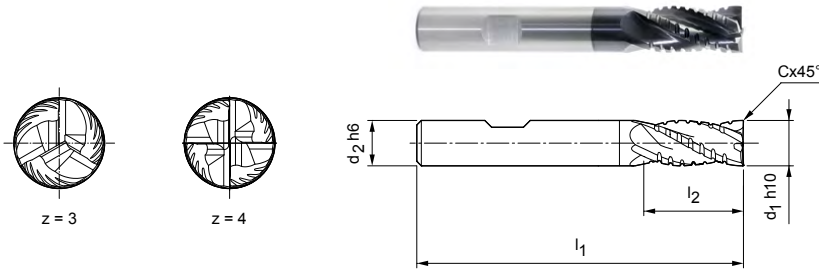

Preferred series in stock

Dimensions					z	Specification	Order no.
d ₁ h10	d ₂ h6	l ₁	l ₂	Cx45°			
6,00	6	57	13	–	3	SCM220-0600Z03R-S-HB-HP213	30393471
8,00	8	63	19	0,08	3	SCM220-0800Z03R-F0008HB-HP213	30393472
10,00	10	72	22	0,10	4	SCM220-1000Z04R-F0010HB-HP213	30393473
12,00	12	83	26	0,12	4	SCM220-1200Z04R-F0012HB-HP213	30393474
16,00	16	92	32	0,16	4	SCM220-1600Z04R-F0016HB-HP213	30393476
20,00	20	104	38	0,20	4	SCM220-2000Z04R-F0020HB-HP213	30393478

Available on request

14,00	14	83	26	0,14	4	SCM220-1400Z04R-F0014HB-HP213	30393475
18,00	18	92	32	0,18	4	SCM220-1800Z04R-F0018HB-HP213	30393477

Configurable features



Shank form:
Shank form: HA



Specification:
SCM220-0800Z03R-F0008[shank form]-HP213

Example:

SCM220-0800Z03R-F0008HA-HP213

Shank form HA

Dimensions in mm.

For cutting data recommendations, see end of chapter.

Special designs and other coatings available upon request.

CPMill®-Uni-Rough&Finish

Design with CFS connection
CPM140

Design:

Diameter of milling cutter: 8.00 – 25.00 mm
Cutting material: HP383
Number of cutting edges: 4 to \varnothing 12.00 mm
5 at \varnothing 16.00 mm
6 from \varnothing 20.00 mm

Helix angle: 45°

Special features: Special roughing geometry, also suitable for unstable clamping.

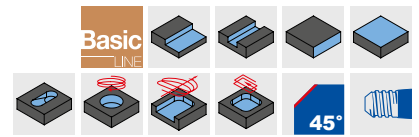
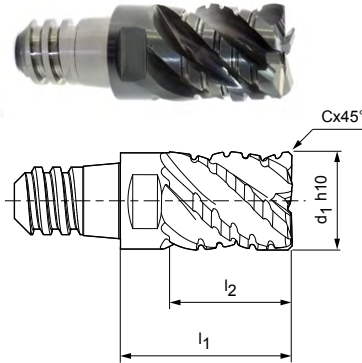
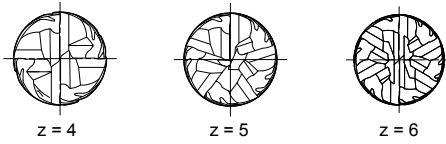

Preferred series in stock

Dimensions					z	a _p max.	SW	Specification	Order no.
d ₁ h10	CFS size	l ₁	l ₂	Cx45°					
8,00	6	15	10	0,16	4	7,5	SW 6	CPM140-0800Z04-F0016-06-HP383	30371395
10,00	8	18	12,5	0,20	4	9,4	SW 8	CPM140-1000Z04-F0020-08-HP383	30371396
12,00	10	22	15	0,24	4	11,3	SW 10	CPM140-1200Z04-F0024-10-HP383	30371397
16,00	12	28	20	0,32	5	15	SW 13	CPM140-1600Z05-F0032-12-HP383	30371398
20,00	16	35	25	0,40	6	18,8	SW 16	CPM140-2000Z06-F0040-16-HP383	30371400

Available on request

25,00	20	45	32	0,5	6	23,4	SW 21	CPM140-2500Z06-F0050-20-HP383	30371401
-------	----	----	----	-----	---	------	-------	-------------------------------	----------

Accessories

	CFS replaceable head holders CFS101 CFS201	Page 218
-------------------------------------------------------------------------------------	-------------------------------------------------	----------

Dimensions in mm.

For cutting data recommendations, see end of chapter.

Special designs and other coatings available upon request.

Cutting data recommendations for shoulder milling cutters

Feed and cutting speed

Tool length/correction factor:	
Length	f_z & v_c
short	1
long	0.9

OptiMill-Uni-HPC-Rough | SCM700, 710

MMG*		Workpiece material	Strength/hardness [N/mm ²] [HRC]	Cooling		
				MQL/Air	Dry	Coolant
P	P1.1	Structural, free-cutting, case hardened and heat-treated steels, non-alloy	< 700	✓	✓	✓
	P1.2	Structural, free-cutting, case hardened and heat-treated steels, non-alloy	< 1200	✓	✓	✓
	P2.1	Nitrided, case hardened and heat-treated steels, alloy	< 900	✓	✓	✓
	P2.2	Nitrided, case hardened and heat-treated steels, alloy	< 1400	✓		✓
	P3.1	Tool, bearing, spring and high-speed steels**	< 800	✓	✓	✓
	P3.2	Tool, bearing, spring and high-speed steels**	< 1000	✓		✓
	P3.3	Tool, bearing, spring and high-speed steels**	< 1500	✓		✓
	P4.1	Stainless steels, ferritic and martensitic		✓		✓
	P5.1	Cast steel				✓
	P6.1	Stainless cast steel, ferritic and martensitic				✓
M	M1.1	Stainless steels, austenitic	< 700	✓		✓
	M1.2	Stainless steels, ferritic/austenitic (duplex)	< 1000			✓
	M2.1	Stainless/heat-resistant cast steel, austenitic	< 700	✓		✓
	M3.1	Stainless cast steel, ferritic/austenitic (duplex)	< 1000			✓
K	K1.1	Cast iron with lamellar graphite (grey cast iron), GJL	< 300	✓	✓	✓
	K2.1	Cast iron with spheroidal graphite, GJS	< 500	✓	✓	✓
	K2.2	Cast iron with spheroidal graphite, GJS	≤ 800	✓	✓	✓
	K2.3	Cast iron with spheroidal graphite, GJS	> 800	✓	✓	✓
	K3.1	Cast iron with spheroidal graphite, GJV; malleable cast iron, GJM	< 500	✓	✓	✓
	K3.2	Cast iron with spheroidal graphite, GJV; malleable cast iron, GJM	> 500	✓	✓	✓

* MAPAL machining groups

** If the alloy parts Cr, Mo, Ni, V, W in total > 8%, then select the next highest MAPAL machining group.

Groove milling

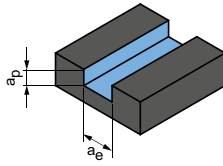

$$a_p = 1 \times D$$

$$a_e = 1 \times D$$

Roughing

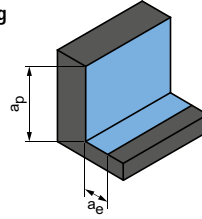

$$a_p = 1.5 \times D$$

$$a_e = 0.25 \times D$$

	v_c [m/min]	f_z [mm]							v_c [m/min]	f_z [mm]						
		Diameter of milling cutter [mm]								Diameter of milling cutter [mm]						
		6.00	8.00	10.00	12.00	16.00	20.00	25.00		6.00	8.00	10.00	12.00	16.00	20.00	25.00
	200	0.035	0.044	0.053	0.061	0.075	0.085	0.095	355	0.059	0.075	0.090	0.103	0.126	0.145	0.161
	165	0.032	0.041	0.050	0.057	0.070	0.080	0.089	290	0.055	0.070	0.084	0.097	0.118	0.135	0.151
	180	0.035	0.044	0.053	0.061	0.075	0.085	0.095	325	0.059	0.075	0.090	0.103	0.126	0.145	0.161
	125	0.029	0.037	0.044	0.051	0.062	0.071	0.079	225	0.049	0.063	0.075	0.086	0.105	0.120	0.134
	120	0.034	0.043	0.051	0.059	0.072	0.082	0.092	210	0.057	0.073	0.087	0.100	0.122	0.140	0.156
	110	0.032	0.041	0.049	0.056	0.068	0.078	0.087	195	0.054	0.069	0.083	0.095	0.116	0.132	0.148
	100	0.030	0.038	0.046	0.053	0.065	0.074	0.082	180	0.051	0.065	0.078	0.090	0.110	0.125	0.140
	80	0.023	0.030	0.035	0.041	0.050	0.057	0.063	145	0.039	0.050	0.060	0.069	0.084	0.096	0.108
	120	0.034	0.043	0.051	0.059	0.072	0.082	0.092	215	0.057	0.073	0.087	0.100	0.122	0.140	0.156
80	0.016	0.021	0.025	0.028	0.035	0.040	0.044	145	0.027	0.035	0.042	0.048	0.059	0.067	0.075	
	55	0.020	0.026	0.031	0.036	0.043	0.050	0.055	110	0.034	0.044	0.053	0.060	0.074	0.084	0.094
	50	0.017	0.021	0.026	0.029	0.036	0.041	0.046	105	0.028	0.036	0.044	0.050	0.061	0.070	0.078
	60	0.022	0.028	0.034	0.039	0.047	0.054	0.060	120	0.037	0.048	0.057	0.066	0.080	0.092	0.102
	55	0.017	0.022	0.027	0.031	0.037	0.043	0.048	110	0.029	0.038	0.045	0.052	0.063	0.072	0.081
	215	0.058	0.074	0.088	0.102	0.124	0.142	0.158	440	0.098	0.125	0.150	0.172	0.211	0.241	0.269
	200	0.049	0.063	0.075	0.086	0.106	0.121	0.135	405	0.083	0.106	0.128	0.147	0.179	0.205	0.228
	160	0.040	0.052	0.062	0.071	0.087	0.099	0.111	330	0.069	0.088	0.105	0.121	0.147	0.169	0.188
	90	0.023	0.030	0.035	0.041	0.050	0.057	0.063	185	0.039	0.050	0.060	0.069	0.084	0.096	0.108
	145	0.040	0.052	0.062	0.071	0.087	0.099	0.111	295	0.069	0.088	0.105	0.121	0.147	0.169	0.188
	135	0.035	0.044	0.053	0.061	0.075	0.085	0.095	275	0.059	0.075	0.090	0.103	0.126	0.145	0.161

The specified machining values are guide values.
The optimum data for the respective machining task should be determined during the test or machining.

Cutting data recommendations for shoulder milling cutters

Feed and cutting speed

Groove milling

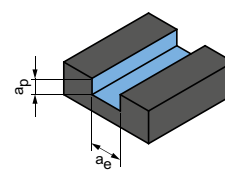

$$a_p = 1 \times D$$

$$a_e = 1 \times D$$

OptiMill-Uni-Wave | SCM800, 880, 881, 890, 900, 910

MMG*	Workpiece material	Strength/ hardness [N/mm ²] [HRC]	Cooling			v _c [m/min]	f _z [mm]									
			MQL/Air	Dry	Coolant		Diameter of milling cutter [mm]									
							4.00	6.00	8.00	10.00	12.00	16.00	20.00	25.00		
P	P1.1	Structural, free-cutting, case hardened and heat-treated steels, non-alloy	< 700	✓	✓	✓	200	0.027	0.038	0.049	0.058	0.067	0.082	0.094	0.105	
	P1.2	Structural, free-cutting, case hardened and heat-treated steels, non-alloy	< 1200	✓	✓	✓	160	0.025	0.036	0.046	0.054	0.063	0.077	0.087	0.098	
	P2.1	Nitrided, case hardened and heat-treated steels, alloy	< 900	✓	✓	✓	180	0.027	0.038	0.049	0.058	0.067	0.082	0.094	0.105	
	P2.2	Nitrided, case hardened and heat-treated steels, alloy	< 1400	✓	✓	✓	125	0.022	0.032	0.041	0.049	0.056	0.068	0.078	0.087	
	P3.1	Tool, bearing, spring and high-speed steels**	< 800	✓	✓	✓	115	0.026	0.037	0.047	0.056	0.065	0.079	0.091	0.101	
	P3.2	Tool, bearing, spring and high-speed steels**	< 1000	✓	✓	✓	110	0.024	0.035	0.045	0.054	0.062	0.075	0.086	0.096	
	P3.3	Tool, bearing, spring and high-speed steels**	< 1500	✓	✓	✓	100	0.023	0.033	0.042	0.051	0.058	0.071	0.081	0.091	
	P4	P4.1	Stainless steels, ferritic and martensitic		✓	✓	80	0.018	0.025	0.033	0.039	0.045	0.055	0.062	0.07	
	P5	P5.1	Cast steel			✓	120	0.026	0.037	0.047	0.056	0.065	0.079	0.091	0.101	
	P6	P6.1	Stainless cast steel, ferritic and martensitic			✓	80	0.012	0.018	0.023	0.027	0.031	0.038	0.044	0.049	
M	M1.1	Stainless steels, austenitic	< 700	✓		✓	55	0.015	0.022	0.028	0.034	0.039	0.048	0.055	0.061	
	M1.2	Stainless steels, ferritic/austenitic (duplex)	< 1000			✓	50	0.013	0.018	0.024	0.028	0.032	0.04	0.045	0.051	
	M2	M2.1	Stainless/heat-resistant cast steel, austenitic	< 700	✓		✓	60	0.017	0.024	0.031	0.037	0.042	0.052	0.059	0.066
	M3	M3.1	Stainless cast steel, ferritic/austenitic (duplex)	< 1000			✓	55	0.013	0.019	0.024	0.029	0.034	0.041	0.047	0.052
K	K1	K1.1	Cast iron with lamellar graphite (grey cast iron), GJL	< 300	✓	✓	✓	215	0.044	0.064	0.081	0.097	0.112	0.137	0.156	0.174
	K1	K2.1	Cast iron with spheroidal graphite, GJS	< 500	✓	✓	✓	200	0.038	0.054	0.069	0.083	0.095	0.116	0.133	0.148
	K2	K2.2	Cast iron with spheroidal graphite, GJS	≤ 800	✓	✓	✓	160	0.031	0.045	0.057	0.068	0.078	0.096	0.109	0.122
	K2	K2.3	Cast iron with spheroidal graphite, GJS	> 800	✓	✓	✓	90	0.018	0.025	0.033	0.039	0.045	0.055	0.062	0.07
	K3	K3.1	Cast iron with spheroidal graphite, GJV; malleable cast iron, GJM	< 500	✓	✓	✓	145	0.031	0.045	0.057	0.068	0.078	0.096	0.109	0.122
	K3	K3.2	Cast iron with spheroidal graphite, GJV; malleable cast iron, GJM	> 500	✓	✓	✓	135	0.027	0.038	0.049	0.058	0.067	0.082	0.094	0.105

Tool length/correction factor

Length	v _c	f _z
short / long / 3xD	1	1
overlong / 4xD	0.8	0.9
extra long / 5xD	0.6	0.7

Correction factors trochoidal milling

Length	v _c			a _e	h _m
	P	K	M		
Factor 2xD	1.10	1.05	1.05	1.05	1.05
Factor 3xD / short / long / overlong	1.00	1.00	1.00	1.00	1.00
Extra long	0.90	0.95	0.92	0.92	0.95
Factor 4xD	0.85	0.92	0.90	0.90	0.94
Factor 5xD	0.60	0.80	0.80	0.80	0.87

Please be aware:

Using the SCM900 in the 3xD design is only recommended up to a maximum cutting width of 0.25xD.

Note:

In the case of trochoidal milling, the specified cutting conditions change during the machining process. This also depends on the CAM software used and the machining position of the tool in the workpiece. The feed and cutting width or contact angle are constantly changing during machining in order to achieve, as far as is possible, the most constant average chip thickness depending on the contour.

* MAPAL machining groups

** If the alloy parts Cr, Mo, Ni, V, W in total > 8%, then select the next highest MAPAL machining group.

Roughing

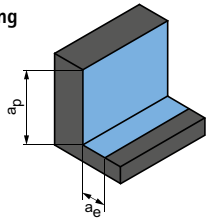

$$a_p = 1.5xD$$

$$a_e = 0.25xD$$

Roughing ***

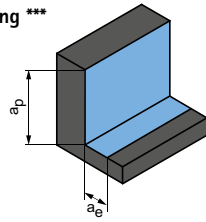

$$a_p = 3xD$$

$$a_e = 0.2xD$$

*** Valid for SCM900 - design 3xD

Trochoidal milling

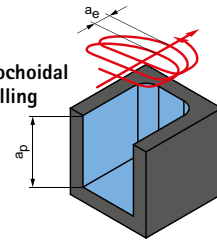

a_p = depending on max. machining depth of the tool
 a_e = depending on the workpiece material

v_c [m/min]	f_z [mm]								v_c [m/min]	f_z [mm]								v_c [m/min]	f_z [mm] in % of D	a_e [mm] in % of D	h_m [mm] in % of D
	Diameter of milling cutter [mm]									Diameter of milling cutter [mm]											
	4.00	6.00	8.00	10.00	12.00	16.00	20.00	25.00		5.00	6.00	8.00	10.00	12.00	16.00	20.00	25.00				
405	0.045	0.065	0.083	0.099	0.114	0.139	0.159	0.177	355	0.054	0.064	0.082	0.098	0.112	0.137	0.157	0.175	380-520	1.4-2.0	14-18	0.66-0.80
330	0.042	0.06	0.077	0.092	0.106	0.13	0.148	0.166	290	0.051	0.060	0.076	0.091	0.105	0.128	0.146	0.163	320-460	1.2-1.8	12-16	0.62-0.76
370	0.045	0.065	0.083	0.099	0.114	0.139	0.159	0.177	320	0.054	0.064	0.082	0.098	0.112	0.137	0.157	0.175	340-480	1.2-1.8	10-14	0.58-0.71
260	0.038	0.054	0.069	0.083	0.095	0.116	0.132	0.148	225	0.045	0.053	0.068	0.081	0.094	0.114	0.131	0.146	280-380	1.0-1.6	8-12	0.56-0.68
240	0.044	0.063	0.08	0.096	0.11	0.134	0.154	0.171	210	0.053	0.062	0.079	0.094	0.109	0.133	0.152	0.169	250-360	1.1-1.7	9-15	0.56-0.67
220	0.041	0.059	0.076	0.091	0.104	0.127	0.146	0.163	190	0.050	0.059	0.075	0.090	0.103	0.126	0.144	0.161	230-340	0.9-1.5	8-13	0.54-0.64
200	0.039	0.056	0.072	0.086	0.099	0.12	0.138	0.154	175	0.047	0.055	0.071	0.085	0.097	0.119	0.136	0.152	210-320	0.8-1.4	6-12	0.52-0.62
165	0.03	0.043	0.055	0.066	0.076	0.093	0.106	0.118	145	0.036	0.043	0.054	0.065	0.075	0.091	0.105	0.117	180-260	0.8-1.2	6-12	0.50-0.60
245	0.044	0.063	0.08	0.096	0.11	0.134	0.154	0.171	215	0.053	0.062	0.079	0.094	0.109	0.133	0.152	0.169	220-300	1.2-1.8	8-12	0.54-0.62
165	0.021	0.03	0.039	0.046	0.053	0.065	0.074	0.083	145	0.025	0.030	0.038	0.046	0.052	0.064	0.073	0.082	160-240	0.8-1.4	6-12	0.50-0.60
110	0.026	0.038	0.048	0.058	0.066	0.081	0.093	0.103	110	0.032	0.037	0.048	0.057	0.066	0.080	0.092	0.102	140-220	0.6-1.0	5-10	0.48-0.60
105	0.022	0.031	0.04	0.048	0.055	0.067	0.077	0.086	105	0.026	0.031	0.039	0.047	0.054	0.066	0.076	0.085	110-180	0.6-1.0	5-10	0.46-0.58
120	0.029	0.041	0.052	0.063	0.072	0.088	0.101	0.112	125	0.034	0.040	0.052	0.062	0.071	0.087	0.099	0.111	130-200	0.8-1.2	6-12	0.52-0.60
110	0.023	0.032	0.041	0.05	0.057	0.07	0.079	0.089	110	0.027	0.032	0.041	0.049	0.056	0.069	0.078	0.088	120-180	0.8-1.2	5-10	0.46-0.56
440	0.075	0.108	0.138	0.165	0.19	0.232	0.265	0.296	450	0.091	0.106	0.136	0.163	0.187	0.229	0.262	0.292	400-500	2.0-2.6	15-20	0.64-0.78
405	0.064	0.092	0.117	0.14	0.161	0.197	0.225	0.251	410	0.077	0.090	0.116	0.138	0.159	0.194	0.222	0.248	340-500	1.8-2.4	12-16	0.62-0.7
330	0.053	0.076	0.096	0.116	0.133	0.162	0.185	0.207	335	0.063	0.075	0.095	0.114	0.131	0.160	0.183	0.204	300-440	1.6-2.2	10-14	0.58-0.68
185	0.03	0.043	0.055	0.066	0.076	0.093	0.106	0.118	185	0.036	0.043	0.054	0.065	0.075	0.091	0.105	0.117	180-260	1.4-2.0	8-12	0.56-0.68
295	0.053	0.076	0.096	0.116	0.133	0.162	0.185	0.207	300	0.063	0.075	0.095	0.114	0.131	0.160	0.183	0.204	280-360	1.6-2.2	10-16	0.6-0.68
275	0.045	0.065	0.083	0.099	0.114	0.139	0.159	0.177	280	0.054	0.064	0.082	0.098	0.112	0.137	0.157	0.175	210-340	1.4-2.0	10-16	0.58-0.66

The specified machining values are guide values.
 The optimum data for the respective machining task should be determined during the test or machining.

Cutting data recommendations for shoulder milling cutters

Feed and cutting speed

Groove milling

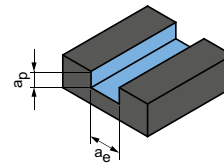

$$a_p = 0.3 \times D$$

$$a_e = 1 \times D$$

OptiMill-SPM-Rough | SCM951, 961

MMG*	Workpiece material	Strength/hardness [N/mm ²] [HRC]	Cooling			v _c [m/min]	f _z [mm]			
			MQL/Air	Dry	Coolant		Diameter of milling cutter [mm]			
							12.00	16.00	20.00	25.00
N N1	N1.1	Aluminium, non-alloy and alloy < 3 % Si	✓	✓	✓	1,530	0.271	0.331	0.378	0.422
	N1.2	Aluminium, alloy ≤ 7 % Si	✓	✓	✓	1,015	0.284	0.347	0.397	0.443
	N1.3	Aluminium, alloy > 7-12 % Si	✓	✓	✓	810	0.298	0.364	0.416	0.464
	N1.4	Aluminium, alloy > 12 % Si	✓	✓	✓	585	0.325	0.397	0.454	0.506

* MAPAL machining groups

** If the alloy parts Cr, Mo, Ni, V, W in total > 8%, then select the next highest MAPAL machining group.

Groove milling

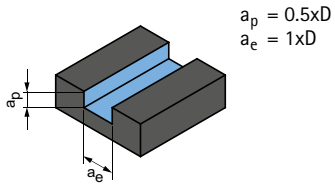

Groove milling

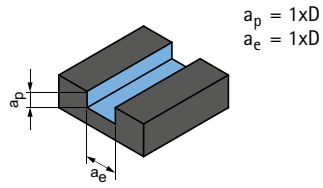

	v_c [m/min]	f_z [mm]				v_c [m/min]	f_z [mm]			
		Diameter of milling cutter [mm]					Diameter of milling cutter [mm]			
		12.00	16.00	20.00	25.00		12.00	16.00	20.00	25.00
	1,530	0.235	0.287	0.328	0.366	1,530	0.186	0.228	0.260	0.291
	1,015	0.247	0.301	0.345	0.384	1,015	0.196	0.239	0.273	0.305
	810	0.258	0.316	0.361	0.403	810	0.205	0.251	0.286	0.320
	585	0.282	0.344	0.394	0.439	585	0.224	0.273	0.313	0.349

The specified machining values are guide values.
The optimum data for the respective machining task should be determined during the test or machining.

Cutting data recommendations for shoulder milling cutters

Feed and cutting speed

Tool length/correction factor:	
Length	f_z & v_c
Short	1
Long	0,9
Overlong	0,8
Extra long	0,6

Groove milling

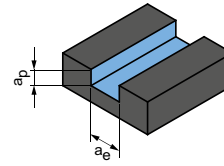

$$a_p = 1xD$$

$$a_e = 1xD$$

ECU-Mill-Uni-Rough&Finish | SCM220

MMG*	Workpiece material	Strength/hardness [N/mm ²] [HRC]	Cooling			v_c [m/min]	f_z [mm]							
			MQL/Air	Dry	Coolant		Diameter of milling cutter [mm]							
							6.00	8.00	10.00	12.00	16.00	20.00	25.00	
P	P1.1	Structural, free-cutting, case hardened and heat-treated steels, non-alloy	< 700	✓	✓	✓	140	0.028	0.035	0.042	0.049	0.060	0.068	0.076
	P1.2	Structural, free-cutting, case hardened and heat-treated steels, non-alloy	< 1200	✓	✓	✓	115	0.026	0.033	0.040	0.046	0.056	0.064	0.071
	P2.1	Nitrided, case hardened and heat-treated steels, alloy	< 900	✓	✓	✓	125	0.028	0.035	0.042	0.049	0.060	0.068	0.076
	P2.2	Nitrided, case hardened and heat-treated steels, alloy	< 1400	✓	✓	✓	90	0.023	0.030	0.035	0.041	0.050	0.057	0.063
	P3.1	Tool, bearing, spring and high-speed steels**	< 800	✓	✓	✓	85	0.027	0.034	0.041	0.047	0.058	0.066	0.074
	P3.2	Tool, bearing, spring and high-speed steels**	< 1000	✓	✓	✓	75	0.025	0.033	0.039	0.045	0.055	0.062	0.070
	P3.3	Tool, bearing, spring and high-speed steels**	< 1500	✓	✓	✓	70	0.024	0.031	0.037	0.042	0.052	0.059	0.066
	P4	P4.1	Stainless steels, ferritic and martensitic		✓	✓	55	0.018	0.024	0.028	0.033	0.040	0.045	0.051
P5	P5.1	Cast steel			✓	85	0.027	0.034	0.041	0.047	0.058	0.066	0.074	
P6	P6.1	Stainless cast steel, ferritic and martensitic			✓	55	0.013	0.017	0.020	0.023	0.028	0.032	0.035	
M	M1.1	Stainless steels, austenitic	< 700	✓		✓	40	0.016	0.021	0.025	0.028	0.035	0.040	0.044
	M1.2	Stainless steels, ferritic/austenitic (duplex)	< 1000			✓	35	0.013	0.017	0.021	0.024	0.029	0.033	0.037
	M2.1	Stainless/heat-resistant cast steel, austenitic	< 700	✓		✓	40	0.018	0.022	0.027	0.031	0.038	0.043	0.048
	M3.1	Stainless cast steel, ferritic/austenitic (duplex)	< 1000			✓	40	0.014	0.018	0.021	0.024	0.030	0.034	0.038
K	K1.1	Cast iron with lamellar graphite (grey cast iron), GJL	< 300	✓	✓	✓	150	0.046	0.059	0.071	0.081	0.099	0.114	0.127
	K2.1	Cast iron with spheroidal graphite, GJS	< 500	✓	✓	✓	140	0.039	0.050	0.060	0.069	0.084	0.097	0.108
	K2.2	Cast iron with spheroidal graphite, GJS	500-800	✓	✓	✓	115	0.032	0.041	0.050	0.057	0.070	0.080	0.089
	K2.3	Cast iron with spheroidal graphite, GJS	> 800	✓	✓	✓	65	0.018	0.024	0.028	0.033	0.040	0.045	0.051
	K3.1	Cast iron with spheroidal graphite, GJV; malleable cast iron, GJM	< 500	✓	✓	✓	100	0.032	0.041	0.050	0.057	0.070	0.080	0.089
	K3.2	Cast iron with spheroidal graphite, GJV; malleable cast iron, GJM	> 500	✓	✓	✓	95	0.028	0.035	0.042	0.049	0.060	0.068	0.076
N	N1.1	Aluminium, non-alloy and alloy < 3 % Si		✓	✓	✓	535	0.047	0.060	0.072	0.083	0.101	0.116	0.129
	N1.2	Aluminium, alloy ≤ 7 % Si		✓	✓	✓	355	0.049	0.063	0.076	0.087	0.106	0.122	0.136
	N1.3	Aluminium, alloy > 7-12 % Si		✓	✓	✓	285	0.052	0.066	0.079	0.091	0.111	0.127	0.142
	N1.4	Aluminium, alloy > 12 % Si		✓	✓	✓	205	0.057	0.072	0.087	0.099	0.121	0.139	0.155
	N2.1	Copper, non-alloy and low-alloy	< 300	✓	✓	✓	205	0.038	0.048	0.058	0.066	0.081	0.093	0.103
	N2.2	Copper, alloy	> 300	✓	✓	✓	155	0.038	0.048	0.058	0.066	0.081	0.093	0.103
	N2.3	Brass, bronze, gunmetal	< 1200	✓	✓	✓	255	0.024	0.030	0.036	0.041	0.051	0.058	0.065

* MAPAL machining groups

** If the alloy parts Cr, Mo, Ni, V, W in total > 8%, then select the next highest MAPAL machining group.

Roughing

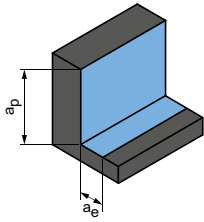

$$a_p = 1.5xD$$

$$a_e = 0.25xD$$

Finishing

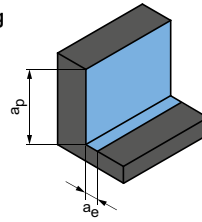

$$a_p = 1.5xD$$

$$a_e = 0.1xD$$

	v_c [m/min]	f_z [mm]							v_c [m/min]	f_z [mm]						
		Diameter of milling cutter [mm]								Diameter of milling cutter [mm]						
		6.00	8.00	10.00	12.00	16.00	20.00	25.00		6.00	8.00	10.00	12.00	16.00	20.00	25.00
	250	0.047	0.060	0.072	0.083	0.101	0.116	0.129	335	0.074	0.095	0.114	0.131	0.160	0.183	0.204
	205	0.044	0.056	0.067	0.077	0.094	0.108	0.120	275	0.069	0.089	0.106	0.122	0.149	0.171	0.190
	225	0.047	0.060	0.072	0.083	0.101	0.116	0.129	305	0.074	0.095	0.114	0.131	0.160	0.183	0.204
	160	0.039	0.050	0.060	0.069	0.084	0.096	0.108	215	0.062	0.079	0.095	0.109	0.133	0.152	0.170
	145	0.045	0.058	0.070	0.080	0.098	0.112	0.125	200	0.072	0.092	0.110	0.127	0.155	0.177	0.197
	135	0.043	0.055	0.066	0.076	0.093	0.106	0.118	185	0.068	0.087	0.104	0.120	0.147	0.168	0.187
	125	0.041	0.052	0.062	0.072	0.088	0.100	0.112	170	0.064	0.082	0.099	0.113	0.139	0.158	0.177
	100	0.031	0.040	0.048	0.055	0.067	0.077	0.086	140	0.050	0.063	0.076	0.087	0.107	0.122	0.136
	150	0.045	0.058	0.070	0.080	0.098	0.112	0.125	205	0.072	0.092	0.110	0.127	0.155	0.177	0.197
	100	0.022	0.028	0.034	0.039	0.047	0.054	0.060	140	0.035	0.044	0.053	0.061	0.075	0.085	0.095
	75	0.027	0.035	0.042	0.048	0.059	0.067	0.075	115	0.043	0.055	0.066	0.076	0.093	0.107	0.119
	70	0.023	0.029	0.035	0.040	0.049	0.056	0.062	105	0.036	0.046	0.055	0.063	0.077	0.088	0.099
	85	0.030	0.038	0.046	0.052	0.064	0.073	0.082	125	0.047	0.060	0.072	0.083	0.101	0.116	0.129
	75	0.024	0.030	0.036	0.041	0.051	0.058	0.065	115	0.037	0.048	0.057	0.065	0.080	0.091	0.102
	310	0.078	0.100	0.120	0.138	0.169	0.193	0.215	455	0.124	0.158	0.190	0.218	0.266	0.305	0.340
	285	0.067	0.085	0.102	0.117	0.143	0.164	0.183	415	0.105	0.135	0.161	0.185	0.226	0.259	0.289
	230	0.055	0.070	0.084	0.097	0.118	0.135	0.151	340	0.087	0.111	0.133	0.153	0.187	0.213	0.238
	130	0.031	0.040	0.048	0.055	0.067	0.077	0.086	190	0.050	0.063	0.076	0.087	0.107	0.122	0.136
	205	0.055	0.070	0.084	0.097	0.118	0.135	0.151	300	0.087	0.111	0.133	0.153	0.187	0.213	0.238
	195	0.047	0.060	0.072	0.083	0.101	0.116	0.129	285	0.074	0.095	0.114	0.131	0.160	0.183	0.204
	825	0.066	0.084	0.101	0.116	0.142	0.162	0.181	985	0.092	0.117	0.140	0.161	0.197	0.225	0.252
	550	0.069	0.088	0.106	0.122	0.149	0.170	0.190	655	0.096	0.123	0.147	0.169	0.207	0.237	0.264
	440	0.073	0.093	0.111	0.128	0.156	0.178	0.199	525	0.101	0.129	0.154	0.178	0.217	0.248	0.277
	315	0.079	0.101	0.121	0.139	0.170	0.194	0.217	380	0.110	0.141	0.168	0.194	0.237	0.270	0.302
	315	0.053	0.067	0.081	0.093	0.113	0.130	0.145	380	0.073	0.094	0.112	0.129	0.158	0.180	0.201
	235	0.053	0.067	0.081	0.093	0.113	0.130	0.145	285	0.073	0.094	0.112	0.129	0.158	0.180	0.201
	395	0.033	0.042	0.050	0.058	0.071	0.081	0.090	470	0.046	0.059	0.070	0.081	0.099	0.113	0.126

The specified machining values are guide values.
The optimum data for the respective machining task should be determined during the test or machining.

Cutting data recommendations for shoulder milling cutters

Feed and cutting speed

Correction factor:	
Length	f_z & v_c
A/B	1.0
C	0.9
D	0.7
E	0.6

CPMill-Uni-Rough&Finish | CPM140

MMG*		Workpiece material	Strength/hardness [N/mm ²] [HRC]	Cooling		
				MQL/Air	Dry	Coolant
P	P1	P1.1 Structural, free-cutting, case hardened and heat-treated steels, non-alloy	< 700	✓	✓	✓
		P1.2 Structural, free-cutting, case hardened and heat-treated steels, non-alloy	< 1200	✓	✓	✓
	P2	P2.1 Nitrided, case hardened and heat-treated steels, alloy	< 900	✓	✓	✓
		P2.2 Nitrided, case hardened and heat-treated steels, alloy	< 1400	✓		✓
	P3	P3.1 Tool, bearing, spring and high-speed steels**	< 800	✓	✓	✓
		P3.2 Tool, bearing, spring and high-speed steels**	< 1000	✓		✓
		P3.3 Tool, bearing, spring and high-speed steels**	< 1500	✓		✓
	P5	P5.1 Cast steel				✓
K	K1	K1.1 Cast iron with lamellar graphite (grey cast iron), GJL	< 300	✓	✓	✓
		K2.1 Cast iron with spheroidal graphite, GJS	< 500	✓	✓	✓
	K2	K2.2 Cast iron with spheroidal graphite, GJS	500-800	✓	✓	✓
		K2.3 Cast iron with spheroidal graphite, GJS	> 800	✓	✓	✓
	K3	K3.1 Cast iron with spheroidal graphite, GJV; malleable cast iron, GJM	< 500	✓	✓	✓
		K3.2 Cast iron with spheroidal graphite, GJV; malleable cast iron, GJM	> 500	✓	✓	✓
N	N1	N1.1 Aluminium, non-alloy and alloy < 3 % Si		✓	✓	✓
		N1.2 Aluminium, alloy ≤ 7 % Si		✓	✓	✓
		N1.3 Aluminium, alloy > 7-12 % Si		✓	✓	✓
		N1.4 Aluminium, alloy > 12 % Si		✓	✓	✓
	N2	N2.1 Copper, non-alloy and low-alloy	< 300	✓	✓	✓
		N2.2 Copper, alloy	> 300	✓	✓	✓
		N2.3 Brass, bronze, gunmetal	< 1200	✓	✓	✓

* MAPAL machining groups

** If the alloy parts Cr, Mo, Ni, V, W in total > 8%, then select the next highest MAPAL machining group.

Roughing

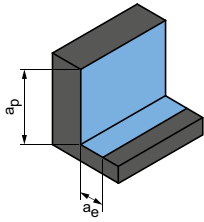

$$a_p = 0.94 \times D$$

$$a_e = 0.25 \times D$$

Finishing

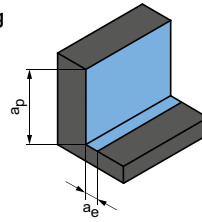

$$a_p = 0.94 \times D$$

$$a_e = 0.1 \times D$$

	v_c [m/min]	f_z [mm]						v_c [m/min]	f_z [mm]					
		Diameter of milling cutter [mm]							Diameter of milling cutter [mm]					
		8.00	10.00	12.00	16.00	20.00	25.00		8.00	10.00	12.00	16.00	20.00	25.00
	250	0.036	0.043	0.050	0.061	0.070	0.078	335	0.057	0.069	0.079	0.096	0.110	0.123
	205	0.034	0.041	0.047	0.057	0.065	0.073	275	0.054	0.064	0.074	0.090	0.103	0.115
	225	0.036	0.043	0.050	0.061	0.070	0.078	305	0.057	0.069	0.079	0.096	0.110	0.123
	160	0.030	0.036	0.042	0.051	0.058	0.065	215	0.048	0.057	0.066	0.080	0.092	0.103
	145	0.035	0.042	0.048	0.059	0.067	0.075	200	0.055	0.066	0.076	0.093	0.107	0.119
	135	0.033	0.040	0.046	0.056	0.064	0.071	185	0.053	0.063	0.072	0.088	0.101	0.113
	125	0.031	0.038	0.043	0.053	0.060	0.067	170	0.050	0.060	0.068	0.084	0.096	0.107
	150	0.035	0.042	0.048	0.059	0.067	0.075	205	0.055	0.066	0.076	0.093	0.107	0.119
	310	0.060	0.072	0.083	0.102	0.116	0.130	455	0.096	0.114	0.132	0.161	0.184	0.205
	285	0.051	0.062	0.071	0.086	0.099	0.110	415	0.081	0.097	0.112	0.137	0.156	0.174
	230	0.042	0.051	0.058	0.071	0.081	0.091	340	0.067	0.080	0.092	0.113	0.129	0.144
	130	0.024	0.029	0.033	0.041	0.046	0.052	190	0.038	0.046	0.053	0.064	0.074	0.082
	205	0.042	0.051	0.058	0.071	0.081	0.091	300	0.067	0.080	0.092	0.113	0.129	0.144
	195	0.036	0.043	0.050	0.061	0.070	0.078	285	0.057	0.069	0.079	0.096	0.110	0.123
	825	0.051	0.061	0.070	0.085	0.098	0.109	985	0.071	0.085	0.097	0.119	0.136	0.152
	550	0.053	0.064	0.073	0.090	0.103	0.114	655	0.074	0.089	0.102	0.125	0.143	0.159
	440	0.056	0.067	0.077	0.094	0.107	0.120	525	0.078	0.093	0.107	0.131	0.150	0.167
	315	0.061	0.073	0.084	0.103	0.117	0.131	380	0.085	0.102	0.117	0.143	0.163	0.182
	315	0.041	0.049	0.056	0.068	0.078	0.087	380	0.057	0.068	0.078	0.095	0.109	0.121
	235	0.041	0.049	0.056	0.068	0.078	0.087	285	0.057	0.068	0.078	0.095	0.109	0.121
	395	0.025	0.030	0.035	0.043	0.049	0.055	470	0.035	0.042	0.049	0.059	0.068	0.076

The specified machining values are guide values.
The optimum data for the respective machining task should be determined during the test or machining.





SHOULDER MILLING CUTTER – FINISHING

Universal application

OptiMill-Uni-HPC-Finish | CPMill-Uni-HPC-Finish _____ 134

Hardened steel

OptiMill-Hardened-Finish _____ 140

Non-ferrous metals

OptiMill-SPM-Finish _____ 145

Technical appendix

Cutting data recommendations _____ 146

OptiMill®-Uni-HPC-Finish

Shoulder milling cutter, 2xD design
SCM830

Design:

Diameter of milling cutter: 4.00 - 20.00 mm
Cutting material: HP213
Number of cutting edges: 7
Helix angle: 45°
Special features: Unequal spacing

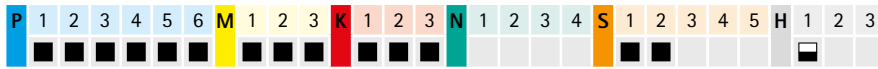
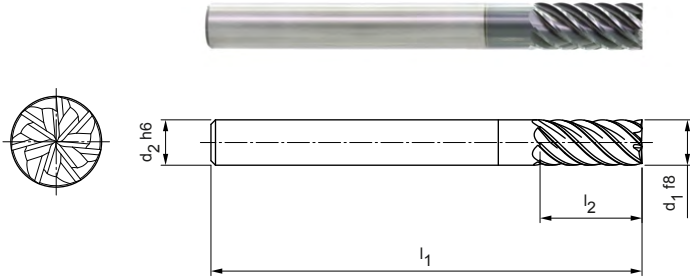

Preferred series in stock

Dimensions					z	Specification	Order no.
d ₁ f8	d ₂ h6	l ₁	l ₂	Cx45°			
4,00	6	57	11	0,04	7	SCM830-0400Z07R-F0004HA2-HP213	30936070
5,00	6	57	13	0,05	7	SCM830-0500Z07R-F0005HA2-HP213	30936071
6,00	6	57	13	0,06	7	SCM830-0600Z07R-F0006HA2-HP213	30936072
8,00	8	63	19	0,08	7	SCM830-0800Z07R-F0008HA2-HP213	30936073
10,00	10	72	22	0,10	7	SCM830-1000Z07R-F0010HA2-HP213	30936074
12,00	12	83	26	0,12	7	SCM830-1200Z07R-F0012HA2-HP213	30936076
14,00	14	83	26	0,14	7	SCM830-1400Z07R-F0014HA2-HP213	30936077
16,00	16	92	32	0,16	7	SCM830-1600Z07R-F0016HA2-HP213	30936078
20,00	20	104	41	0,20	7	SCM830-2000Z07R-F0020HA2-HP213	30936090

Available on request

18,00	18	92	32	0,18	7	SCM830-1800Z07R-F0018HA2-HP213	30936079
-------	----	----	----	------	---	--------------------------------	----------

Configurable features

Shank form:
Shank form: HB

Specification:
SCM830-0400Z07R-F0004[shank form]2-HP213

Example:

SCM830-0400Z07R-F0004HB2-HP213

Shank form HB

Dimensions in mm.

For cutting data recommendations, see end of chapter.

Special designs and other coatings available upon request.

OptiMill®-Uni-HPC-Finish

Shoulder milling cutter, 3xD design
SCM830

Design:

Diameter of milling cutter: 4.00 - 20.00 mm
Cutting material: HP213
Number of cutting edges: 7
Helix angle: ~ 45°
Special features: Unequal spacing

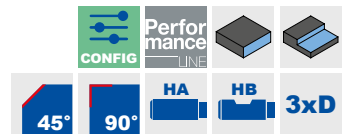
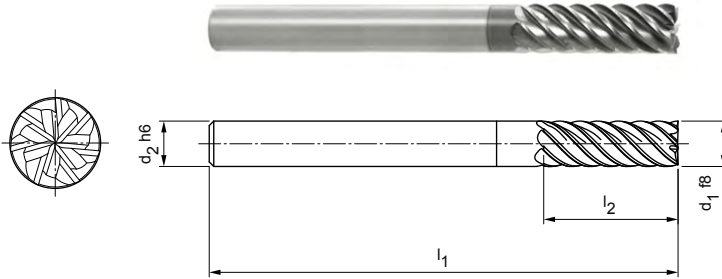
Design with chamfer | Preferred series in stock

Dimensions					z	Specification	Order no.
d ₁ f8	d ₂ h6	l ₁	l ₂	Cx45°			
4,00	6	62	16	0,04	7	SCM830-0400Z07R-F0004HA3-HP213	30936093
5,00	6	62	17	0,05	7	SCM830-0500Z07R-F0005HA3-HP213	30936094
6,00	6	62	18	0,06	7	SCM830-0600Z07R-F0006HA3-HP213	30936095
8,00	8	68	24	0,08	7	SCM830-0800Z07R-F0008HA3-HP213	30936096
10,00	10	80	30	0,10	7	SCM830-1000Z07R-F0010HA3-HP213	30936098
12,00	12	93	36	0,12	7	SCM830-1200Z07R-F0012HA3-HP213	30936099
14,00	14	99	42	0,14	7	SCM830-1400Z07R-F0014HA3-HP213	30936110
16,00	16	108	48	0,16	7	SCM830-1600Z07R-F0016HA3-HP213	30936111
20,00	20	126	60	0,20	7	SCM830-2000Z07R-F0020HA3-HP213	30936114

Design with chamfer | Available on request

18,00	18	117	54	0,18	7	SCM830-1800Z07R-F0018HA3-HP213	30936112
-------	----	-----	----	------	---	--------------------------------	----------

Design with sharp edge | Preferred series in stock

4,00	6	62	16	-	7	SCM830-0400Z07R-S-HA3-HP213	31046210
5,00	6	62	17	-	7	SCM830-0500Z07R-S-HA3-HP213	31046211
6,00	6	62	18	-	7	SCM830-0600Z07R-S-HA3-HP213	31046212
8,00	8	68	24	-	7	SCM830-0800Z07R-S-HA3-HP213	31046213
10,00	10	80	30	-	7	SCM830-1000Z07R-S-HA3-HP213	31046214
12,00	12	93	36	-	7	SCM830-1200Z07R-S-HA3-HP213	31046215
14,00	14	99	42	-	7	SCM830-1400Z07R-S-HA3-HP213	31046216
16,00	16	108	48	-	7	SCM830-1600Z07R-S-HA3-HP213	31046217
20,00	20	126	60	-	7	SCM830-2000Z07R-S-HA3-HP213	31046219

Design with sharp edge | Available on request

18,00	18	117	54	-	7	SCM830-1800Z07R-S-HA3-HP213	31046218
-------	----	-----	----	---	---	-----------------------------	----------

Configurable features

Shank form:
Shank form: HB

Specification:

SCM830-0400Z07R-F0004[shank form]3-HP213

Example:

SCM830-0400Z07R-F0004HB3-HP213

Shank form HB

Dimensions in mm.

For cutting data recommendations, see end of chapter.

Special designs and other coatings available upon request.

OptiMill®-Uni-HPC-Finish

Shoulder milling cutter, 4xD design
SCM830

Design:

Diameter of milling cutter: 6.00 - 25.00 mm
Cutting material: HP213
Number of cutting edges: 7
Helix angle: 45°
Special features: Unequal spacing

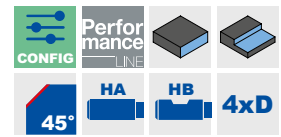
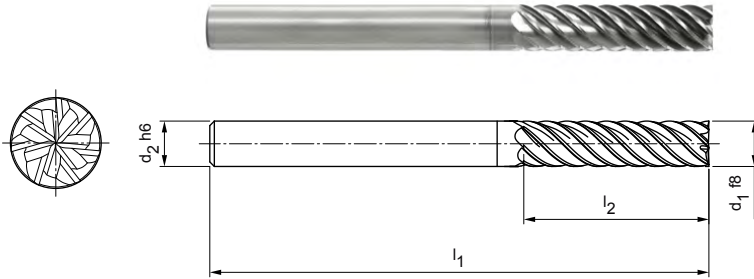

Preferred series in stock

Dimensions					z	Specification	Order no.
d ₁ f8	d ₂ h6	l ₁	l ₂	Cx45°			
6,00	6	66	24	0,06	7	SCM830-0600Z07R-F0006HA4-HP209	30936116
8,00	8	74	32	0,08	7	SCM830-0800Z07R-F0008HA4-HP209	30936117
10,00	10	89	40	0,10	7	SCM830-1000Z07R-F0010HA4-HP209	30936118
12,00	12	100	48	0,12	7	SCM830-1200Z07R-F0012HA4-HP209	30936119
14,00	14	108	56	0,14	7	SCM830-1400Z07R-F0014HA4-HP209	30936131
16,00	16	123	64	0,16	7	SCM830-1600Z07R-F0016HA4-HP209	30936132
20,00	20	140	80	0,20	7	SCM830-2000Z07R-F0020HA4-HP209	30936134

Available on request

18,00	18	130	72	0,18	7	SCM830-1800Z07R-F0018HA4-HP209	30936133
25,00	25	170	100	0,25	7	SCM830-2500Z07R-F0025HA4-HP209	30936136

Configurable features

Shank form:
Shank form: HB

Specification:
SCM830-0600Z07R-F0006[shank form]4-HP209

Example:

SCM830-0600Z07R-F0006HB4-HP209

Shank form HB

Dimensions in mm.

For cutting data recommendations, see end of chapter.

Special designs and other coatings available upon request.

OptiMill®-Uni-HPC-Finish

Shoulder milling cutter, 5xD design
SCM830

Design:

Diameter of milling cutter: 8.00 - 25.00 mm
Cutting material: HP209
Number of cutting edges: 7
Helix angle: ~ 45°
Special features: Unequal spacing

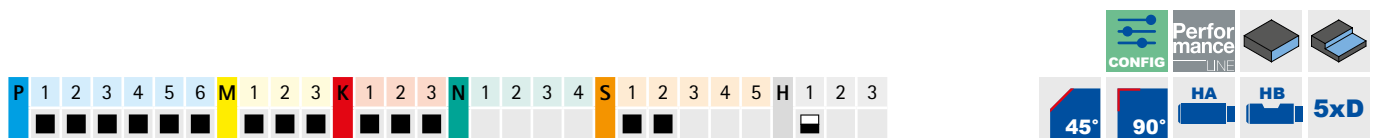
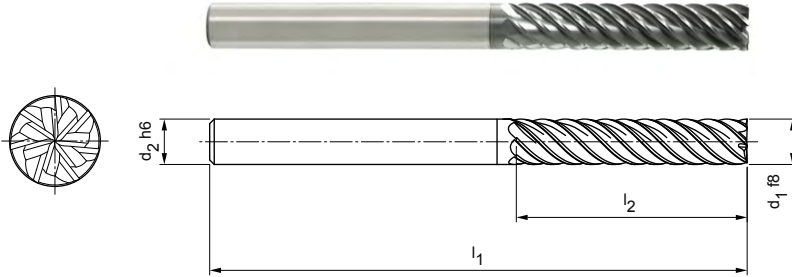

Design with chamfer | Preferred series in stock

Dimensions					z	Specification	Order no.
d ₁ f8	d ₂ h6	l ₁	l ₂	Cx45°			
8,00	8	81	40	0,08	7	SCM830-0800Z07R-F0008HA5-HP209	30936137
10,00	10	96	50	0,10	7	SCM830-1000Z07R-F0010HA5-HP209	30936138
12,00	12	112	60	0,12	7	SCM830-1200Z07R-F0012HA5-HP209	30936139
14,00	14	122	70	0,14	7	SCM830-1400Z07R-F0014HA5-HP209	30936150
16,00	16	136	80	0,16	7	SCM830-1600Z07R-F0016HA5-HP209	30936151
20,00	20	160	100	0,20	7	SCM830-2000Z07R-F0020HA5-HP209	30936153

Design with chamfer | Available on request

18,00	18	147	90	0,18	7	SCM830-1800Z07R-F0018HA5-HP209	30936152
25,00	25	195	125	0,25	7	SCM830-2500Z07R-F0025HA5-HP209	30936154

Edge design with sharp edge | Preferred series in stock

8,00	8	81	40	-	7	SCM830-0800Z07R-S-HA5-HP209	31046449
10,00	10	96	50	-	7	SCM830-1000Z07R-S-HA5-HP209	31046470
12,00	12	112	60	-	7	SCM830-1200Z07R-S-HA5-HP209	31046471
14,00	14	122	70	-	7	SCM830-1400Z07R-S-HA5-HP209	31046473
16,00	16	136	80	-	7	SCM830-1600Z07R-S-HA5-HP209	31046474
20,00	20	160	100	-	7	SCM830-2000Z07R-S-HA5-HP209	31046476

Design with sharp edge | Available on request

18,00	18	147	90	-	7	SCM830-1800Z07R-S-HA5-HP209	31046475
25,00	25	195	125	-	7	SCM830-2500Z07R-S-HA5-HP209	31046477

Configurable features



Shank form:
Shank form: HB



Specification:

SCM830-0800Z07R-F0008[shank form]5-HP209

Example:

SCM830-0800Z07R-F0008HB5-HP209

Shank form HB

Dimensions in mm.

For cutting data recommendations, see end of chapter.

Special designs and other coatings available upon request.

OptiMill®-Uni-HPC-Finish

Shoulder milling cutter, long design with neck
SCM370

Design:

Diameter of milling cutter: 6.00 - 20.00 mm
Cutting material: HP213
Number of cutting edges: 6
Helix angle: 39°/41°
Special features: Unequal spacing

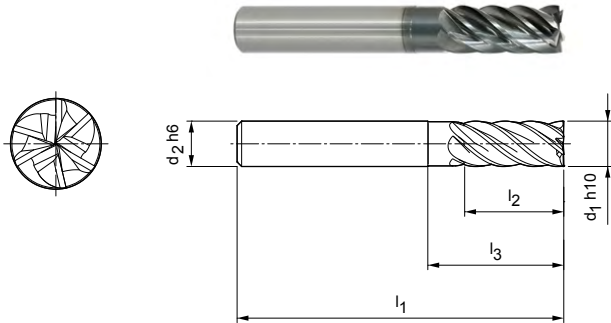

Preferred series in stock

Dimensions					z	Specification	Order no.
d ₁ h10	d ₂ h6	l ₁	l ₂	l ₃			
6,00	6	57	15	20	6	SCM370-0600Z06R-S-HA-HP213	30393541
8,00	8	63	21	25	6	SCM370-0800Z06R-S-HA-HP213	30393542
10,00	10	72	22	30	6	SCM370-1000Z06R-S-HA-HP213	30393543
12,00	12	83	26	36	6	SCM370-1200Z06R-S-HA-HP213	30393544
16,00	16	92	36	42	6	SCM370-1600Z06R-S-HA-HP213	30393545
20,00	20	104	41	55	6	SCM370-2000Z06R-S-HA-HP213	30393546

Configurable features



Shank form:
Shank form: HB



Specification:
SCM370-0600Z06R-S-[shank form]-HP213

Example:

SCM370-0600Z06R-S-**HB**-HP213

Shank form HB

Dimensions in mm.

For cutting data recommendations, see end of chapter.

Special designs and other coatings available upon request.

CPMill®-Uni-HPC-Finish

Shoulder milling cutter, design with CFS connection
CPM130

Design:

Diameter of milling cutter: 8.00 – 25.00 mm
Cutting material: HP383
Number of cutting edges: 6
Helix angle: 45°
Special features: Unequal spacing

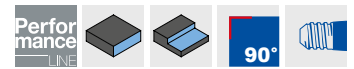
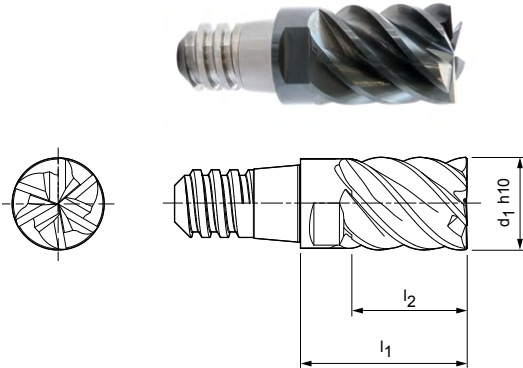

Preferred series in stock

Dimensions				z	a _p max.	SW	Specification	Order no.
d ₁ h10	CFS size	l ₁	l ₂					
8,00	6	15	10	6	7,5	SW 6	CPM130-0800Z06-S-06-HP383	30371380
10,00	8	18	12,5	6	9,4	SW 8	CPM130-1000Z06-S-08-HP383	30371381
12,00	10	22	15	6	11,3	SW 10	CPM130-1200Z06-S-10-HP383	30371382
16,00	12	28	20	6	15	SW 13	CPM130-1600Z06-S-12-HP383	30371383
20,00	16	35	25	6	18,8	SW 16	CPM130-2000Z06-S-16-HP383	30371386

Available on request

25,00	20	45	32	6	23,4	SW 21	CPM130-2500Z06-S-20-HP383	30371387
-------	----	----	----	---	------	-------	---------------------------	----------

Accessories

	CFS replaceable head holders CFS101 CFS201	Page 218
-------------------------------------------------------------------------------------	-------------------------------------------------	----------

Dimensions in mm.

For cutting data recommendations, see end of chapter.

Special designs and other coatings available upon request.

OptiMill®-Hardened-Finish

Shoulder milling cutter, 2xD design
SCM104

Design:

Diameter of milling cutter: 4.00 - 25.00 mm
Cutting material: HP808
Number of cutting edges: 6
Helix angle: 55°

Application:

For finishing of parts with a hardness of 45 HRC.

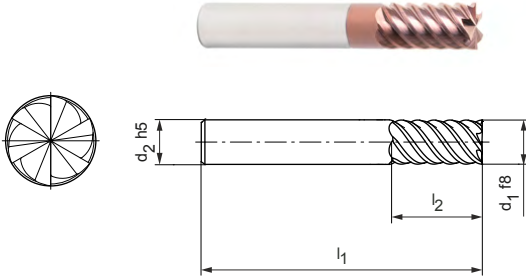

Design with sharp edge | Preferred series in stock

Dimensions					z	Specification	Order no.
d ₁ f8	d ₂ h5	l ₁	l ₂	R			
4,00	6	57	11	-	6	SCM104-0400Z06R-S-HA2-HP808	31152764
5,00	6	57	13	-	6	SCM104-0500Z06R-S-HA2-HP808	31152765
6,00	6	57	13	-	6	SCM104-0600Z06R-S-HA2-HP808	31152766
8,00	8	63	19	-	6	SCM104-0800Z06R-S-HA2-HP808	31152767
10,00	10	72	22	-	6	SCM104-1000Z06R-S-HA2-HP808	31152768
12,00	12	83	26	-	6	SCM104-1200Z06R-S-HA2-HP808	31152769
16,00	16	92	32	-	6	SCM104-1600Z06R-S-HA2-HP808	31152771

Design with sharp edge | Available on request

20,00	20	104	41	-	6	SCM104-2000Z06R-S-HA2-HP808	31152773
25,00	25	125	50	-	6	SCM104-2500Z06R-S-HA2-HP808	31152774

Design with corner radius | Preferred series in stock

4,00	6	57	11	0,5	6	SCM104-0400Z06R-R0050HA2-HP808	31199098
5,00	6	57	13	0,5	6	SCM104-0500Z06R-R0050HA2-HP808	31199099
5,00	6	57	13	1	6	SCM104-0500Z06R-R0100HA2-HP808	31199100
6,00	6	57	13	0,5	6	SCM104-0600Z06R-R0050HA2-HP808	31199101
6,00	6	57	13	1	6	SCM104-0600Z06R-R0100HA2-HP808	31199102
8,00	8	63	19	0,5	6	SCM104-0800Z06R-R0050HA2-HP808	31199103
8,00	8	63	19	1	6	SCM104-0800Z06R-R0100HA2-HP808	31199104
10,00	10	72	22	0,5	6	SCM104-1000Z06R-R0050HA2-HP808	31199105
10,00	10	72	22	1	6	SCM104-1000Z06R-R0100HA2-HP808	31199106
12,00	12	83	26	0,5	6	SCM104-1200Z06R-R0050HA2-HP808	31199107
12,00	12	83	26	1	6	SCM104-1200Z06R-R0100HA2-HP808	31199108
16,00	16	92	32	0,5	6	SCM104-1600Z06R-R0050HA2-HP808	31199109
16,00	16	92	32	1	6	SCM104-1600Z06R-R0100HA2-HP808	31199110
16,00	16	92	32	2	6	SCM104-1600Z06R-R0200HA2-HP808	31199111

Design with corner radius | Available on request

20,00	20	104	41	1	6	SCM104-2000Z06R-R0100HA2-HP808	31199112
25,00	20	104	41	2	6	SCM104-2500Z06R-R0200HA2-HP808	31199113

Configurable features



Shank form:
Shank form: HB



Example:
SCM104-0400Z06R-S-**HB**4-HP808

Shank form HB

Specification:

SCM104-0400Z06R-S-[shank form]2-HP808

Dimensions in mm.

For cutting data recommendations, see end of chapter.

Special designs and other coatings available upon request.

OptiMill®-Hardened-Finish

Shoulder milling cutter, 3xD design
SCM104

Design:

Diameter of milling cutter: 4.00 - 25.00 mm
Cutting material: HP808
Number of cutting edges: 6
Helix angle: 55°

Application:

For finishing of parts with a hardness of 45 HRC.

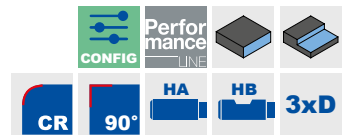
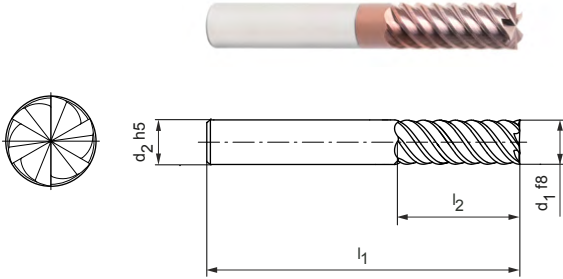

Design with sharp edge | Preferred series in stock

Dimensions					z	Specification	Order no.
d ₁ f8	d ₂ h5	l ₁	l ₂	R			
4,00	6	62	16	-	6	SCM104-0400Z06R-S-HA3-HP808	31152775
5,00	6	62	17	-	6	SCM104-0500Z06R-S-HA3-HP808	31152776
6,00	6	62	18	-	6	SCM104-0600Z06R-S-HA3-HP808	31152777
8,00	8	68	24	-	6	SCM104-0800Z06R-S-HA3-HP808	31152778
10,00	10	80	30	-	6	SCM104-1000Z06R-S-HA3-HP808	31152779
12,00	12	93	36	-	6	SCM104-1200Z06R-S-HA3-HP808	31152780
16,00	16	108	48	-	6	SCM104-1600Z06R-S-HA3-HP808	31152782

Design with sharp edge | Available on request

20,00	20	126	60	-	6	SCM104-2000Z06R-S-HA3-HP808	31152785
25,00	25	150	75	-	6	SCM104-2500Z06R-S-HA3-HP808	31152786

Design with corner radius | Preferred series in stock

4,00	6	62	16	0,5	6	SCM104-0400Z06R-R0050HA3-HP808	31199114
5,00	6	62	17	0,5	6	SCM104-0500Z06R-R0050HA3-HP808	31199115
5,00	6	62	17	1	6	SCM104-0500Z06R-R0100HA3-HP808	31199116
6,00	6	62	18	0,5	6	SCM104-0600Z06R-R0050HA3-HP808	31199117
6,00	6	62	18	1	6	SCM104-0600Z06R-R0100HA3-HP808	31199118
8,00	8	68	24	0,5	6	SCM104-0800Z06R-R0050HA3-HP808	31199119
8,00	8	68	24	1	6	SCM104-0800Z06R-R0100HA3-HP808	31199120
10,00	10	80	30	0,5	6	SCM104-1000Z06R-R0050HA3-HP808	31199121
10,00	10	80	30	1	6	SCM104-1000Z06R-R0100HA3-HP808	31199122
12,00	12	93	36	0,5	6	SCM104-1200Z06R-R0050HA3-HP808	31199123
12,00	12	93	36	1	6	SCM104-1200Z06R-R0100HA3-HP808	31199124
16,00	16	108	48	0,5	6	SCM104-1600Z06R-R0050HA3-HP808	31199125
16,00	16	108	48	1	6	SCM104-1600Z06R-R0100HA3-HP808	31199126
16,00	16	108	48	2	6	SCM104-1600Z06R-R0200HA3-HP808	31199127

Design with corner radius | Available on request

20,00	20	126	60	1	6	SCM104-2000Z06R-R0100HA2-HP808	31199128
20,00	20	126	60	2	6	SCM104-2000Z06R-R0200HA2-HP808	31199129

Configurable features



Shank form:
Shank form: HB

**Specification:**

SCM104-0400Z06R-S-[shank form]3-HP808

Example:

SCM104-0400Z06R-S-**HB3**-HP808

Shank form HB

Dimensions in mm.

For cutting data recommendations, see end of chapter.

Special designs and other coatings available upon request.

OptiMill®-Hardened-Finish

Shoulder milling cutter, extra long design with neck
SCM124

Design:

Diameter of milling cutter: 6.00 - 20.00 mm
Cutting material: HP808
Number of cutting edges: 6
Helix angle: 55°

Application:

For finishing of parts with a hardness of 45 HRC.

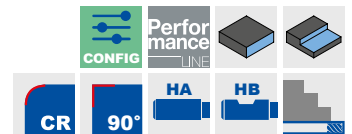
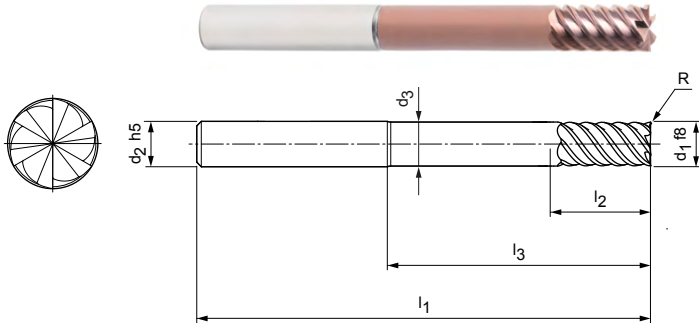

Design with sharp edge | Preferred series in stock

Dimensions							z	Specification	Order no.
d ₁ f8	d ₂ h5	d ₃	l ₁	l ₂	l ₃	R			
6,00	6	5,8	80	13	42	-	6	SCM124-0600Z06R-S-HA-HP808	31199092
8,00	8	7,8	100	21	62	-	6	SCM124-0800Z06R-S-HA-HP808	31199093
10,00	10	9,7	100	22	58	-	6	SCM124-1000Z06R-S-HA-HP808	31199094
12,00	12	11,7	120	26	73	-	6	SCM124-1200Z06R-S-HA-HP808	31199095
16,00	16	15,6	150	36	100	-	6	SCM124-1600Z06R-S-HA-HP808	31199096

Design with sharp edge | Available on request

20,00	20	19,5	150	41	98	-	6	SCM124-2000Z06R-S-HA-HP808	31199097
-------	----	------	-----	----	----	---	---	----------------------------	----------

Design with corner radius | Preferred series in stock

6,00	6	5,8	80	13	42	0,5	6	SCM124-0600Z06R-R0050HA-HP808	31199130
6,00	6	5,8	80	13	42	1	6	SCM124-0600Z06R-R0100HA-HP808	31199131
8,00	8	7,8	100	21	62	0,5	6	SCM124-0800Z06R-R0050HA-HP808	31199132
8,00	8	7,8	100	21	62	1	6	SCM124-0800Z06R-R0100HA-HP808	31199133
10,00	10	9,7	100	22	58	0,5	6	SCM124-1000Z06R-R0050HA-HP808	31199134
10,00	10	9,7	100	22	58	1	6	SCM124-1000Z06R-R0100HA-HP808	31199135
12,00	12	11,7	120	26	73	0,5	6	SCM124-1200Z06R-R0050HA-HP808	31199136
12,00	12	11,7	120	26	73	1	6	SCM124-1200Z06R-R0100HA-HP808	31199137
16,00	16	15,6	150	36	100	0,5	6	SCM124-1600Z06R-R0050HA-HP808	31199138
16,00	16	15,6	150	36	100	1	6	SCM124-1600Z06R-R0100HA-HP808	31199139
16,00	16	15,6	150	36	100	2	6	SCM124-1600Z06R-R0200HA-HP808	31199140

Design with corner radius | Available on request

20,00	20	19,5	150	41	98	1	6	SCM124-2000Z06R-R0100HA-HP808	31199141
20,00	20	19,5	150	41	98	2	6	SCM124-2000Z06R-R0200HA-HP808	31199142

Configurable features

Shank form:
Shank form: HB

Specification:
SCM124-0600Z06R-S-[shank form]-HP808

Example:

SCM124-0600Z06R-S-HB-HP808

Shank form HB

Dimensions in mm.

For cutting data recommendations, see end of chapter.

Special designs and other coatings available upon request.

OptiMill®-SPM-Finish

Shoulder milling cutter, 4xD design
SCM970

Design:

Diameter of milling cutter: 12.00 - 25.00 mm
Cutting material: HU019
Number of cutting edges: 4
Helix angle: 31°

Application:

Finishing of structural parts made of aluminium. Machining of deep pockets and delicate component structures even with large wrappings without "pull effect" (for example at the pocket corners).

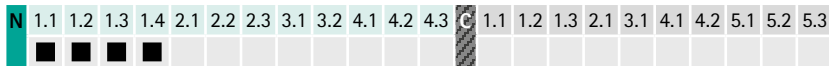
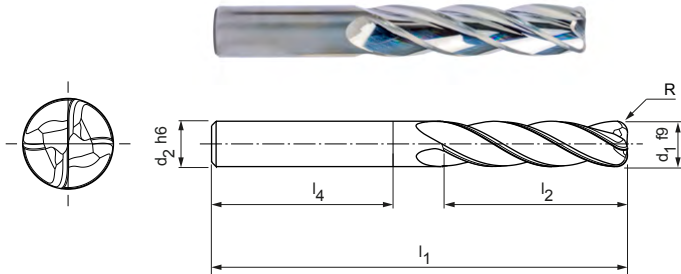

Metric dimensions | Preferred series in stock

Dimensions						z	Specification	Order no.
d ₁ f9	d ₂ h6	l ₁	l ₂	l ₄	R			
12,00	12	100	48	45	2	4	SCM970-1200Z04R-R0200HA-HU019	31111852
12,00	12	100	48	45	3	4	SCM970-1200Z04R-R0300HA-HU019	31082278
16,00	16	123	64	48	3	4	SCM970-1600Z04R-R0300HA-HU019	31082280
16,00	16	123	64	48	4	4	SCM970-1600Z04R-R0400HA-HU019	31082281
20,00	20	140	80	50	3	4	SCM970-2000Z04R-R0300HA-HU019	31082283
20,00	20	140	80	50	4	4	SCM970-2000Z04R-R0400HA-HU019	31082284

Metric dimensions | Available upon request

25,00	25	170	100	56	3	4	SCM970-2500Z04R-R0300HA-HU019	31082285
25,00	25	170	100	56	3	4	SCM970-2500Z04R-R0300HB-HU019	31190883

Inch dimensions | Available upon request

1/2"	1/2"	4"	2"	1,771"	0,12"	4	SCM970-1270Z04R-R0300HA-HU019	31082279
3/4"	3/4"	5 1/2"	3"	1,968"	0,12"	4	SCM970-1905Z04R-R0300HA-HU019	31082282

Configurable features



Shank form:
Shank form: HB



Specification:

SCM970-1200Z04R-R0200[shank form]-HU019

Example:

SCM970-1200Z04R-R0200HB-HU019

Shank form HB

Dimensions in mm.

For cutting data recommendations, see end of chapter.

Special designs and other coatings available upon request.

Cutting data recommendations for shoulder milling cutters

Feed and cutting speed

Finishing

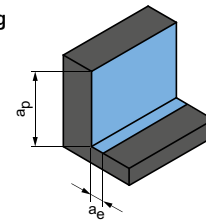

$$a_p = 1.5 \times D$$

$$a_e = 0.1 \times D$$

OptiMill-Uni-HPC-Finish | SCM370, 830

MMG*	Workpiece material			Strength/ hardness [N/mm ²] [HRC]	Cooling			v _c [m/ min]	f _z [mm]							
					MQL/Air	Dry	Coolant		Diameter of milling cutter [mm]							
									4.00	6.00	8.00	10.00	12.00	16.00	20.00	25.00
P	P1	P1.1	Structural, free-cutting, case hardened and heat-treated steels, non-alloy	< 700	✓	✓	✓	385	0.042	0.06	0.077	0.093	0.106	0.13	0.149	0.166
		P1.2	Structural, free-cutting, case hardened and heat-treated steels, non-alloy	< 1200	✓	✓	✓	315	0.039	0.056	0.072	0.086	0.099	0.121	0.139	0.155
	P2	P2.1	Nitrided, case hardened and heat-treated steels, alloy	< 900	✓	✓	✓	350	0.042	0.06	0.077	0.093	0.106	0.13	0.149	0.166
		P2.2	Nitrided, case hardened and heat-treated steels, alloy	< 1400	✓	✓	✓	245	0.035	0.05	0.064	0.077	0.089	0.108	0.124	0.138
	P3	P3.1	Tool, bearing, spring and high-speed steels**	< 800	✓	✓	✓	225	0.041	0.058	0.075	0.089	0.103	0.126	0.144	0.16
		P3.2	Tool, bearing, spring and high-speed steels**	< 1000	✓	✓	✓	210	0.039	0.055	0.071	0.085	0.097	0.119	0.136	0.152
		P3.3	Tool, bearing, spring and high-speed steels**	< 1500	✓	✓	✓	190	0.036	0.052	0.067	0.08	0.092	0.113	0.129	0.144
	P4	P4.1	Stainless steels, ferritic and martensitic		✓	✓	✓	155	0.028	0.04	0.052	0.062	0.071	0.087	0.099	0.11
	P5	P5.1	Cast steel				✓	235	0.041	0.058	0.075	0.089	0.103	0.126	0.144	0.16
P6	P6.1	Stainless cast steel, ferritic and martensitic				✓	155	0.02	0.028	0.036	0.043	0.05	0.061	0.069	0.077	
M	M1	M1.1	Stainless steels, austenitic	< 700	✓	✓	✓	130	0.025	0.035	0.045	0.054	0.062	0.076	0.087	0.097
		M1.2	Stainless steels, ferritic/austenitic (duplex)	< 1000			✓	120	0.02	0.029	0.037	0.045	0.051	0.063	0.072	0.08
	M2	M2.1	Stainless/heat-resistant cast steel, austenitic	< 700	✓	✓	✓	145	0.027	0.038	0.049	0.059	0.067	0.082	0.094	0.105
	M3	M3.1	Stainless cast steel, ferritic/austenitic (duplex)	< 1000			✓	130	0.021	0.03	0.039	0.046	0.053	0.065	0.074	0.083
K	K1	K1.1	Cast iron with lamellar graphite (grey cast iron), GJL	< 300	✓	✓	✓	520	0.07	0.101	0.129	0.154	0.177	0.216	0.248	0.276
		K2.1	Cast iron with spheroidal graphite, GJS	< 500	✓	✓	✓	475	0.06	0.086	0.109	0.131	0.151	0.184	0.21	0.235
	K2	K2.2	Cast iron with spheroidal graphite, GJS	≤ 800	✓	✓	✓	390	0.049	0.071	0.09	0.108	0.124	0.152	0.173	0.193
		K2.3	Cast iron with spheroidal graphite, GJS	> 800	✓	✓	✓	215	0.028	0.04	0.052	0.062	0.071	0.087	0.099	0.11
	K3	K3.1	Cast iron with spheroidal graphite, GJV; malleable cast iron, GJM	< 500	✓	✓	✓	345	0.049	0.071	0.09	0.108	0.124	0.152	0.173	0.193
		K3.2	Cast iron with spheroidal graphite, GJV; malleable cast iron, GJM	> 500	✓	✓	✓	325	0.042	0.06	0.077	0.093	0.106	0.13	0.149	0.166
S	S1	S1.1	Titanium, titanium alloys	< 400			✓	135	0,021	0,030	0,038	0,046	0,052	0,064	0,073	0,082
		S2.1	Titanium, titanium alloys	< 1200			✓	120	0,017	0,024	0,031	0,037	0,043	0,052	0,060	0,067
	S2.2	Titanium, titanium alloys	> 1200			✓	80	0,015	0,022	0,028	0,033	0,038	0,047	0,053	0,059	

Version with chamfer

Factors for tool lengths 3xD/4xD/5xD ***

Max. machining depth a _p	a _e max.	Correction factors	
		v _c	f _z
3xD	0,1xD	0,9	0,9
4xD	0,05xD	0,9	0,7
5xD	0,05xD	0,8	0,6

Version with sharp edge

Factors for tool lengths 3xD/4xD/5xD ***

Max. machining depth a _p	a _e max.	Correction factors	
		v _c	f _z
3xD	0,05xD	0,9	0,9
4xD	0,03xD	0,9	0,7
5xD	0,03xD	0,8	0,6

* MAPAL machining groups

** If the alloy parts Cr, Mo, Ni, V, W in total > 8%, then select the next highest MAPAL machining group.

*** In order to achieve very good surface results, the feed rate must be reduced further.

The specified machining values are guide values.

The optimum data for the respective machining task should be determined during the test or machining.

Finishing

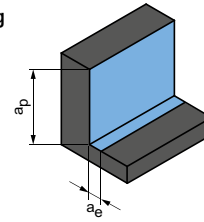

$$a_p = 0.94 \times D$$

$$a_e = 0.1 \times D$$

CPMill-Uni-HPC-Finish | CPM130

MMG*	Workpiece material		Strength/ hardness [N/mm ²] [HRC]	Cooling			v_c [m/min]	f_z [mm]						
				MQL/Air	Dry	Coolant		Diameter of milling cutter [mm]						
								8.00	10.00	12.00	16.00	20.00	25.00	
P	P1	P1.1	Structural, free-cutting, case hardened and heat-treated steels, non-alloy	< 700	✓	✓	✓	385	0.057	0.069	0.079	0.096	0.11	0.123
		P1.2	Structural, free-cutting, case hardened and heat-treated steels, non-alloy	< 1200	✓	✓	✓	315	0.054	0.064	0.074	0.09	0.103	0.115
	P2	P2.1	Nitrided, case hardened and heat-treated steels, alloy	< 900	✓	✓	✓	350	0.057	0.069	0.079	0.096	0.11	0.123
		P2.2	Nitrided, case hardened and heat-treated steels, alloy	< 1400	✓		✓	245	0.048	0.057	0.066	0.08	0.092	0.103
	P3	P3.1	Tool, bearing, spring and high-speed steels**	< 800	✓	✓	✓	225	0.055	0.066	0.076	0.093	0.107	0.119
		P3.2	Tool, bearing, spring and high-speed steels**	< 1000	✓		✓	210	0.053	0.063	0.072	0.088	0.101	0.113
		P3.3	Tool, bearing, spring and high-speed steels**	< 1500	✓		✓	190	0.05	0.06	0.068	0.084	0.096	0.107
P5	P5.1	Cast steel				✓	235	0.055	0.066	0.076	0.093	0.107	0.119	
K	K1	K1.1	Cast iron with lamellar graphite (grey cast iron), GJL	< 300	✓	✓	✓	520	0.096	0.114	0.132	0.161	0.184	0.205
		K2.1	Cast iron with spheroidal graphite, GJS	< 500	✓	✓	✓	475	0.081	0.097	0.112	0.137	0.156	0.174
	K2	K2.2	Cast iron with spheroidal graphite, GJS	≤ 800	✓	✓	✓	390	0.067	0.08	0.092	0.113	0.129	0.144
		K2.3	Cast iron with spheroidal graphite, GJS	> 800	✓	✓	✓	215	0.038	0.046	0.053	0.064	0.074	0.082
	K3	K3.1	Cast iron with spheroidal graphite, GJV; malleable cast iron, GJM	< 500	✓	✓	✓	345	0.067	0.08	0.092	0.113	0.129	0.144
		K3.2	Cast iron with spheroidal graphite, GJV; malleable cast iron, GJM	> 500	✓	✓	✓	325	0.057	0.069	0.079	0.096	0.11	0.123

* MAPAL machining groups

** If the alloy parts Cr, Mo, Ni, V, W in total > 8%, then select the next highest MAPAL machining group. The specified machining values are guide values.

The optimum data for the respective machining task should be determined during the test or machining.

Cutting data recommendations for shoulder milling cutters

Feed and cutting speed

OptiMill-Hardened-Finish | SCM104

MMG*	Workpiece material		Strength/hardness [N/mm ²] [HRC]	Cooling			
				Dry	Air/MQL	Coolant	
H	H1	H1.1	Hardened steel / cast steel	< 44	✓	✓	
		H1.2	Hardened steel / cast steel	< 55	✓	✓	
	H2	H2.1	Hardened steel / cast steel	< 60		✓	
		H2.2	Hardened steel / cast steel	< 65		✓	
		H2.3	Hardened steel / cast steel	< 68		✓	
	H3	H3.1	Wear-resistant cast/chill casting, GJN		✓	✓	

OptiMill-SPM-Finish | SCM970

MMG*	Workpiece material		Strength/hardness [N/mm ²] [HRC]	Cooling		
				MQL/Air	Dry	Coolant
N	N1	N1.1	Aluminium, non-alloy and alloy < 3 % Si	✓	✓	✓
		N1.2	Aluminium, alloy ≤ 7 % Si	✓	✓	✓
		N1.3	Aluminium, alloy > 7-12 % Si	✓	✓	✓
		N1.4	Aluminium, alloy > 12 % Si	✓	✓	✓

* MAPAL machining groups

** If the alloy parts Cr, Mo, Ni, V, W in total > 8%, then select the next highest MAPAL machining group.

Finishing

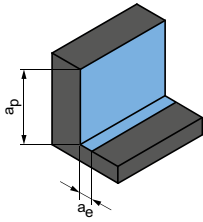

a_p [mm] in % of D	a_e [mm] in % of D	v_c [m/min]	f_z [mm]									
			Diameter of milling cutter [mm]									
			4.00	5.00	6.00	8.00	10.00	12.00	14.00	16.00	18.00	20.00
100	1.5	110 - 130	0.021	0.026	0.034	0.043	0.055	0.064	0.077	0.089	0.100	0.111
100	1.2	90 - 115	0.018	0.021	0.028	0.035	0.046	0.053	0.063	0.074	0.082	0.092
100	0.8	80 - 100	0.015	0.018	0.024	0.030	0.039	0.045	0.054	0.063	0.071	0.079
100	0.6	70 - 90	0.013	0.015	0.020	0.025	0.033	0.038	0.045	0.053	0.059	0.066
100	0.4	60 - 85	0.010	0.012	0.016	0.020	0.026	0.030	0.036	0.042	0.047	0.052
100	0.8	80 - 100	0.015	0.018	0.024	0.030	0.039	0.045	0.054	0.063	0.071	0.079

Finishing

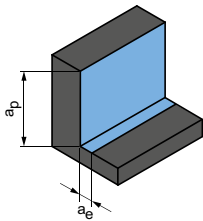

$a_p = 1xD$
 $a_e = 0.1xD$

$a_p = 1xD$
 $a_e = 0.1xD$

v_c [m/min]	f_z [mm]			
	Diameter of milling cutter [mm]			
	12.00	16.00	20.00	25.00
985	0.107	0.131	0.150	0.167
655	0.112	0.137	0.157	0.175
525	0.118	0.144	0.164	0.184
380	0.128	0.157	0.179	0.200

The specified machining values are guide values.
The optimum data for the respective machining task should be determined during the test or machining.





SHOULDER MILLING CUTTER – TROCHOIDAL MILLING

Universal application

OptiMill-Tro-Uni 152

Steel and stainless steel

OptiMill-Tro-PM 155

Hardened steel

OptiMill-Tro-H 160

Titanium and nickel-based alloys

OptiMill-Tro-S 161

OptiMill-Tro-Titan 162

Technical appendix

Cutting data recommendations 164

Application notes Trochoidal milling 402

OptiMill®-Tro-Uni

Shoulder milling cutter, 3xD design with neck, includes chip breaker
SCM580 | SCM940

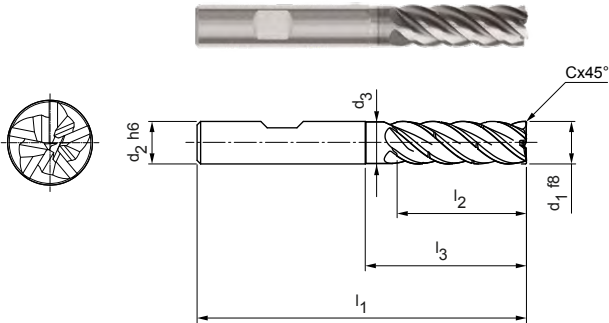

Design:

Diameter of milling cutter: 4.00 - 20.00 mm
 Cutting material: HP213
 Number of cutting edges: 5
 Helix angle: ~ 41°
 Balancing quality: Cutting edge portion balanced on G2.5 according to DIN ISO1940-G2.5
 Special features: Unequal spacing, chip breaker

Application:

Design with chip breaker for optimum chip control. Ensures chips are shortened.

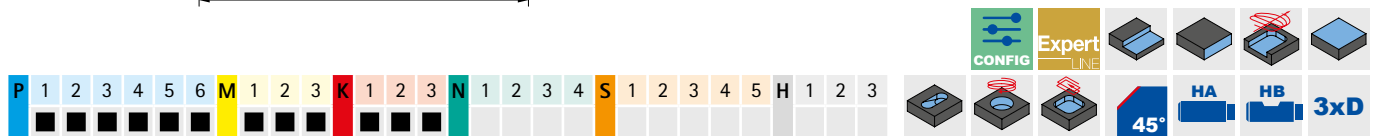

Preferred series in stock

Dimensions							z	Chip breaker	Specification	Order no.
d ₁ f8	d ₂ h6	d ₃	l ₁	l ₂	l ₃	Cx45°				
4,00	6	3,9	62	16	23	0,08	5	1	SCM580-0400Z05R-F0008HB3-HP213	30615710
5,00	6	4,8	62	17	24	0,10	5	1	SCM580-0500Z05R-F0010HB3-HP213	30564623
6,00	6	5,8	62	18	25	0,12	5	1	SCM580-0600Z05R-F0012HB3-HP213	30564624
8,00	8	7,8	68	24	30	0,16	5	1	SCM580-0800Z05R-F0016HB3-HP213	30564625
10,00	10	9,8	80	30	35	0,20	5	1	SCM580-1000Z05R-F0020HB3-HP213	30564626
12,00	12	11,8	93	36	45	0,24	5	2	SCM940-1200Z05R-F0024HB3-HP213	31054530
14,00	14	13,8	99	42	50	0,28	5	2	SCM940-1400Z05R-F0028HB3-HP213	31054531
16,00	16	15,8	108	48	55	0,32	5	2	SCM940-1600Z05R-F0032HB3-HP213	31054532
20,00	20	19,8	126	60	70	0,40	5	2	SCM940-2000Z05R-F0040HB3-HP213	31054533

Configurable features



Shank form:
Shank form: HA

Specification up to ø 10 mm:
SCM580-0400Z05R-F0008[shank form]-HP213

Specification from ø 12 mm:
SCM940-1200Z05R-F0024[shank form]3-HP213

Example:

SCM580-0400Z05R-F0008HA-HP213

Shank form HA

Dimensions in mm.

For cutting data recommendations, see end of chapter.

Special designs and other coatings available upon request.

OptiMill®-Tro-Uni

Shoulder milling cutter, 4xD design, with chip breaker
SCM940

Design:

Diameter of milling cutter: 5.00 - 20.00 mm
Cutting material: HP209
Number of cutting edges: 5
Helix angle: ~ 41°
Balancing quality: Cutting edge portion balanced on G2.5 according to DIN ISO 1940-G2.5
Special features: Unequal spacing, chip breaker

Application:

Design with chip breaker for optimum chip control. Ensures chips are shortened.

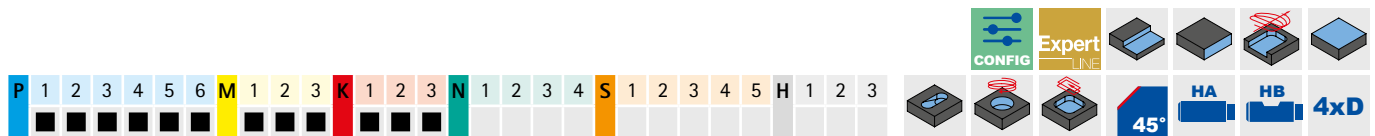
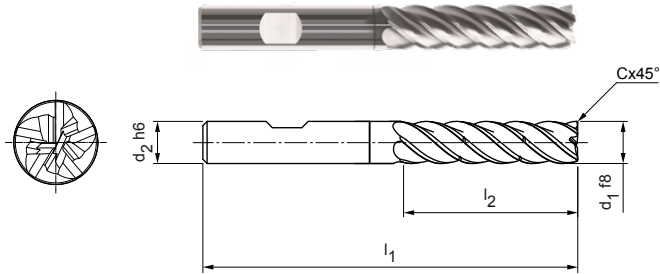

Preferred series in stock

Dimensions					z	Chip breaker	Specification	Order no.
d ₁ f8	d ₂ h6	l ₁	l ₂	Cx45°				
5,00	6	66	20	0,10	5	2	SCM940-0500Z05R-F0010HB4-HP209	31054534
6,00	6	66	24	0,12	5	2	SCM940-0600Z05R-F0012HB4-HP209	31054535
8,00	8	74	32	0,16	5	2	SCM940-0800Z05R-F0016HB4-HP209	31054536
10,00	10	89	40	0,20	5	2	SCM940-1000Z05R-F0020HB4-HP209	31054537
12,00	12	100	48	0,24	5	2	SCM940-1200Z05R-F0024HB4-HP209	31054538
16,00	16	123	64	0,32	5	2	SCM940-1600Z05R-F0032HB4-HP209	31054540
20,00	20	140	80	0,40	5	2	SCM940-2000Z05R-F0040HB4-HP209	31054541

Available on request

14,00	14	108	56	0,28	5	2	SCM940-1400Z05R-F0028HB4-HP209	31054539
-------	----	-----	----	------	---	---	--------------------------------	----------

Configurable features



Shank form:
Shank form: HA



Specification:

SCM940-0500Z05R-F0010[shank form]4-HP209

Example:

SCM940-0500Z05R-F0010HA4-HP209

Shank form HA

Dimensions in mm.

For cutting data recommendations, see end of chapter.

Special designs and other coatings available upon request.

OptiMill®-Tro-Uni

Shoulder milling cutter, 5xD design, with chip breaker
SCM940

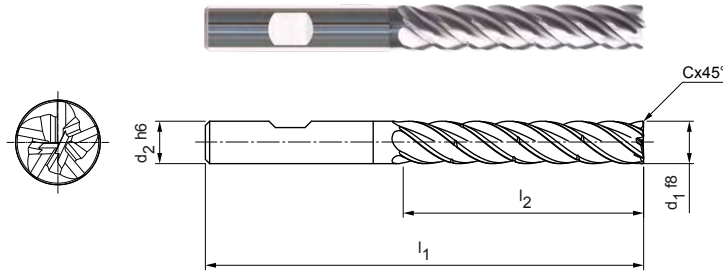

Design:

Diameter of milling cutter: 8.00 - 20.00 mm
 Cutting material: HP209
 Number of cutting edges: 5
 Helix angle: ~ 41°
 Balancing quality: Cutting edge portion balanced on G2.5 according to DIN ISO 1940-G2.5
 Special features: Unequal spacing, chip breaker

Application:

Design with chip breaker for optimum chip control. Ensures chips are shortened.

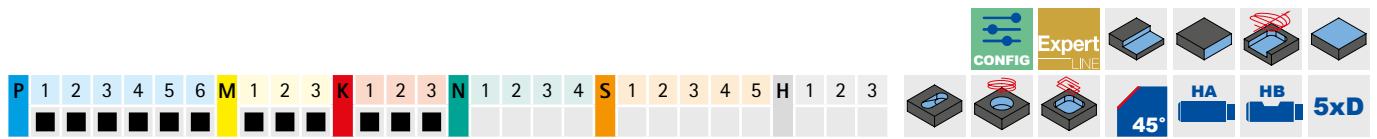

Preferred series in stock

Dimensions					z	Chip breaker	Specification	Order no.
d ₁ f8	d ₂ h6	l ₁	l ₂	Cx45°				
8,00	8	81	40	0,16	5	3	SCM940-0800Z05R-F0016HB5-HP209	31054542
10,00	10	96	50	0,20	5	3	SCM940-1000Z05R-F0020HB5-HP209	31054543
12,00	12	112	60	0,24	5	3	SCM940-1200Z05R-F0024HB5-HP209	31054544
16,00	16	136	80	0,32	5	3	SCM940-1600Z05R-F0032HB5-HP209	31054546
20,00	20	160	100	0,40	5	3	SCM940-2000Z05R-F0040HB5-HP209	31054547

Available on request

14,00	14	122	70	0,28	5	3	SCM940-1400Z05R-F0028HB5-HP209	31054545
-------	----	-----	----	------	---	---	--------------------------------	----------

Configurable features



Shank form:
Shank form: HA



Specification:
SCM940-0800Z05R-F0016[shank form]5-HP209

Example:

SCM940-0800Z05R-F0016**HA**5-HP209

Shank form HA

Dimensions in mm.

For cutting data recommendations, see end of chapter.

Special designs and other coatings available upon request.

OptiMill®-Tro-PM

Shoulder milling cutter, 3xD design with neck, includes chip breaker
SCM590

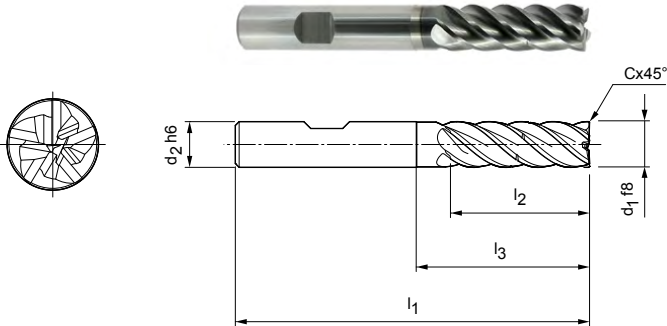

Design:

- Diameter of milling cutter: 4.00 - 25.00 mm
- Cutting material: HP723
- Number of cutting edges: 5
- Helix angle: 41° - 42°
- Balancing quality: Cutting edge portion balanced on G2.5 according to DIN ISO 1940-G2.5
- Special features: Unequal spacing, chip breaker

Application:

Design with chip breaker for optimum chip control. Ensures chips are shortened.

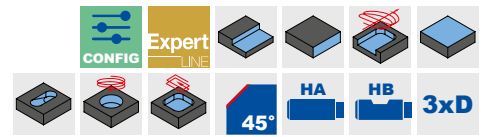

Preferred series in stock

Dimensions						z	Chip breaker	Specification	Order no.
d1 f8	d2 h6	l1	l2	l3	Cx45°				
4,00	6	62	16	23	0,08	5	1	SCM590-0400Z05R-F0008HB-HP723	30563364
5,00	6	62	17	24	0,10	5	1	SCM590-0500Z05R-F0010HB-HP723	30563365
6,00	6	62	18	25	0,12	5	1	SCM590-0600Z05R-F0012HB-HP723	30563366
8,00	8	68	24	30	0,16	5	1	SCM590-0800Z05R-F0016HB-HP723	30563367
10,00	10	80	30	35	0,20	5	1	SCM590-1000Z05R-F0020HB-HP723	30563368
12,00	12	93	36	45	0,24	5	1	SCM590-1200Z05R-F0024HB-HP723	30563369
14,00	14	99	42	50	0,28	5	1	SCM590-1400Z05R-F0028HB-HP723	30563370
16,00	16	108	48	55	0,32	5	1	SCM590-1600Z05R-F0032HB-HP723	30563371
18,00	18	117	54	67	0,36	5	1	SCM590-1800Z05R-F0036HB-HP723	30615879
20,00	20	126	60	70	0,40	5	1	SCM590-2000Z05R-F0040HB-HP723	30563372
25,00	25	150	75	92	0,50	5	1	SCM590-2500Z05R-F0050HB-HP723	30615113

Configurable features



Shank form:
Shank form: HA



Specification:
SCM590-0400Z05R-F0008[shank form]-HP723

Example:

SCM590-0400Z05R-F0008HA-HP723

Shank form HA

Dimensions in mm.

For cutting data recommendations, see end of chapter.

Special designs and other coatings available upon request.

OptiMill®-Tro-PM

Shoulder milling cutter, 2xD design with neck
SCM820

Design:

Diameter of milling cutter: 4.00 - 25.00 mm
 Cutting material: HP723
 Number of cutting edges: 7
 Helix angle: ~ 40°
 Balancing quality: Cutting edge portion balanced on G2.5 according to DIN ISO 1940-G2.5
 Special features: Unequal spacing

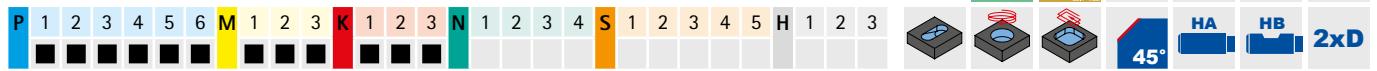
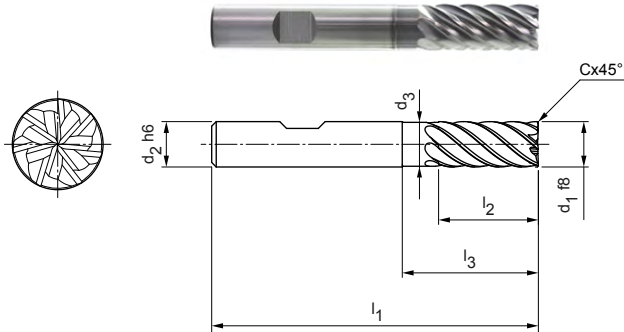

Preferred series in stock

Dimensions							z	Specification	Order no.
d1 f8	d2 h6	d3	l1	l2	l3	Cx45°			
4,00	6	-	57	11	-	0,08	7	SCM820-0400Z07R-F0008HB2-HP723	30855545
5,00	6	-	57	13	-	0,10	7	SCM820-0500Z07R-F0010HB2-HP723	30855546
6,00	6	5,8	57	13	19	0,12	7	SCM820-0600Z07R-F0012HB2-HP723	30855547
8,00	8	7,8	63	19	25	0,16	7	SCM820-0800Z07R-F0016HB2-HP723	30855548
10,00	10	9,8	72	22	30	0,20	7	SCM820-1000Z07R-F0020HB2-HP723	30855549
12,00	12	11,8	83	26	36	0,24	7	SCM820-1200Z07R-F0024HB2-HP723	30855550
16,00	16	15,8	92	32	42	0,32	7	SCM820-1600Z07R-F0032HB2-HP723	30855552
20,00	20	19,8	104	41	52	0,40	7	SCM820-2000Z07R-F0040HB2-HP723	30855554

Available on request

14,00	14	13,8	83	26	36	0,28	7	SCM820-1400Z07R-F0028HB2-HP723	30855551
18,00	18	17,8	92	32	42	0,36	7	SCM820-1800Z07R-F0036HB2-HP723	30855553
25,00	25	24,5	125	50	65	0,50	7	SCM820-2500Z07R-F0050HB2-HP723	30855555

Configurable features



Shank form:
Shank form: HA



Specification:
SCM820-0400Z07R-F0008[shank form]2-HP723

Example:

SCM820-0400Z07R-F0008HA2-HP723

Shank form HA

Dimensions in mm.

For cutting data recommendations, see end of chapter.

Special designs and other coatings available upon request.

OptiMill®-Tro-PM

Shoulder milling cutter, 3xD design with neck, includes chip breaker
SCM820 | SCM930

Design:

Diameter of milling cutter: 4.00 - 20.00 mm
Cutting material: HP723
Number of cutting edges: 7
Helix angle: ~ 40°
Balancing quality: Cutting edge portion balanced to G2.5 according to DIN ISO 1940-G2.5
Special features: Unequal spacing, chip breaker

Application:

Design with chip breaker for optimum chip control. Ensures chips are shortened.

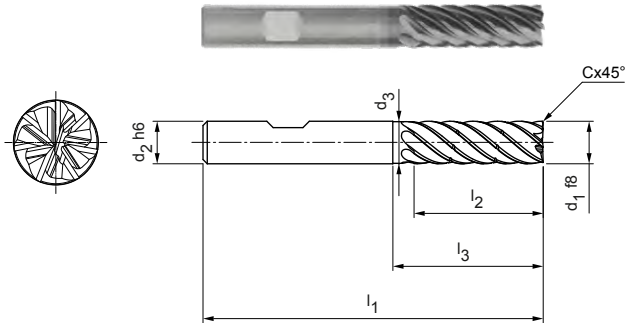

Preferred series in stock

Dimensions							z	Chip breaker	Specification	Order no.
d ₁ f8	d ₂ h6	d ₃	l ₁	l ₂	l ₃	Cx45°				
4,00	6	3,9	62	16	23	0,08	7	1	SCM820-0400Z07R-F0008HB3-HP723	30855556
5,00	6	4,8	62	17	24	0,10	7	1	SCM820-0500Z07R-F0010HB3-HP723	30855557
6,00	6	5,8	62	18	25	0,12	7	1	SCM820-0600Z07R-F0012HB3-HP723	30855558
8,00	8	7,8	68	24	30	0,16	7	1	SCM820-0800Z07R-F0016HB3-HP723	30855559
10,00	10	9,8	80	30	35	0,20	7	1	SCM820-1000Z07R-F0020HB3-HP723	30855560
12,00	12	11,8	93	36	45	0,24	7	2	SCM930-1200Z07R-F0024HB3-HP723	31054500
16,00	16	15,8	108	48	55	0,32	7	2	SCM930-1600Z07R-F0032HB3-HP723	31054502
20,00	20	19,8	126	60	70	0,40	7	2	SCM930-2000Z07R-F0040HB3-HP723	31054503

Available on request

14,00	14	13,8	99	42	50	0,28	7	2	SCM930-1400Z07R-F0028HB3-HP723	31054501
-------	----	------	----	----	----	------	---	---	--------------------------------	----------

Configurable features



Shank form:
Shank form: HA



Specification up to ø 10 mm:

SCM820-0400Z07R-F0008[shank form]3-HP723

Specification from ø 12 mm:

SCM930-1200Z07R-F0024[shank form]3-HP723

Example:

SCM820-0400Z07R-F0008HA3-HP723

Shank form HA

Dimensions in mm.

For cutting data recommendations, see end of chapter.

Special designs and other coatings available upon request.

OptiMill®-Tro-PM

Shoulder milling cutter, 4xD design, with chip breaker
SCM930

Design:

Diameter of milling cutter: 6.00 - 20.00 mm
Cutting material: HP210
Number of cutting edges: 7
Helix angle: ~ 38°
Special features: Unequal spacing, chip breaker

Application:

Design with chip breaker for optimum chip control. Ensures chips are shortened.

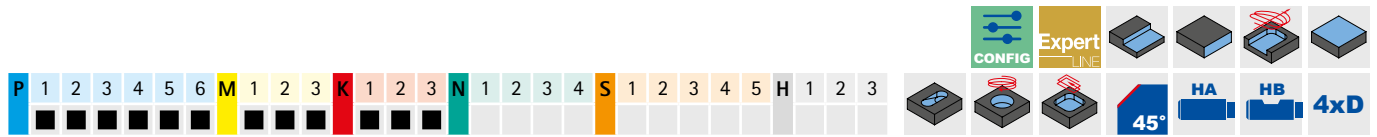
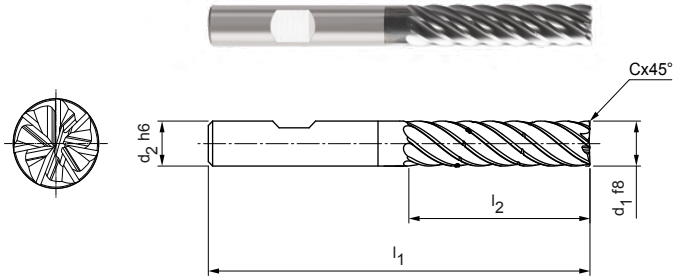

Preferred series in stock

Dimensions					z	Chip breaker	Specification	Order no.
d ₁ f8	d ₂ h6	l ₁	l ₂	Cx45°				
6,00	6	66	24	0,12	7	2	SCM930-0600Z07R-F0012HB4-HP210	31054505
8,00	8	74	32	0,16	7	2	SCM930-0800Z07R-F0016HB4-HP210	31054506
10,00	10	89	40	0,20	7	2	SCM930-1000Z07R-F0020HB4-HP210	31054507
12,00	12	100	48	0,24	7	2	SCM930-1200Z07R-F0024HB4-HP210	31054508
16,00	16	123	64	0,32	7	2	SCM930-1600Z07R-F0032HB4-HP210	31054510
20,00	20	140	80	0,40	7	2	SCM930-2000Z07R-F0040HB4-HP210	31054511

Available on request

14,00	14	108	56	0,28	7	2	SCM930-1400Z07R-F0028HB4-HP210	31054509
-------	----	-----	----	------	---	---	--------------------------------	----------

Configurable features

Shank form:
Shank form: HA

Specification:
SCM930-0600Z07R-F0012[shank form]4-H210

Example:

SCM930-0600Z07R-F0012**HA**4-HP210

Shank form HA

Dimensions in mm.

For cutting data recommendations, see end of chapter.

Special designs and other coatings available upon request.

OptiMill®-Tro-PM

Shoulder milling cutter, 5xD design, with chip breaker
SCM930

Design:

Diameter of milling cutter: 8.00 - 20.00 mm
Cutting material: HP210
Number of cutting edges: 7
Helix angle: ~ 36°
Special features: Unequal spacing, chip breaker

Application:

Design with chip breaker for optimum chip control. Ensures chips are shortened.

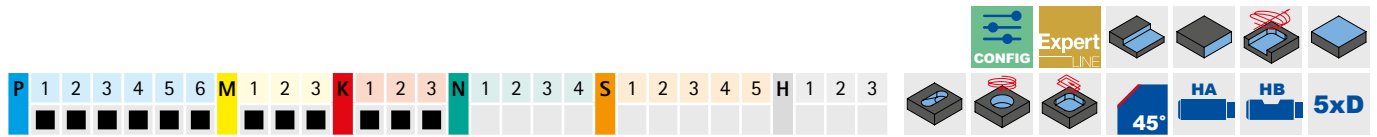
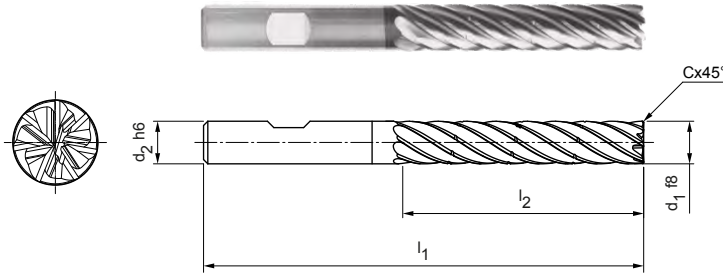

Preferred series in stock

Dimensions					z	Chip breaker	Specification	Order no.
d ₁ f8	d ₂ h6	l ₁	l ₂	Cx45°				
8,00	8	81	40	0,16	7	3	SCM930-0800Z07R-F0016HB5-HP210	31054512
10,00	10	96	50	0,20	7	3	SCM930-1000Z07R-F0020HB5-HP210	31054513
12,00	12	112	60	0,24	7	3	SCM930-1200Z07R-F0024HB5-HP210	31054514
16,00	16	136	80	0,32	7	3	SCM930-1600Z07R-F0032HB5-HP210	31054516
20,00	20	160	100	0,40	7	3	SCM930-2000Z07R-F0040HB5-HP210	31054517

Available on request

14,00	14	122	70	0,28	7	3	SCM930-1400Z07R-F0028HB5-HP210	31054515
-------	----	-----	----	------	---	---	--------------------------------	----------

Configurable features

Shank form:
Shank form: HA

Specification:
SCM590-0400Z05R-F0008[shank form]5-HP210

Example:

SCM590-0400Z05R-F0008HA5-HP210

Shank form HA

Dimensions in mm.

For cutting data recommendations, see end of chapter.

Special designs and other coatings available upon request.

OptiMill®-Tro-H

Shoulder milling cutter, 3xD design with neck, includes chip breaker
SCM920

Design:

Diameter of milling cutter: 6.00 - 25.00 mm
Cutting material: HP827
Number of cutting edges: 5
Helix angle: 41° - 42°
Balancing quality: Cutting edge portion balanced on G2.5 according to DIN ISO 1940-G2.5

Special features: Unequal spacing, chip breaker

Application:

Design with chip breaker for optimum chip control. Ensures chips are shortened.

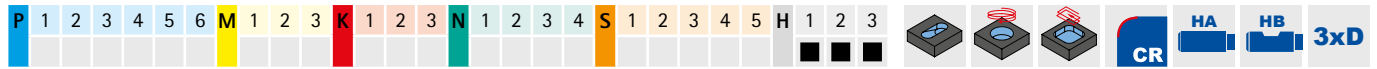
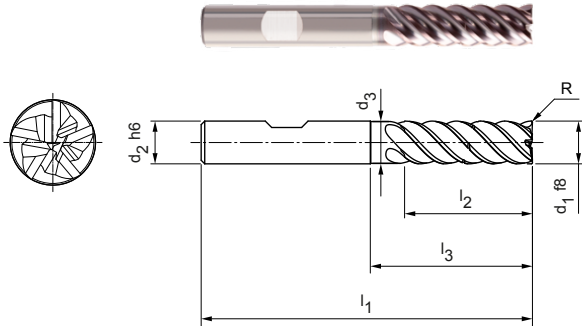

Preferred series in stock

Dimensions							z	Chip breaker	Specification	Order no.
d ₁ f8	d ₂ h6	d ₃	l ₁	l ₂	l ₃	R				
6,00	6	5,8	62	18	25	0,1	5	1	SCM920-0600Z05R-R0010HB-HP827	31053921
8,00	8	7,8	68	24	30	0,2	5	1	SCM920-0800Z05R-R0020HB-HP827	31053922
10,00	10	9,8	80	30	35	0,2	5	1	SCM920-1000Z05R-R0020HB-HP827	31053923
12,00	12	11,8	93	36	45	0,3	5	1	SCM920-1200Z05R-R0030HB-HP827	31053924
14,00	14	13,8	99	42	50	0,3	5	1	SCM920-1400Z05R-R0030HB-HP827	31053925
16,00	16	15,8	108	48	55	0,3	5	1	SCM920-1600Z05R-R0030HB-HP827	31053926
20,00	20	19,8	126	60	70	0,3	5	1	SCM920-2000Z05R-R0030HB-HP827	31053928

Available on request

18,00	18	17,8	117	54	67	0,3	5	1	SCM920-1800Z05R-R0030HB-HP827	31053927
25,00	25	24,5	150	75	92	0,4	5	1	SCM920-2500Z05R-R0040HB-HP827	31053929

Configurable features



Shank form:
Shank form: HA



Specification:
SCM920-0600Z05R-R0010[shank form]-HP827

Example:

SCM920-0600Z05R-R0010HA-HP827

Shank form HA

Dimensions in mm.

For cutting data recommendations, see end of chapter.

Special designs and other coatings available upon request.

OptiMill®-Tro-S

Shoulder milling cutter, design 3xD with neck
SCM600

Design:

Diameter of milling cutter: 6.00 - 25.00 mm
Cutting material: HP828
Number of cutting edges: 5
Helix angle: 41° - 42°
Balancing quality: Cutting edge portion balanced on G2.5 according to DIN ISO 1940-G2.5
Special features: Unequal spacing

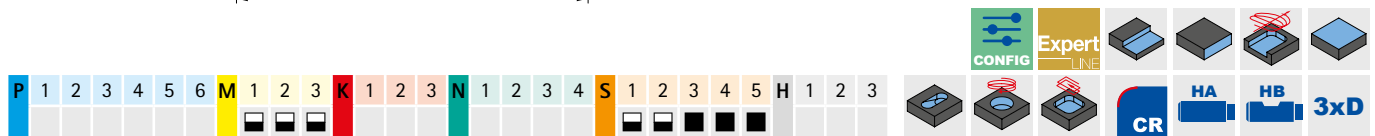
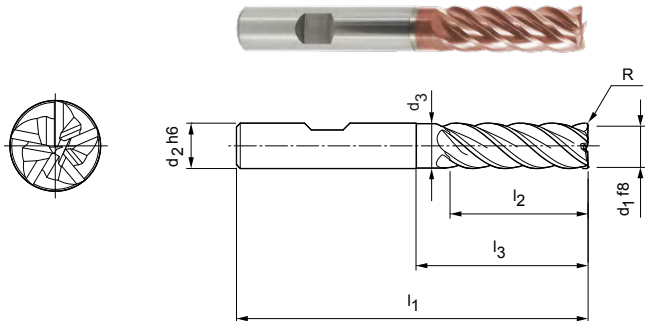

Preferred series in stock

Dimensions							z	Specification	Order no.
d ₁ f8	d ₂ h6	d ₃	l ₁	l ₂	l ₃	R			
6,00	6	5,8	62	18	25	0,1	5	SCM600-0600Z05R-R0010HB-HP828	30564634
8,00	8	7,8	68	24	30	0,2	5	SCM600-0800Z05R-R0020HB-HP828	30564635
10,00	10	9,8	80	30	35	0,2	5	SCM600-1000Z05R-R0020HB-HP828	30564636
12,00	12	11,8	93	36	45	0,3	5	SCM600-1200Z05R-R0030HB-HP828	30564637
16,00	16	15,8	108	48	55	0,3	5	SCM600-1600Z05R-R0030HB-HP828	30564639
20,00	20	19,8	126	60	70	0,3	5	SCM600-2000Z05R-R0030HB-HP828	30564640

Available on request

14,00	14	13,8	99	42	50	0,3	5	SCM600-1400Z05R-R0030HB-HP828	30564638
18,00	18	17,8	117	54	67	0,3	5	SCM600-1800Z05R-R0030HB-HP828	30605011
25,00	25	24,5	150	75	92	0,4	5	SCM600-2500Z05R-R0040HB-HP828	30605016

Configurable features

Shank form:
Shank form: HA

Specification:
SCM600-0600Z05R-R0010[shank form]-HP828

Example:

SCM600-0600Z05R-R0010HA-HP828

Shank form HA

Dimensions in mm.

For cutting data recommendations, see end of chapter.

Special designs and other coatings available upon request.

OptiMill®-Tro-Titan

Shoulder milling cutter, design 3xD with neck
SCM630

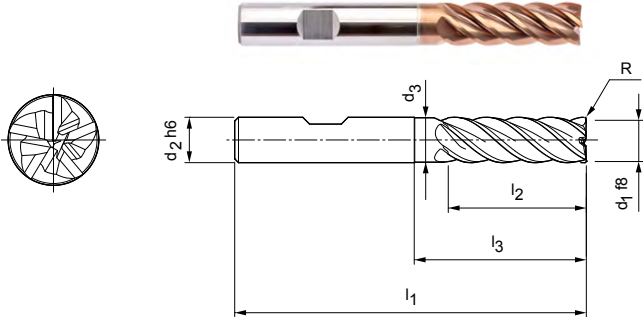

Design:

- Diameter of milling cutter: 6.00 - 25.00 mm
- Cutting material: HP826
- Number of cutting edges: 5
- Helix angle: 41° - 42°
- Balancing quality: Cutting edge portion balanced on G2.5 according to DIN ISO 1940-G2.5
- Special features: Unequal spacing

CONFIG Expert LINE

P 1 2 3 4 5 6 M 1 2 3 K 1 2 3 N 1 2 3 4 S 1 2 3 4 5 H 1 2 3

Preferred series in stock

Dimensions							z	Specification	Order no.
d ₁ f8	d ₂ h6	d ₃	l ₁	l ₂	l ₃	R			
6,00	6	5,8	62	18	25	0,1	5	SCM630-0600Z05R-R0010HB-HP826	30651032
8,00	8	7,8	68	24	30	0,2	5	SCM630-0800Z05R-R0020HB-HP826	30651033
10,00	10	9,8	80	30	35	0,2	5	SCM630-1000Z05R-R0020HB-HP826	30651034
12,00	12	11,8	93	36	45	0,3	5	SCM630-1200Z05R-R0030HB-HP826	30651035
16,00	16	15,8	108	48	55	0,3	5	SCM630-1600Z05R-R0030HB-HP826	30651037
20,00	20	19,8	126	60	70	0,3	5	SCM630-2000Z05R-R0030HB-HP826	30651039

Available on request

14,00	14	-	99	42	50	0,3	5	SCM630-1400Z05R-R0030HB-HP826	30651036
18,00	18	-	117	54	67	0,3	5	SCM630-1800Z05R-R0030HB-HP826	30651038
25,00	25	-	150	75	92	0,4	5	SCM630-2500Z05R-R0040HB-HP826	30651040

Configurable features

Shank form:
Shank form: HA

Specification:
SCM630-0600Z05R-R0010[shank form]-HP826

Example:

SCM630-0600Z05R-R0010HA-HP826

Shank form HA

Dimensions in mm.

For cutting data recommendations, see end of chapter.

Special designs and other coatings available upon request.



Cutting data recommendations for trochoidal milling cutters

Feed and cutting speed

Correction factors

Factor	v _c			a _e	h _m max.
	P	K	M		
2xD	1,10		1,05	1,05	1,05
3xD	1,00		1,00	1,00	1,00
4xD	0,85		0,92	0,90	0,94
5xD	0,60		0,80	0,80	0,87

OptiMill-Tro-Uni | SCM580, 940

OptiMill-Tro-PM | SCM590, 820, 930

MMG*	Workpiece material	Strength/hardness [N/mm ²] [HRC]	Cooling			
			MQL/Air	Dry	Coolant	
P	P1.1	Structural, free-cutting, case hardened and heat-treated steels, non-alloy	< 700	✓	✓	✓
	P1.2	Structural, free-cutting, case hardened and heat-treated steels, non-alloy	< 1200	✓	✓	✓
	P2.1	Nitrided, case hardened and heat-treated steels, alloy	< 900	✓	✓	✓
	P2.2	Nitrided, case hardened and heat-treated steels, alloy	< 1400	✓		✓
	P3.1	Tool, bearing, spring and high-speed steels**	< 800	✓	✓	✓
	P3.2	Tool, bearing, spring and high-speed steels**	< 1000	✓		✓
	P3.3	Tool, bearing, spring and high-speed steels**	< 1500	✓		✓
	P4.1	Stainless steels, ferritic and martensitic		✓		✓
	P5.1	Cast steel				
P6.1	Stainless cast steel, ferritic and martensitic				✓	
M	M1.1	Stainless steels, austenitic	< 700	✓		✓
	M1.2	Stainless steels, ferritic/austenitic (duplex)	< 1000			✓
	M2.1	Stainless/heat-resistant cast steel, austenitic	< 700	✓		✓
	M3.1	Stainless cast steel, ferritic/austenitic (duplex)	< 1000			✓
K	K1.1	Cast iron with lamellar graphite (grey cast iron), GJL	< 300	✓	✓	✓
	K2.1	Cast iron with spheroidal graphite, GJS	< 500	✓	✓	✓
	K2.2	Cast iron with spheroidal graphite, GJS	≤ 800	✓	✓	✓
	K2.3	Cast iron with spheroidal graphite, GJS	> 800	✓	✓	✓
	K3.1	Cast iron with spheroidal graphite, GJV; malleable cast iron, GJM	< 500	✓	✓	✓
	K3.2	Cast iron with spheroidal graphite, GJV; malleable cast iron, GJM	> 500	✓	✓	✓

Calculation example for 42CrMo4 ø 12 mm:

$$f_z | a_e | h_m \text{ max.} = \frac{D}{100} \cdot \text{See table for value}$$

P2.2	Nitrided, case hardened and heat-treated steels, alloy	< 1400	✓	✓	280 - 380	1.0 - 1.6	8 - 12	0.56 - 0.68
------	--------------------------------------------------------	--------	---	---	-----------	-----------	--------	-------------

$$1 \quad f_z = \frac{12 \text{ mm}}{100} \cdot 1,2 = 0,144 \text{ mm}$$

$$2 \quad a_e = \frac{12 \text{ mm}}{100} \cdot 10 = 1,2 \text{ mm}$$

$$3 \quad h_m \text{ max.} = \frac{12 \text{ mm}}{100} \cdot 0,6 = 0,072 \text{ mm}$$

Note:

In the case of trochoidal milling, the specified cutting conditions change during the machining process. This also depends on the CAM software used and the machining position of the tool in the workpiece. The feed and cutting width or contact angle are constantly changing during machining in order to achieve, as far as is possible, the most constant average chip thickness depending on the contour.

* MAPAL machining groups

** If the alloy parts Cr, Mo, Ni, V, W in total > 8%, then select the next highest MAPAL machining group.

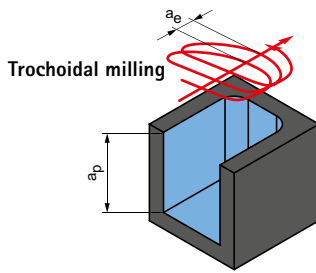

a_p = depending on max. machining depth of the tool
 a_e = depending on the workpiece material

v_c [m/min]	f_z [mm] in % of D	a_e [mm] in % of D	h_m max. [mm] in % of D	Machining example	
380 - 520	1.4 - 2.0	14 - 18	0.66 - 0.80	16MnCr5 $\varnothing = 12$ mm $v_c = 500$ m/min $f_z = 0.28$ mm $a_e = 1.8$ mm $a_p = 32$ mm	42CrMo4 $\varnothing = 12$ mm $v_c = 375$ m/min $f_z = 0.17$ mm $a_e = 1.2$ mm $a_p = 32$ mm
320 - 460	1.2 - 1.8	12 - 16	0.62 - 0.76		
340 - 480	1.2 - 1.8	10 - 14	0.58 - 0.71		
280 - 380	1.0 - 1.6	8 - 12	0.56 - 0.68		
250 - 360	1.1 - 1.7	9 - 15	0.56 - 0.67		
230 - 340	0.9 - 1.5	8 - 13	0.54 - 0.64		
210 - 320	0.8 - 1.4	6 - 12	0.52 - 0.62		
180 - 260	0.8 - 1.2	6 - 12	0.50 - 0.60		
220 - 300	1.2 - 1.8	8 - 12	0.54 - 0.62		
160 - 240	0.8 - 1.4	6 - 12	0.50 - 0.60	X5CrNi18-8 $\varnothing = 12$ mm $v_c = 180$ m/min $f_z = 0.09$ mm	$a_e = 1.2$ mm $a_p = 32$ mm
140 - 220	0.6 - 1.0	5 - 10	0.48 - 0.60		
110 - 180	0.6 - 1.0	5 - 10	0.46 - 0.58		
130 - 200	0.8 - 1.2	6 - 12	0.52 - 0.60		
120 - 180	0.8 - 1.2	5 - 10	0.46 - 0.56		
400 - 500	2.0 - 2.6	15 - 20	0.64 - 0.78		
340 - 500	1.8 - 2.4	12 - 16	0.62 - 0.7		
300 - 440	1.6 - 2.2	10 - 14	0.58 - 0.68		
180 - 260	1.4 - 2.0	8 - 12	0.56 - 0.68		
280 - 360	1.6 - 2.2	10 - 16	0.6 - 0.68		
210 - 340	1.4 - 2.0	10 - 16	0.58 - 0.66		

The specified machining values are guide values.

The optimum data for the respective machining task should be determined during the test or machining.

Cutting data recommendations for trochoidal milling cutters

Feed and cutting speed

OptiMill-Tro-H | SCM920

MMG*		Workpiece material	Strength/ hardness [N/mm ²] [HRC]	Cooling			v _c [m/min]	f _z [mm] in % of D	a _e [mm] in % of D	h _m max. [mm] in % of D
				MQL/Air	Dry	Coolant				
H	H1	H1.1	Hardened steel / cast steel	< 44	✓	✓	100 - 160	0.48 - 0.67	6 - 10	0.38 - 0.50
		H1.2	Hardened steel / cast steel	< 55	✓	✓	80 - 140	0.45 - 0.65	4 - 8	0.28 - 0.36
	H2	H2.1	Hardened steel / cast steel	< 60	✓	✓	60 - 120	0.4 - 0.52	3 - 6	0.27 - 0.34
		H2.2	Hardened steel / cast steel	< 65	✓	✓	50 - 110	0.37 - 0.5	3 - 5	0.26 - 0.33
		H2.3	Hardened steel / cast steel	< 68	✓	✓	50 - 100	0.3 - 0.48	2 - 5	0.25 - 0.32
H3	H3.1	Wear-resistant cast/chill casting, GJN		✓		60 - 120	0.35 - 0.55	3 - 6	0.28 - 0.34	

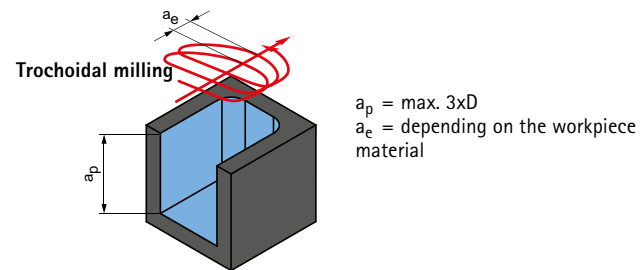

OptiMill-Tro-S | SCM600

OptiMill-Tro-Titan | SCM630

MMG*		Workpiece material	Strength/ hardness [N/mm ²] [HRC]	Cooling			v _c [m/min]	f _z [mm] in % of D	a _e [mm] in % of D	h _m max. [mm] in % of D	
				MQL/Air	Dry	Coolant					
S	S1	S1.1	Titanium, titanium alloys	< 400		✓	110 - 170	0.65 - 1.3	6 - 12	0.52 - 0.6	
		S2.1	Titanium, titanium alloys	< 1200		✓	90 - 150	0.6 - 1.2	5 - 10	0.46 - 0.56	
	S2	S2.2	Titanium, titanium alloys	> 1200		✓	70 - 130	0.4 - 1.0	5 - 10	0.42 - 0.54	
		S3	S3.1	Nickel, non-alloy and alloy	< 900		✓	60 - 120	0.4 - 1.0	5 - 10	0.4 - 0.52
			S3.2	Nickel, non-alloy and alloy	> 900		✓	50 - 100	0.3 - 0.9	5 - 10	0.4 - 0.52
	S4	S4.1	High-temperature super alloy Ni, Co and Fe-based			✓	35 - 90	0.3 - 0.8	4 - 8	0.38 - 0.46	
	S5	S5.1	Tungsten and molybdenum alloys			✓	35 - 90	0.3 - 0.8	4 - 8	0.38 - 0.46	

Note:

In the case of trochoidal milling, the specified cutting conditions change during the machining process. This also depends on the CAM software used and the machining position of the tool in the workpiece. The feed and cutting width or contact angle are constantly changing during machining in order to achieve, as far as is possible, the most constant average chip thickness depending on the contour.

	Machining example	
	90MnCrV8 $\varnothing = 12 \text{ mm}$ $v_c = 110 \text{ m/min}$ $f_z = 0.052 \text{ mm}$ $h_m = 0.04 \text{ mm}$ $a_e = 1 \text{ mm}$	

	Machining example	
	TiAl6V4 $\varnothing = 12 \text{ mm}$ $v_c = 140 \text{ m/min}$ $f_z = 0.09 \text{ mm}$ $a_e = 1.2 \text{ mm}$ $a_p = 30 \text{ mm}$	

The specified machining values are guide values.

The optimum data for the respective machining task should be determined during the test or machining.



HIGH-FEED MILLING

Universal application

OptiMill-3D-HF _____ 170

CPMill-Uni-FeedPlus _____ 172

Hardened steel

OptiMill-3D-HF-Hardened _____ 171

Technical appendix

Cutting data recommendations _____ 174



OptiMill®-3D-HF

High-feed milling cutter, design with neck
MHF101

Design:

Diameter of milling cutter: 3.00 - 16.00 mm
Cutting material: HP806
Number of cutting edges: 4
Helix angle: 5°

Application:

Especially for roughing of parts with a hardness of up to 55 HRC.

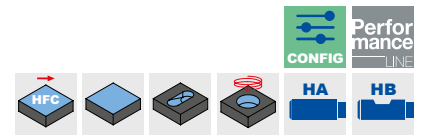
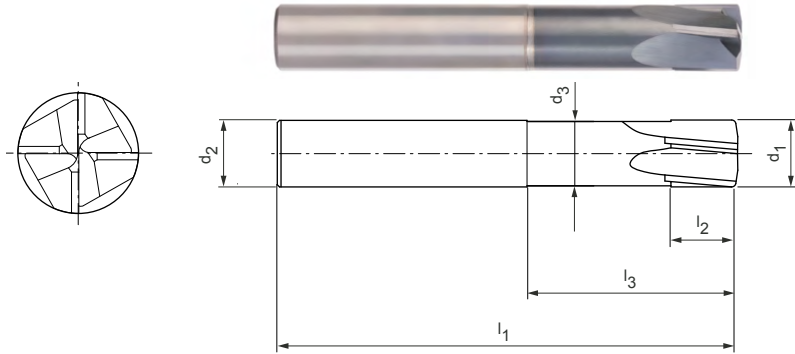

Preferred series in stock

Dimensions							z	ap max.	PRCAM	d _{min}	Shank form HA	
d ₁	R ₁	l ₃	d ₂ h6	l ₁	l ₂	d ₃					Specification	Order no.
3,00	0,15	9	4	50	3	2,85	4	0,13	0,2	1,5	MHF101-030-0200-0900X050-HP806	31150920
3,00	0,15	15	4	50	3	2,85	4	0,13	0,2	1,5	MHF101-030-0200-1500X050-HP806	31150921
3,00	0,15	9	6	60	3	2,85	4	0,13	0,2	1,5	MHF101-030-0200-0900X060-HP806	31150922
3,00	0,15	15	6	60	3	2,85	4	0,13	0,2	1,5	MHF101-030-0200-1500X060-HP806	31150923
4,00	0,2	12	6	60	4	3,8	4	0,17	0,3	2	MHF101-040-0300-1200X060-HP806	31150924
4,00	0,2	20	6	60	4	3,8	4	0,17	0,3	2	MHF101-040-0300-2000X060-HP806	31150925
5,00	0,25	15	6	60	5	4,75	4	0,2	0,4	2,3	MHF101-050-0400-1500X060-HP806	31150926
5,00	0,25	20	6	60	5	4,75	4	0,2	0,4	2,3	MHF101-050-0400-2000X060-HP806	31150927
6,00	0,3	18	6	60	6	5,7	4	0,24	0,5	3	MHF101-060-0500-1800X060-HP806	31150928
6,00	0,3	24	6	60	6	5,7	4	0,24	0,5	3	MHF101-060-0500-2400X060-HP806	31150929
8,00	0,4	24	8	64	8	7,7	4	0,31	0,7	3,8	MHF101-080-0700-2400X064-HP806	31150930
8,00	0,4	32	8	64	8	7,7	4	0,31	0,7	3,8	MHF101-080-0700-3200X064-HP806	31150931
8,00	0,4	40	8	75	8	7,7	4	0,31	0,7	3,8	MHF101-080-0700-4000X075-HP806	31150932
10,00	0,5	30	10	75	10	9,65	4	0,39	0,85	5	MHF101-100-0850-3000X075-HP806	31150933
10,00	0,5	40	10	75	10	9,65	4	0,39	0,85	5	MHF101-100-0850-4000X075-HP806	31150934
10,00	0,5	50	10	100	10	9,65	4	0,39	0,85	5	MHF101-100-0850-5000X100-HP806	31150935
12,00	0,6	36	12	75	12	11,6	4	0,46	1	5,8	MHF101-120-1000-3600X075-HP806	31150936
12,00	0,6	48	12	100	12	11,6	4	0,46	1	5,8	MHF101-120-1000-4800X100-HP806	31150937
12,00	0,6	60	12	100	12	11,6	4	0,46	1	5,8	MHF101-120-1000-6000X100-HP806	31150938
16,00	0,8	48	16	100	16	15,5	4	0,61	1,4	8	MHF101-160-1000-4800X100-HP806	31150939

Configurable features



Shank form:
Shank form: HB



Detailed view of face:

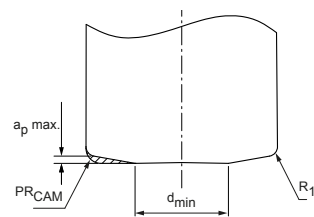

Dimensions in mm.

For cutting data recommendations, see end of chapter.

Special designs and other coatings available upon request.

OptiMill®-3D-HF-Hardened

High-feed milling cutter with innovative face geometry, design with neck
MHF102

Design:

Diameter of milling cutter: 2.00 - 16.00 mm
Cutting material: HP810
Number of cutting edges: 4
Helix angle: 12°
Special feature: Innovative face geometry

Application:

Especially for roughing and finishing of hardened parts with a hardness of 45 HRC or higher, as well as in interrupted cut. The innovative face geometry allows very good surface finishes to be achieved during finishing.

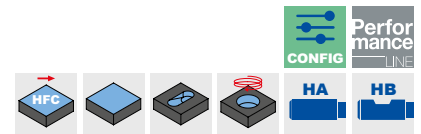
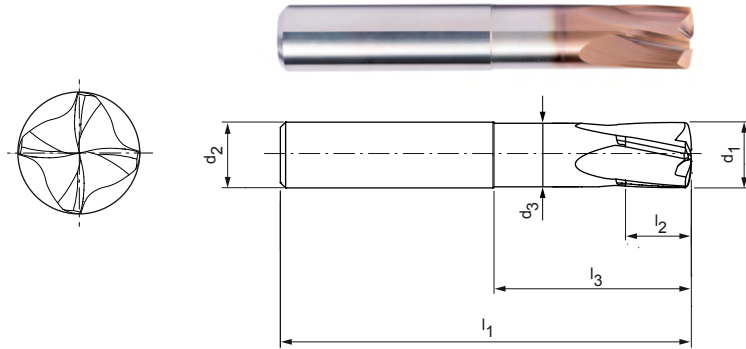

Preferred series in stock

Dimensions								z	a _p max.	PR _{CAM}	d _{min}	Shank form HA	
d ₁	R ₁	R ₂	l ₃	d ₂ h5	l ₁	l ₂	d ₃					Specification	Order no.
2,00	0,1	2,3	6	4	50	2	1,9	4	0,09	0,18	0,6	MHF102-020-0180-0600X050-HP810	31150940
2,00	0,1	2,3	10	4	50	2	1,9	4	0,09	0,18	0,6	MHF102-020-0180-1000X050-HP810	31150941
2,00	0,1	2,3	6	6	60	2	1,9	4	0,09	0,18	0,6	MHF102-020-0180-0600X060-HP810	31150942
2,00	0,1	2,3	10	6	60	2	1,9	4	0,09	0,18	0,6	MHF102-020-0180-1000X060-HP810	31150943
3,00	0,15	3,45	9	4	50	3	2,85	4	0,13	0,275	0,9	MHF102-030-0278-0900X050-HP810	31150944
3,00	0,15	3,45	15	4	50	3	2,85	4	0,13	0,275	0,9	MHF102-030-0275-1500X050-HP810	31150945
3,00	0,15	3,45	9	6	60	3	2,85	4	0,13	0,275	0,9	MHF102-030-0275-0900X060-HP810	31150946
3,00	0,15	3,45	15	6	60	3	2,85	4	0,13	0,275	0,9	MHF102-030-0275-1500X060-HP810	31150947
4,00	0,2	4,6	12	6	60	4	3,8	4	0,17	0,368	1,2	MHF102-040-0368-1200X060-HP810	31150948
4,00	0,2	4,6	20	6	60	4	3,8	4	0,17	0,368	1,2	MHF102-040-0368-2000X060-HP810	31150949
5,00	0,25	5,75	15	6	60	5	4,75	4	0,22	0,46	1,5	MHF102-050-0460-1500X060-HP810	31150950
5,00	0,25	5,75	20	6	60	5	4,75	4	0,22	0,46	1,5	MHF102-050-0460-2000X060-HP810	31150951
6,00	0,3	6,9	18	6	60	6	5,7	4	0,26	0,55	1,8	MHF102-060-0550-1800X060-HP810	31150952
6,00	0,3	6,9	24	6	60	6	5,7	4	0,26	0,55	1,8	MHF102-060-0550-2400X060-HP810	31150953
8,00	0,4	9,2	24	8	64	8	7,7	4	0,35	0,74	2,4	MHF102-080-0740-2400X064-HP810	31150954
8,00	0,4	9,2	32	8	64	8	7,7	4	0,35	0,74	2,4	MHF102-080-0740-3200X064-HP810	31150955
8,00	0,4	9,2	40	8	75	8	7,7	4	0,35	0,74	2,4	MHF102-080-0740-4000X075-HP810	31150956
10,00	0,5	11,5	30	10	75	10	9,65	4	0,44	0,92	3	MHF102-100-0920-3000X075-HP810	31150957
10,00	0,5	11,5	40	10	75	10	9,65	4	0,44	0,92	3	MHF102-100-0920-4000X075-HP810	31150958
10,00	0,5	11,5	50	10	100	10	9,65	4	0,44	0,92	3	MHF102-100-0920-5000X100-HP810	31150959
12,00	0,6	13,8	36	12	75	12	11,6	4	0,52	1,11	3,6	MHF102-120-1110-3600X075-HP810	31150960
12,00	0,6	13,8	48	12	100	12	11,6	4	0,52	1,11	3,6	MHF102-120-1110-4800X100-HP810	31150961
12,00	0,6	13,8	60	12	100	12	11,6	4	0,52	1,11	3,6	MHF102-120-1110-6000X100-HP810	31150962
16,00	0,8	18,4	48	16	100	16	15,5	4	0,7	1,47	4,8	MHF102-160-1470-4800X100-HP810	31150963

Configurable features

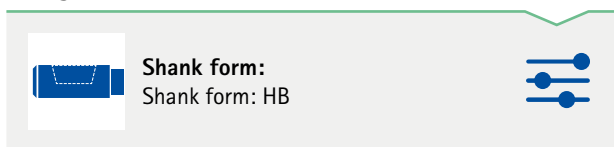

Detailed view of face:

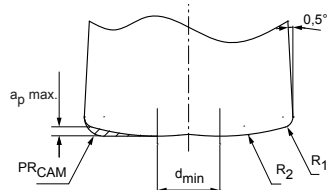

Dimensions in mm.

For cutting data recommendations, see end of chapter.

Special designs and other coatings available upon request.

CPMill®-Uni-FeedPlus

Design with CFS connection, with internal cooling
CPM171

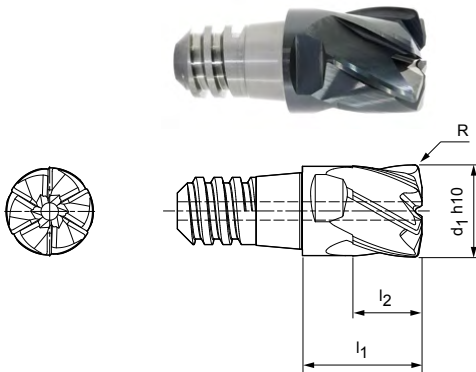

Design:

Diameter of milling cutter: 8.00 – 25.00 mm
Cutting material: HP383
Number of cutting edges: 6
Helix angle: 30°

Application:

High-feed milling with low a_p , angled entry and pocket milling with long projection lengths.

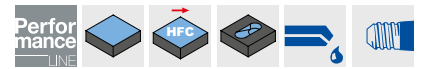

Preferred series in stock

					z	a_p max.	SW	Specification	Order no.
d_1 h10	CFS size	l_1	l_2	R					
8,00	6	11	6	0,4	6	0,4	SW 6	CPM171-0800Z06-R0040-06-HP383	30371359
10,00	8	13	7,5	0,5	6	0,5	SW 8	CPM171-1000Z06-R0050-08-HP383	30371360
12,00	10	16	9	0,6	6	0,6	SW 10	CPM171-1200Z06-R0060-10-HP383	30371361
16,00	12	20	12	0,8	6	0,8	SW 13	CPM171-1600Z06-R0080-12-HP383	30371362
20,00	16	25	15	1	6	1	SW 16	CPM171-2000Z06-R0100-16-HP383	30371364
25,00	20	32	19	1,25	6	1,25	SW 21	CPM171-2500Z06-R0125-20-HP383	30371365

Accessories

	CFS replaceable head holders CFS101 CFS201	Page 218
-------------------------------------------------------------------------------------	-------------------------------------------------	----------

Dimensions in mm.

For cutting data recommendations, see end of chapter.

Special designs and other coatings available upon request.

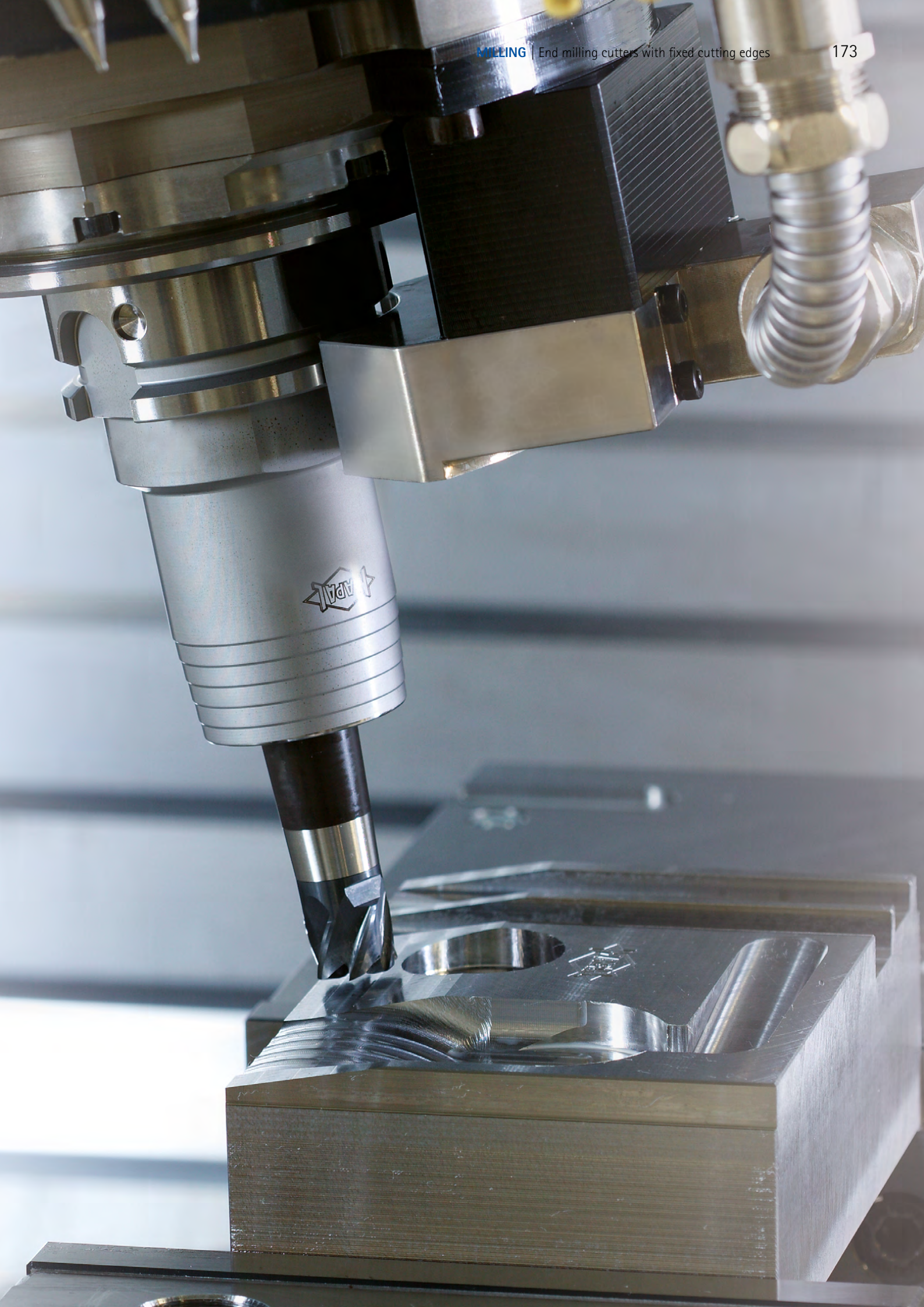

Cutting data recommendations for high-feed milling cutters

Feed and cutting speed

OptiMill-3D-HF | MHF101

MMG*		Workpiece material	Strength/hardness [N/mm ²] [HRC]	Cooling		
				MQL/Air	Dry	Coolant
P	P1	P1.1 Structural, free-cutting, case hardened and heat-treated steels, non-alloy	< 700	✓	✓	
		P1.2 Structural, free-cutting, case hardened and heat-treated steels, non-alloy	< 1200	✓	✓	
	P2	P2.1 Nitrided, case hardened and heat-treated steels, alloy	< 900	✓	✓	
		P2.2 Nitrided, case hardened and heat-treated steels, alloy	< 1400	✓	✓	
	P3	P3.1 Tool, bearing, spring and high-speed steels**	< 800	✓	✓	
		P3.2 Tool, bearing, spring and high-speed steels**	< 1000	✓	✓	
		P3.3 Tool, bearing, spring and high-speed steels**	< 1500	✓	✓	
	P4	P4.1 Stainless steels, ferritic and martensitic		✓		✓
	P5	P5.1 Cast steel		✓		✓
	P6	P6.1 Stainless cast steel, ferritic and martensitic		✓		✓
K	K1	K1.1 Cast iron with lamellar graphite (grey cast iron), GJL	< 300	✓	✓	
		K2.1 Cast iron with spheroidal graphite, GJS	< 500	✓	✓	
	K2	K2.2 Cast iron with spheroidal graphite, GJS	≤ 800	✓	✓	
		K2.3 Cast iron with spheroidal graphite, GJS	> 800	✓	✓	
	K3	K3.1 Cast iron with spheroidal graphite, GJV; malleable cast iron, GJM	< 500	✓	✓	
		K3.2 Cast iron with spheroidal graphite, GJV; malleable cast iron, GJM	> 500	✓	✓	
H	H1	H1.1 Hardened steel / cast steel	< 44	✓	✓	
		H1.2 Hardened steel / cast steel	< 55	✓	✓	
	H2	H2.1 Hardened steel / cast steel	< 60	✓	✓	

* MAPAL machining groups

** If the alloy parts Cr, Mo, Ni, V, W in total > 8%, then select the next highest MAPAL machining group.

Roughing

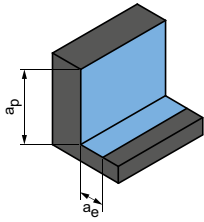

Plunge angle
1.0° - 1.5°

	a_p [mm] in % of D	a_e [mm] in % of D	v_c [m/min]	f_z [mm]								
				Diameter of milling cutter [mm]								
				2.00	3.00	4.00	5.00	6.00	8.00	10.00	12.00	16.00
	3.8	60	200 - 250	0.100	0.150	0.200	0.225	0.287	0.400	0.550	0.625	0.625
	3.8	60	150 - 200	0.100	0.150	0.200	0.225	0.287	0.400	0.550	0.625	0.625
	3.8	60	200 - 250	0.100	0.150	0.200	0.225	0.287	0.400	0.550	0.625	0.625
	3.8	65	150 - 200	0.100	0.150	0.200	0.225	0.287	0.400	0.550	0.625	0.625
	3.8	60	180 - 220	0.100	0.150	0.200	0.225	0.287	0.325	0.325	0.475	0.475
	3.8	65	150 - 180	0.100	0.150	0.200	0.225	0.287	0.325	0.325	0.475	0.475
	3.8	65	120 - 150	0.100	0.150	0.200	0.225	0.287	0.325	0.325	0.475	0.475
	3.8	60	90 - 110	0.100	0.150	0.200	0.225	0.287	0.325	0.325	0.475	0.475
	3.8	60	90 - 110	0.100	0.150	0.200	0.225	0.287	0.325	0.325	0.475	0.475
	3.8	60	70 - 90	0.100	0.150	0.200	0.225	0.287	0.325	0.325	0.475	0.475
	3.8	70	250 - 300	0.100	0.150	0.200	0.225	0.287	0.400	0.550	0.625	0.625
	3.8	70	250 - 300	0.100	0.150	0.200	0.225	0.287	0.400	0.550	0.625	0.625
	3.8	70	150 - 200	0.100	0.150	0.200	0.225	0.287	0.325	0.325	0.475	0.475
	3.8	70	150 - 200	0.100	0.150	0.200	0.225	0.287	0.325	0.325	0.475	0.475
	3.8	70	150 - 200	0.100	0.150	0.200	0.225	0.287	0.325	0.325	0.475	0.475
	3.8	70	150 - 200	0.100	0.150	0.200	0.225	0.287	0.325	0.325	0.475	0.475
	3.5	70	150 - 190	0.100	0.150	0.200	0.225	0.287	0.400	0.550	0.625	0.625
	3.2	65	120 - 150	0.100	0.150	0.200	0.225	0.287	0.325	0.325	0.475	0.475
	2.8	55	100 - 120	0.100	0.150	0.175	0.200	0.250	0.250	0.300	0.350	0.400

The specified machining values are guide values.

The optimum data for the respective machining task should be determined during the test or machining.

Cutting data recommendations for high-feed milling cutters

Feed and cutting speed

OptiMill-3D-HF-Hardened | MHF102, 103

MMG*	Workpiece material	Strength/hardness [N/mm ²] [HRC]	Cooling			
			MQL/Air	Dry	Coolant	
P	P1.1	Structural, free-cutting, case hardened and heat-treated steels, non-alloy	< 700	✓	✓	
	P1.2	Structural, free-cutting, case hardened and heat-treated steels, non-alloy	< 1200	✓	✓	
	P2.1	Nitrided, case hardened and heat-treated steels, alloy	< 900	✓	✓	
	P2.2	Nitrided, case hardened and heat-treated steels, alloy	< 1400	✓	✓	
	P3.1	Tool, bearing, spring and high-speed steels**	< 800	✓	✓	
	P3.2	Tool, bearing, spring and high-speed steels**	< 1000	✓	✓	
	P3.3	Tool, bearing, spring and high-speed steels**	< 1500	✓	✓	
	P4.1	Stainless steels, ferritic and martensitic		✓		✓
	P5.1	Cast steel		✓		✓
	P6.1	Stainless cast steel, ferritic and martensitic		✓		✓
K	K1.1	Cast iron with lamellar graphite (grey cast iron), GJL	< 300	✓	✓	
	K2.1	Cast iron with spheroidal graphite, GJS	< 500	✓	✓	
	K2.2	Cast iron with spheroidal graphite, GJS	≤ 800	✓	✓	
	K2.3	Cast iron with spheroidal graphite, GJS	> 800	✓	✓	
	K3.1	Cast iron with spheroidal graphite, GJV; malleable cast iron, GJM	< 500	✓	✓	
	K3.2	Cast iron with spheroidal graphite, GJV; malleable cast iron, GJM	> 500	✓	✓	
H	H1.1	Hardened steel / cast steel	< 44	✓	✓	
	H1.2	Hardened steel / cast steel	< 55	✓	✓	
	H2.1	Hardened steel / cast steel	< 60	✓		
	H2.2	Hardened steel / cast steel	< 65	✓		
	H2.3	Hardened steel / cast steel	< 68	✓		
	H3.1	Wear-resistant cast/chill casting, GJN		✓	✓	

OptiMill-3D-HF-Hardened | MHF102, 103

MMG*	Workpiece material	Strength/hardness [N/mm ²] [HRC]	Cooling		
			MQL/Air	Dry	Coolant
H2	H2.1	Hardened steel / cast steel	< 60	✓	
	H2.2	Hardened steel / cast steel	< 65	✓	
	H2.3	Hardened steel / cast steel	< 68	✓	
H3	H3.1	Wear-resistant cast/chill casting, GJN		✓	✓

* MAPAL machining groups

** If the alloy parts Cr, Mo, Ni, V, W in total > 8%, then select the next highest MAPAL machining group.

Roughing

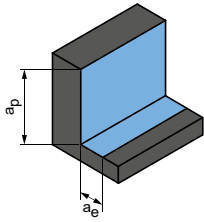

Plunge angle
1.0° - 1.5°

a_p [mm] in % of D	a_e [mm] in % of D	v_c [m/min]	f_z [mm]									
			Diameter of milling cutter [mm]									
			2.00	3.00	4.00	5.00	6.00	8.00	10.00	12.00	16.00	
4.2	60	280 - 340	0.100	0.130	0.180	0.210	0.250	0.350	0.460	0.580	0.700	
4.2	60	240 - 300	0.080	0.110	0.160	0.190	0.230	0.310	0.430	0.520	0.620	
4.2	60	260 - 320	0.100	0.130	0.180	0.210	0.250	0.350	0.450	0.560	0.650	
4.2	65	240 - 300	0.080	0.100	0.150	0.180	0.220	0.310	0.410	0.500	0.580	
4.2	60	280 - 340	0.100	0.130	0.170	0.200	0.240	0.340	0.430	0.520	0.620	
4.2	65	260 - 300	0.090	0.100	0.150	0.180	0.220	0.300	0.390	0.460	0.580	
4.2	65	240 - 280	0.080	0.100	0.140	0.170	0.210	0.290	0.380	0.440	0.560	
4.2	60	160 - 200	0.100	0.130	0.180	0.210	0.250	0.350	0.400	0.500	0.620	
4.2	60	180 - 220	0.100	0.110	0.160	0.200	0.230	0.330	0.380	0.470	0.590	
4.2	60	160 - 200	0.100	0.110	0.160	0.200	0.230	0.320	0.370	0.450	0.570	
4.2	70	250 - 300	0.100	0.130	0.180	0.210	0.250	0.350	0.460	0.580	0.700	
4.2	70	250 - 300	0.080	0.110	0.160	0.190	0.230	0.310	0.430	0.520	0.620	
4.2	70	200 - 250	0.100	0.130	0.180	0.210	0.250	0.350	0.450	0.560	0.650	
4.2	70	200 - 250	0.080	0.100	0.150	0.180	0.220	0.310	0.410	0.500	0.580	
4.2	70	220 - 270	0.100	0.130	0.180	0.210	0.250	0.350	0.450	0.560	0.650	
4.2	70	200 - 250	0.080	0.100	0.150	0.180	0.220	0.310	0.410	0.500	0.580	
4.2	70	180 - 250	0.071	0.103	0.135	0.170	0.210	0.280	0.350	0.420	0.560	
4.2	65	150 - 200	0.066	0.096	0.127	0.158	0.190	0.256	0.320	0.385	0.510	
4	55	110 - 150	0.062	0.083	0.106	0.142	0.172	0.220	0.280	0.330	0.420	
3	40	80 - 120	0.044	0.065	0.086	0.109	0.131	0.170	0.210	0.245	0.305	
2.2	35	60 - 85	0.027	0.046	0.066	0.084	0.100	0.130	0.150	0.180	0.210	
3.5	45	90 - 120	0.055	0.070	0.090	0.120	0.140	0.180	0.220	0.250	0.320	

Finishing (flat areas)

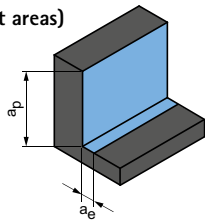

Plunge angle
0.5° - 1.0°

a_p [mm] in % of D	a_e [mm] in % of D	v_c [m/min]	f_z [mm]									
			Diameter of milling cutter [mm]									
			2.00	3.00	4.00	5.00	6.00	8.00	10.00	12.00	16.00	
0.8	8	160 - 185	0.040	0.048	0.058	0.072	0.105	0.144	0.182	0.210	0.290	
0.4	7.2	130 - 170	0.028	0.037	0.046	0.063	0.084	0.110	0.148	0.174	0.221	
0.2	6	110 - 130	0.018	0.028	0.038	0.055	0.070	0.082	0.118	0.140	0.162	
0.6	8	160 - 180	0.038	0.042	0.055	0.070	0.092	0.128	0.160	0.190	0.270	

For finishing operations on planar surfaces, depending on the material removal rate (a_e) and the selected machining strategy, residual material may remain on the part. For this reason, $a_e < d_{\min}$ should be selected for planar surfaces.

The specified machining values are guide values.

The optimum data for the respective machining task should be determined during the test or machining.

Cutting data recommendation for CPMill replaceable milling cutters

Feed and cutting speed

Correction factor:	
Length	f_z & v_c
A/B	1,0
C	0,9
D	0,7
E	0,6

Groove milling

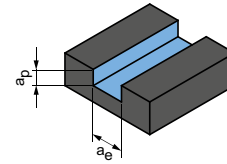

$$a_p = 0.05 \times D$$

$$a_e = 1 \times D$$

CPMill-Uni-FeedPlus | CPM171

MMG*	Workpiece material	Strength/hardness [N/mm ²] [HRC]	Cooling			v_c [m/min]	f_z [mm]						
			MQL/Air	Dry	Coolant		Diameter of milling cutter [mm]						
							8.00	10.00	12.00	16.00	20.00	25.00	
P	P1.1	Structural, free-cutting, case hardened and heat-treated steels, non-alloy	< 700	✓	✓	✓	160	0.179	0.214	0.246	0.301	0.344	0.383
	P1.2	Structural, free-cutting, case hardened and heat-treated steels, non-alloy	< 1200	✓	✓	✓	130	0.167	0.200	0.230	0.281	0.321	0.358
	P2.1	Nitrided, case hardened and heat-treated steels, alloy	< 900	✓	✓	✓	145	0.179	0.214	0.246	0.301	0.344	0.383
	P2.2	Nitrided, case hardened and heat-treated steels, alloy	< 1400	✓		✓	100	0.149	0.178	0.205	0.250	0.286	0.320
	P3.1	Tool, bearing, spring and high-speed steels**	< 800	✓	✓	✓	95	0.173	0.207	0.238	0.291	0.332	0.371
	P3.2	Tool, bearing, spring and high-speed steels**	< 1000	✓		✓	85	0.164	0.196	0.226	0.276	0.315	0.352
	P3.3	Tool, bearing, spring and high-speed steels**	< 1500	✓		✓	80	0.155	0.186	0.213	0.260	0.298	0.332
	P5	P5.1	Cast steel			✓	95	0.173	0.207	0.238	0.291	0.332	0.371
K	K1.1	Cast iron with lamellar graphite (grey cast iron), GJL	< 300	✓	✓	✓	175	0.298	0.357	0.410	0.501	0.573	0.639
	K2.1	Cast iron with spheroidal graphite, GJS	< 500	✓	✓	✓	160	0.253	0.303	0.349	0.426	0.487	0.543
	K2.2	Cast iron with spheroidal graphite, GJS	500-800	✓	✓	✓	130	0.209	0.250	0.287	0.351	0.401	0.447
	K2.3	Cast iron with spheroidal graphite, GJS	> 800	✓	✓	✓	70	0.119	0.143	0.164	0.200	0.229	0.256
	K3.1	Cast iron with spheroidal graphite, GJV; malleable cast iron, GJM	< 500	✓	✓	✓	115	0.209	0.250	0.287	0.351	0.401	0.447
	K3.2	Cast iron with spheroidal graphite, GJV; malleable cast iron, GJM	> 500	✓	✓	✓	110	0.179	0.214	0.246	0.301	0.344	0.383

* MAPAL machining groups

** If the alloy parts Cr, Mo, Ni, V, W in total > 8%, then select the next highest MAPAL machining group.

Roughing

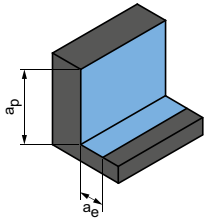

$$a_p = 00.5xD$$

$$a_e = 0.25xD$$

Finishing

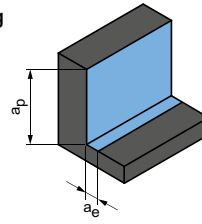

$$a_p = 00.5xD$$

$$a_e = 0.1xD$$

	v_c [m/min]	f_z [mm]						v_c [m/min]	f_z [mm]					
		Diameter of milling cutter [mm]							Diameter of milling cutter [mm]					
		8.00	10.00	12.00	16.00	20.00	25.00		8.00	10.00	12.00	16.00	20.00	25.00
	285	0.357	0.428	0.492	0.601	0.687	0.767	385	0.565	0.677	0.778	0.950	1.087	1.213
	235	0.334	0.400	0.459	0.561	0.641	0.716	315	0.528	0.632	0.726	0.887	1.014	1.132
	260	0.357	0.428	0.492	0.601	0.687	0.767	350	0.565	0.677	0.778	0.950	1.087	1.213
	180	0.298	0.357	0.410	0.501	0.573	0.639	245	0.471	0.564	0.648	0.792	0.906	1.011
	170	0.346	0.414	0.476	0.581	0.664	0.741	225	0.546	0.654	0.752	0.919	1.050	1.172
	155	0.328	0.392	0.451	0.551	0.630	0.703	210	0.518	0.621	0.713	0.871	0.996	1.112
	145	0.310	0.371	0.426	0.521	0.596	0.665	190	0.490	0.587	0.674	0.824	0.942	1.051
	175	0.346	0.414	0.476	0.581	0.664	0.741	235	0.546	0.654	0.752	0.919	1.050	1.172
	355	0.596	0.714	0.820	1.002	1.145	1.278	520	0.942	1.128	1.297	1.584	1.811	2.021
	325	0.506	0.607	0.697	0.852	0.974	1.087	475	0.801	0.959	1.102	1.346	1.539	1.718
	265	0.417	0.499	0.574	0.701	0.802	0.895	390	0.659	0.790	0.908	1.109	1.268	1.415
	145	0.238	0.285	0.328	0.401	0.458	0.511	215	0.377	0.451	0.519	0.634	0.724	0.808
	235	0.417	0.499	0.574	0.701	0.802	0.895	345	0.659	0.790	0.908	1.109	1.268	1.415
	220	0.357	0.428	0.492	0.601	0.687	0.767	325	0.565	0.677	0.778	0.950	1.087	1.213

The specified machining values are guide values.
The optimum data for the respective machining task should be determined during the test or machining.



PROFILE MILLING

Universal application

OptiMill-3D-BN	182
CPMill-Uni-Radius	184
CPMill-Uni-Torus	185

Hardened steel

OptiMill-3D-BN-Hardened	183
-------------------------------	-----

Non-ferrous metals

OptiMill-Diamond-Radius	186
OptiMill-Diamond-Torus	187

Plastics and composite materials

OptiMill-Composite-Speed-Radius	188
---------------------------------------	-----

Technical appendix

Cutting data recommendations	190
------------------------------------	-----



OptiMill®-3D-BN

Ball nose milling cutter, cylindrical design with working depth
MBN101

Design:

Diameter of milling cutter: 1.00 - 12.00 mm
Cutting material: HP801/HP820
Number of cutting edges: 2
Helix angle: 28°
Radial contour tolerance: ±0.005 if $d_1 \leq 6$ mm
±0.01 if $d_1 > 6$ mm

Application:

Suitable for machining workpiece materials up to 55 HRC.

Shank transition:

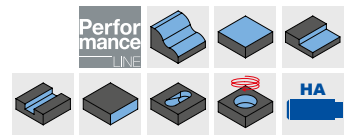
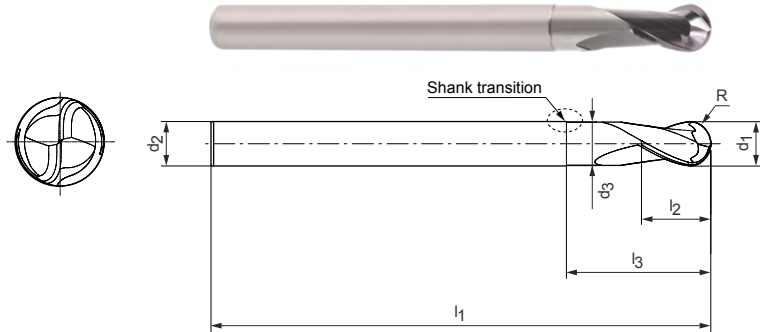
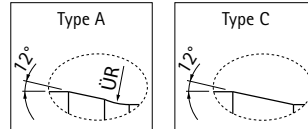

Preferred series in stock

Dimensions						Working depth at x° incline				Type	Specification	Order no.	
d ₁	R	l ₃	d ₂ h5	l ₁	l ₂	d ₃	0.5 °	1°	1.5 °				3°
1,00	0,5	3	4	50	1,2	0,94	3,47	3,57	3,66	4,01	A	MBN101-010-0050-0300X050-HP820	31153292
1,00	0,5	5	4	50	1,2	0,94	5,54	5,68	5,8	6,66	A	MBN101-010-0050-0500X050-HP820	31153294
2,00	1	8	4	50	2,3	1,94	9,09	9,45	9,74	10,49	A	MBN101-020-0100-0800X050-HP801	31153313
2,50	1,25	25	6	75	2,9	2,44	26,72	27,37	28,5	32,97	A	MBN101-025-0125-2500X075-HP801	31153328
3,00	1,5	10	6	60	3,5	2,94	11,17	11,56	11,88	12,98	A	MBN101-030-0150-1000X060-HP801	31153329
3,00	1,5	15	6	60	3,5	2,94	16,38	16,87	17,26	19,62	A	MBN101-030-0150-1500X060-HP801	31153330
3,00	1,5	20	6	60	3,5	2,94	21,56	22,13	22,76	26,25	A	MBN101-030-0150-2000X060-HP801	31153331
3,00	1,5	25	6	75	3,5	2,94	26,71	27,36	28,47	32,2	A	MBN101-030-0150-2500X075-HP801	31153332
4,00	2	10	6	60	4,6	3,94	11,14	11,52	11,84	12,82	A	MBN101-040-0200-1000X060-HP801	31153333
4,00	2	15	6	60	4,6	3,94	16,36	16,84	17,23	19,46	A	MBN101-040-0200-1500X060-HP801	31153334
4,00	2	20	6	60	4,6	3,94	21,54	22,1	22,69	24,85	A	MBN101-040-0200-2000X060-HP801	31153335
4,00	2	25	6	75	4,6	3,94	26,7	27,33	28,4	29,85	A	MBN101-040-0200-2500X075-HP801	31153336
4,00	2	30	6	75	4,6	3,94	31,84	32,66	34,1	34,85	A	MBN101-040-0200-3000X075-HP801	31153337
4,00	2	35	6	75	4,6	3,94	36,98	38,11	39,8	39,85	A	MBN101-040-0200-3500X075-HP801	31153338
5,00	2,5	15	6	60	5,8	4,9	15,78	16,38	17,03	17,59	C	MBN101-050-0250-1500X060-HP801	31153339
5,00	2,5	20	6	60	5,8	4,9	21	21,82	22,59	-	C	MBN101-050-0250-2000X060-HP801	31153340
5,00	2,5	25	6	60	5,8	4,9	26,21	27,27	27,59	-	C	MBN101-050-0250-2500X060-HP801	31153341
5,00	2,5	30	6	75	5,8	4,9	31,42	32,59	-	-	C	MBN101-050-0250-3000X075-HP801	31153342
6,00	3	15	6	60	6,9	5,9	-	-	-	-	-	MBN101-060-0300-1500X060-HP801	31153343
6,00	3	20	6	60	6,9	5,9	-	-	-	-	-	MBN101-060-0300-2000X060-HP801	31153344
6,00	3	25	6	60	6,9	5,9	-	-	-	-	-	MBN101-060-0300-2500X060-HP801	31153345
6,00	3	30	6	75	6,9	5,9	-	-	-	-	-	MBN101-060-0300-3000X075-HP801	31153346
6,00	3	35	6	75	6,9	5,9	-	-	-	-	-	MBN101-060-0300-3500X075-HP801	31153347
8,00	4	25	8	64	9,2	7,8	-	-	-	-	-	MBN101-080-0400-2500X064-HP801	31153348
8,00	4	50	8	100	9,2	7,8	-	-	-	-	-	MBN101-080-0400-5000X100-HP801	31153349
10,00	5	30	10	75	11,5	9,8	-	-	-	-	-	MBN101-100-0500-3000X075-HP801	31153350
10,00	5	50	10	100	11,5	9,8	-	-	-	-	-	MBN101-100-0500-5000X100-HP801	31153351
12,00	6	35	12	75	13,8	11,8	-	-	-	-	-	MBN101-120-0600-3500X075-HP801	31153352
12,00	6	60	12	100	13,8	11,8	-	-	-	-	-	MBN101-120-0600-6000X100-HP801	31153353

Dimensions in mm.
For cutting data recommendations, see end of chapter.
Special designs and other coatings available upon request.

OptiMill®-3D-BN-Hardened

Ball nose milling cutter, design with working depth
MBN107

Design:

Diameter of milling cutter: 3.00 - 12.00 mm
Cutting material: HP808/HP818
Number of cutting edges: 2
Helix angle: 30°
Radial contour tolerance: ±0.005 if $d_1 \leq 6$ mm
±0.01 if $d_1 > 6$ mm

Application:

Suitable for machining workpiece materials up to 68 HRC.

Shank transition:

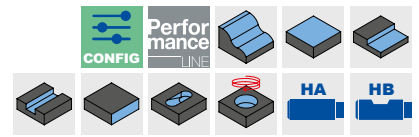
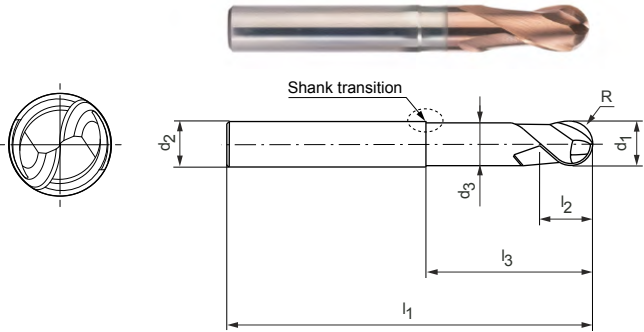
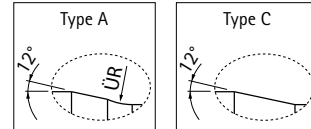

Preferred series in stock

Dimensions						Working depth at x° incline				Type	Shank form HA		Order no.
d ₁	R	l ₃	d ₂ h5	l ₁	l ₂	d ₃	0.5 °	1°	1.5 °		3°	Specification	
3,00	1,5	10	6	60	3,5	2,94	11,17	11,56	11,88	12,98	A	MBN107-030-0150-1000X060-HP808	31153744
3,00	1,5	15	6	60	3,5	2,94	16,38	16,87	17,26	19,62	A	MBN107-030-0150-1500X060-HP808	31153745
3,00	1,5	20	6	60	3,5	2,94	21,56	22,13	22,76	26,25	A	MBN107-030-0150-2000X060-HP808	31153746
3,00	1,5	25	6	75	3,5	2,94	26,71	27,36	28,47	32,2	A	MBN107-030-0150-2500X075-HP808	31153748
4,00	2	10	6	60	4,6	3,94	11,14	11,52	11,84	12,82	A	MBN107-040-0200-1000X060-HP808	31153749
4,00	2	15	6	60	4,6	3,94	16,36	16,84	17,23	19,46	A	MBN107-040-0200-1500X060-HP808	31153750
4,00	2	20	6	60	4,6	3,94	21,54	22,1	22,69	24,85	A	MBN107-040-0200-2000X060-HP808	31153751
4,00	2	25	6	75	4,6	3,94	26,7	27,33	28,4	29,85	A	MBN107-040-0200-2500X075-HP808	31153752
4,00	2	30	6	75	4,6	3,94	31,84	32,66	34,1	34,85	A	MBN107-040-0200-3000X075-HP808	31153753
4,00	2	35	6	75	4,6	3,94	36,98	38,11	39,8	39,85	A	MBN107-040-0200-3500X075-HP808	31153754
5,00	2,5	15	6	60	5,8	4,9	15,78	16,38	17,03	17,59	C	MBN107-050-0250-1500X060-HP808	31153755
5,00	2,5	20	6	60	5,8	4,9	21	21,82	22,59	-	C	MBN107-050-0250-2000X060-HP808	31153756
5,00	2,5	25	6	60	5,8	4,9	26,21	27,27	27,59	-	C	MBN107-050-0250-2500X060-HP808	31153757
5,00	2,5	30	6	75	5,8	4,9	31,42	32,59	-	-	C	MBN107-050-0250-3000X075-HP808	31153758
6,00	3	15	6	60	6,9	5,9	-	-	-	-	-	MBN107-060-0300-1500X060-HP808	31153759
6,00	3	20	6	60	6,9	5,9	-	-	-	-	-	MBN107-060-0300-2000X060-HP808	31153760
6,00	3	25	6	60	6,9	5,9	-	-	-	-	-	MBN107-060-0300-2500X060-HP808	31153761
6,00	3	30	6	75	6,9	5,9	-	-	-	-	-	MBN107-060-0300-3000X075-HP808	31153762
6,00	3	35	6	75	6,9	5,9	-	-	-	-	-	MBN107-060-0300-3500X075-HP808	31153763
8,00	4	25	8	64	9,2	7,8	-	-	-	-	-	MBN107-080-0400-2500X064-HP808	31153764
8,00	4	50	8	100	9,2	7,8	-	-	-	-	-	MBN107-080-0400-5000X100-HP808	31153765
10,00	5	30	10	75	11,5	9,8	-	-	-	-	-	MBN107-100-0500-3000X075-HP808	31153766
10,00	5	50	10	100	11,5	9,8	-	-	-	-	-	MBN107-100-0500-5000X100-HP808	31153767
12,00	6	35	12	75	13,8	11,8	-	-	-	-	-	MBN107-120-0600-3500X075-HP808	31153768
12,00	6	60	12	100	13,8	11,8	-	-	-	-	-	MBN107-120-0600-6000X100-HP808	31153769

Configurable features

Shank form:
Shank form: HB

Dimensions in mm.

For cutting data recommendations, see end of chapter.

Special designs and other coatings available upon request.

CPMill®-Uni-Radius

Design with CFS connection
CPM150

Design:

Diameter of milling cutter: 8.00 – 25.00 mm
Cutting material: HP383
Number of cutting edges: 4
Helix angle: 30°

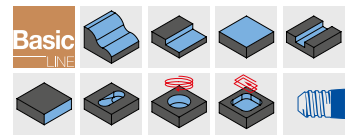
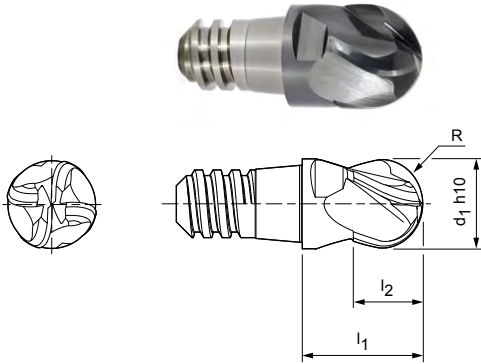

Preferred series in stock

Dimensions					z	ap max.	SW	Specification	Order no.
d1 h10	CFS size	l1	l2	R					
10,00	8	13	7,5	5	4	5,6	SW 8	CPM150-1000Z04-R0500-08-HP383	30371416
12,00	10	16	9	6	4	6,8	SW 10	CPM150-1200Z04-R0600-10-HP383	30371417
16,00	12	20	12	8	4	9	SW 13	CPM150-1600Z04-R0800-12-HP383	30371418
20,00	16	25	15	10	4	11,3	SW 16	CPM150-2000Z04-R1000-16-HP383	30371420

Available on request

8,00	6	11	6	4	4	4,5	SW 6	CPM150-0800Z04-R0400-06-HP383	30371595
25,00	20	32	19	12,5	4	14	SW 21	CPM150-2500Z04-R1250-20-HP383	30371421

Accessories

	CFS replaceable head holders CFS101 CFS201	Page 218
--	-------------------------------------------------	----------

Dimensions in mm.

For cutting data recommendations, see end of chapter.

Special designs and other coatings available upon request.

CPMill®-Uni-Torus

Design with CFS connection
CPM160

Design:

Diameter of milling cutter: 8.00 – 25.00 mm
Cutting material: HP383
Number of cutting edges: 4
Helix angle: 30°

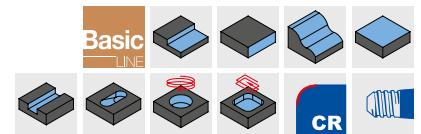
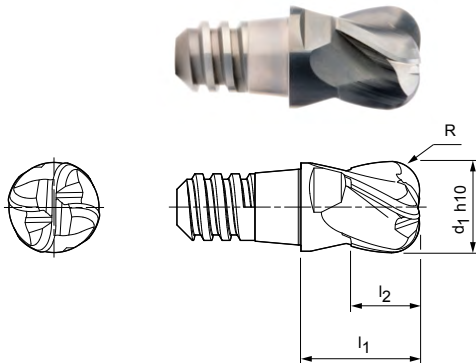

Preferred series in stock

Dimensions					z	a _p max.	SW	Specification	Order no.
d ₁ 10	CFS size	l ₁	l ₂	R					
8,00	6	11	6	1	4	4,5	SW 6	CPM160-0800Z04-R0100-06-HP383	30371402
8,00	6	11	6	2	4	4,5	SW 6	CPM160-0800Z04-R0200-06-HP383	30371403
10,00	8	13	7,5	1,5	4	5,6	SW 8	CPM160-1000Z04-R0150-08-HP383	30371404
10,00	8	13	7,5	3	4	5,6	SW 8	CPM160-1000Z04-R0300-08-HP383	30371405
12,00	10	16	9	1,5	4	6,8	SW 10	CPM160-1200Z04-R0150-10-HP383	30371406
12,00	10	16	9	4	4	6,8	SW 10	CPM160-1200Z04-R0400-10-HP383	30371407
16,00	12	20	12	2	4	9	SW 13	CPM160-1600Z04-R0200-12-HP383	30371408
16,00	12	20	12	5	4	9	SW 13	CPM160-1600Z04-R0500-12-HP383	30371409
20,00	16	25	15	2	4	11,3	SW 16	CPM160-2000Z04-R0200-16-HP383	30371412
20,00	16	25	15	6	4	11,3	SW 16	CPM160-2000Z04-R0600-16-HP383	30371413
25,00	20	32	19	6	4	14	SW 21	CPM160-2500Z04-R0600-20-HP383	30371415

Available on request

25,00	20	32	19	3	4	14	SW21	CPM160-2500Z04-R0300-20-HP383	30371414
-------	----	----	----	---	---	----	------	-------------------------------	----------

Accessories

	CFS replaceable head holders CFS101 CFS201	Page 218
-------------------------------------------------------------------------------------	-------------------------------------------------	----------

Dimensions in mm.

For cutting data recommendations, see end of chapter.

Special designs and other coatings available upon request.

OptiMill®-Diamond-Radius

Ball nose milling cutter, overlong design with neck, includes internal cooling
SHM521

Design:

Diameter of milling cutter: 3.00 – 16.00 mm
Cutting material: PU611
Number of cutting edges: 2
Axis angle: 0°
Special features: PCD cutting edges for a long tool life

Application:

Ideal for contour and form milling aluminium parts.

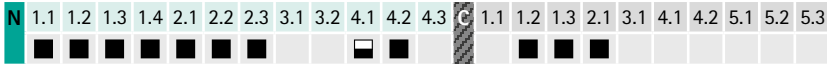
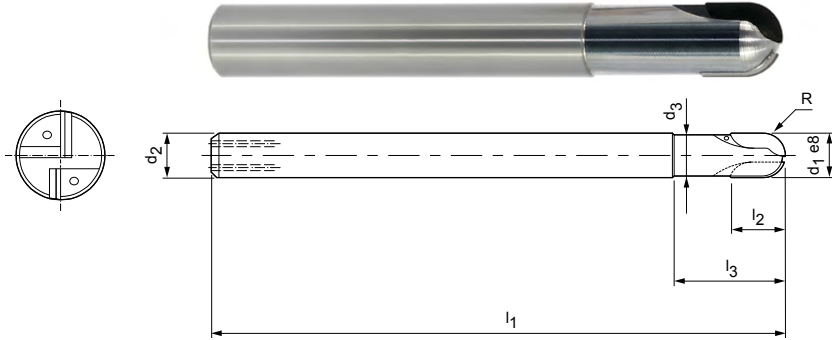

Preferred series in stock

Dimensions							z	Specification	Order no.
d ₁ h10	d ₂ h6	d ₃	l ₁	l ₂	l ₃	R			
3,00	6	2,8	60	2,5	9	1,5	2	SHM521-0300AZ02R-R0150HA-PU611	30340718
4,00	6	3,8	60	2,5	15	2	2	SHM521-0400AZ02R-R0200HA-PU611	30334958
5,00	6	4,6	60	3	15	2,5	2	SHM521-0500AZ02R-R0250HA-PU611	30340720
6,00	6	5,5	80	6	15	3	2	SHM521-0600BZ02R-R0300HA-PU611	30334960
8,00	8	6,9	80	10	20	4	2	SHM521-0800BZ02R-R0400HA-PU611	30696715
10,00	10	8,9	80	10	26	5	2	SHM521-1000BZ02R-R0500HA-PU611	30696716
12,00	12	11,2	100	10	35	6	2	SHM521-1200BZ02R-R0600HA-PU611	30324570
16,00	16	15	125	10	35	8	2	SHM521-1600BZ02R-R0800HA-PU611	30324494

Dimensions in mm.

For cutting data recommendations, see end of chapter.

Special designs and CVD-tipped tools available upon request.

OptiMill®-Diamond-Torus

Corner radius milling cutter, long design with neck, includes internal cooling
SHM551

Design:

Diameter of milling cutter: 3.00 – 12.00 mm
Cutting material: PU611
Number of cutting edges: 2
Axis angle: 0°
Special features: PCD cutting edges for a long tool life

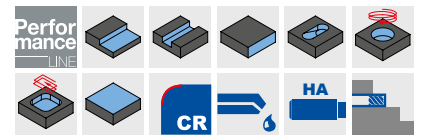
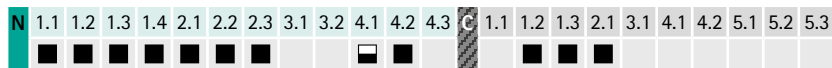
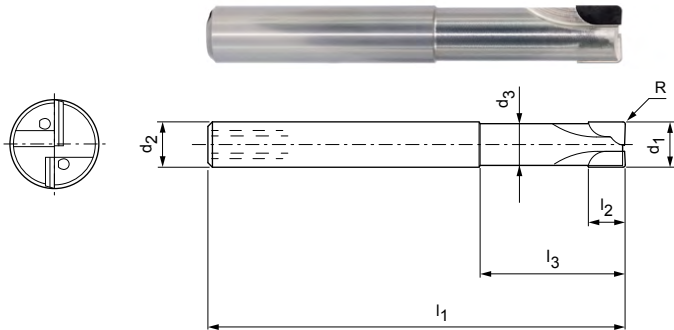

Preferred series in stock

Dimensions							z	Specification	Order no.
d ₁ e8	d ₂ h6	d ₃	l ₁	l ₂	l ₃	R			
3,00	6	2,8	50	2,5	14	0,3	2	SHM551-0300AZ02R-R0030HA-PU611	30334961
4,00	6	3,8	50	2,5	14	0,5	2	SHM551-0400AZ02R-R0050HA-PU611	30334966
5,00	6	4,6	54	3	18	0,5	2	SHM551-0500AZ02R-R0050HA-PU611	30334969
6,00	6	5,5	57	6	21	0,5	2	SHM551-0600BZ02R-R0050HA-PU611	30334973
6,00	6	5,5	57	6	21	1	2	SHM551-0600BZ02R-R0100HA-PU611	30334974
8,00	8	7,4	63	7	27	0,5	2	SHM551-0800BZ02R-R0050HA-PU611	30334976
10,00	10	9,2	72	8	32	0,5	2	SHM551-1000BZ02R-R0050HA-PU611	30334980
10,00	10	9,2	72	8	32	1	2	SHM551-1000BZ02R-R0100HA-PU611	30334981

Available on request

3,00	6	2,8	50	2,5	14	0,5	2	SHM551-0300AZ02R-R0050HA-PU611	30334962
3,00	6	2,8	50	2,5	14	1	2	SHM551-0300AZ02R-R0100HA-PU611	30334963
4,00	6	3,8	50	2,5	14	0,3	2	SHM551-0400AZ02R-R0030HA-PU611	30334964
4,00	6	3,8	50	2,5	14	1	2	SHM551-0400AZ02R-R0100HA-PU611	30334967
5,00	6	4,6	54	3	18	1	2	SHM551-0500AZ02R-R0100HA-PU611	30334971
6,00	6	5,5	57	6	21	1,5	2	SHM551-0600BZ02R-R0150HA-PU611	30334975
8,00	8	7,4	63	7	27	1	2	SHM551-0800BZ02R-R0100HA-PU611	30334977
8,00	8	7,4	63	7	27	1,5	2	SHM551-0800BZ02R-R0150HA-PU611	30334978
8,00	8	7,4	63	7	27	2	2	SHM551-0800BZ02R-R0200HA-PU611	30334979
10,00	10	9,2	72	8	32	1,5	2	SHM551-1000BZ02R-R0150HA-PU611	30334982
10,00	10	9,2	72	8	32	2	2	SHM551-1000BZ02R-R0200HA-PU611	30334983
12,00	12	11,2	83	9	38	0,5	2	SHM551-1200BZ02R-R0050HA-PU611	30334984
12,00	12	11,2	83	9	38	1	2	SHM551-1200BZ02R-R0100HA-PU611	30334985
12,00	12	11,2	83	9	38	1,5	2	SHM551-1200BZ02R-R0150HA-PU611	30334986
12,00	12	11,2	83	9	38	2	2	SHM551-1200BZ02R-R0200HA-PU611	30334987

Dimensions in mm.

For cutting data recommendations, see end of chapter.

Special designs available upon request.

OptiMill®-Composite-Speed-Radius

Ball nose milling cutter, design with pulling cut, with full radius
SCM870

Design:

Diameter of milling cutter: 4.00 - 20.00 mm
Cutting material: HC611/HC619
Number of cutting edges: 8
Helix angle: 8°
Special features: Diamond coating for long tool life

Application:

Pulling cutting edge for better removal of the chips/dust (e.g. on milling pockets and slots). Particularly suitable for difficult to machine surface layers (e.g. UD or copper mesh) to prevent delamination on the lower edge of the part.

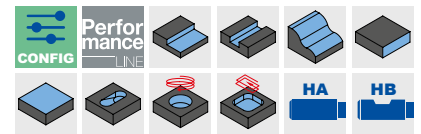
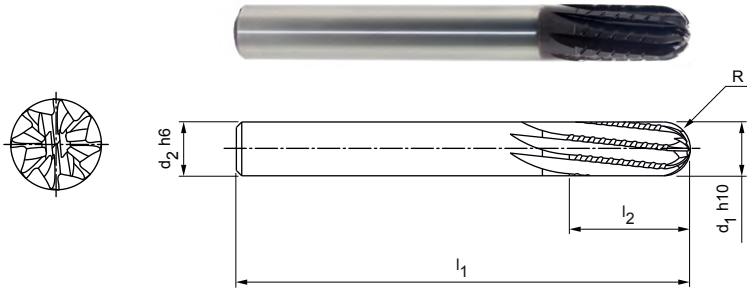

Preferred series in stock

Dimensions					z	Specification	Order no.
d ₁ h10	d ₂ h6	l ₁	l ₂	R			
4,00	6	60	16	2	8	SCM870-0400Z08R-R0200HA-HC619	30869182
6,00	6	75	28	3	8	SCM870-0600Z08R-R0300HA-HC619	30869186
8,00	8	75	32	4	8	SCM870-0800Z08R-R0400HA-HC619	30869188
10,00	10	72	32	5	8	SCM870-1000Z08R-R0500HA-HC619	30869189

Available on request

12,00	12	83	32	6	8	SCM870-1200Z08R-R0600HA-HC611	30869190
16,00	16	92	36	8	8	SCM870-1600Z08R-R0800HA-HC611	30869191
20,00	20	104	45	10	8	SCM870-2000Z08R-R1000HA-HC611	30869192

Configurable features



Shank form:
Shank form: HB



Specification up to ø 10 mm:
SCM870-0400Z08R-R0200[shank form]-HC619

Specification from ø 12 mm:
SCM870-1200Z08R-R0600[shank form]-HC611

Example:

SCM870-0400Z08R-R0200**HB**-HC619

Shank form HB

Dimensions in mm.

For cutting data recommendations, see end of chapter.

Special designs and other coatings available upon request.



Cutting data recommendations for Ball nose milling cutter

Feed and cutting speed

OptiMill-3D-BN | MBN101

MMG*	Workpiece material	Strength/hardness [N/mm ²] [HRC]	Cooling			
			MQL/Air	Dry	Coolant	
P	P1.1	Structural, free-cutting, case hardened and heat-treated steels, non-alloy	< 700	✓	✓	✓
	P1.2	Structural, free-cutting, case hardened and heat-treated steels, non-alloy	< 1200	✓	✓	✓
	P2.1	Nitrided, case hardened and heat-treated steels, alloy	< 900	✓	✓	✓
	P2.2	Nitrided, case hardened and heat-treated steels, alloy	< 1400	✓	✓	✓
	P3.1	Tool, bearing, spring and high-speed steels**	< 800	✓	✓	✓
	P3.2	Tool, bearing, spring and high-speed steels**	< 1000	✓	✓	✓
	P3.3	Tool, bearing, spring and high-speed steels**	< 1500	✓	✓	✓
	P4.1	Stainless steels, ferritic and martensitic		✓		✓
	P5.1	Cast steel		✓		✓
	P6.1	Stainless cast steel, ferritic and martensitic		✓		✓
M	M1.1	Stainless steels, austenitic	< 700			✓
	M1.2	Stainless steels, ferritic/austenitic (duplex)	< 1000			✓
	M2.1	Stainless/heat-resistant cast steel, austenitic	< 700			✓
	M3.1	Stainless cast steel, ferritic/austenitic (duplex)	< 1000			✓
K	K1.1	Cast iron with lamellar graphite (grey cast iron), GJL	< 300	✓	✓	✓
	K2.1	Cast iron with spheroidal graphite, GJS	< 500	✓	✓	✓
	K2.2	Cast iron with spheroidal graphite, GJS	≤ 800	✓	✓	✓
	K2.3	Cast iron with spheroidal graphite, GJS	> 800	✓	✓	✓
	K3.1	Cast iron with spheroidal graphite, GJV; malleable cast iron, GJM	< 500	✓	✓	✓
	K3.2	Cast iron with spheroidal graphite, GJV; malleable cast iron, GJM	> 500	✓	✓	✓
H	H1.1	Hardened steel / cast steel	< 44	✓	✓	
	H1.2	Hardened steel / cast steel	< 55	✓	✓	
	H2.1	Hardened steel / cast steel	< 60	✓		

Working depth correction factor - k_{AT}

AT	k_{AT}		
	a_p	n	v_f
≤ 3xD	1,00	1,00	1,00
≤ 5xD	0,80	0,90	0,90
≤ 6xD	0,70	0,85	0,85
≤ 8xD	0,60	0,75	0,75
≤ 10xD	0,50	0,70	0,70
≤ 12xD	0,45***	0,65	0,65
≤ 15xD	0,40***	0,60	0,60
≤ 20xD	0,35***	0,60	0,60
≤ 25xD	0,35***	0,50	0,50
≤ 30xD	0,30***	0,50	0,50
≤ 35xD	0,30***	0,50	0,50

Cone angle correction factor - k_{KW}

φ [°]	k_{KW}		
	a_p	n	v_f
0	1,00	1,00	1,00
0,5	1,01	1,01	1,01
1	1,02	1,02	1,02
1,5	1,03	1,03	1,03
3	1,06	1,06	1,06

* MAPAL machining groups

** If the alloy parts Cr, Mo, Ni, V, W in total > 8%, then select the next highest MAPAL machining group.

*** Consultation with a MAPAL application engineer.

Roughing

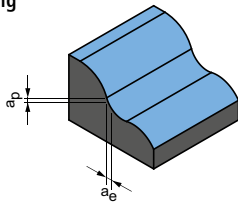

Plunge angle
1.0 ° - 3.0 °

Next page:
Finishing

a _p [mm] in % of D	a _e [mm] in % of D	V _c [m/min]	f _z [mm]																			
			Diameter of milling cutter [mm]																			
			0.10	0.20	0.30	0.40	0.50	0.60	0.80	1.00	1.50	1.80	2.00	2.50	3.00	4.00	5.00	6.00	8.00	10.00	12.00	16.00
5	< 25	250-300	0.003	0.004	0.006	0.008	0.010	0.012	0.016	0.020	0.028	0.035	0.040	0.050	0.061	0.084	0.107	0.125	0.165	0.200	0.235	0.300
4.5	< 25	240-280	0.003	0.004	0.005	0.007	0.009	0.011	0.014	0.018	0.025	0.031	0.035	0.044	0.054	0.074	0.094	0.110	0.145	0.176	0.207	0.264
5	< 25	250-300	0.003	0.004	0.006	0.008	0.010	0.012	0.016	0.020	0.028	0.035	0.040	0.050	0.061	0.084	0.107	0.125	0.165	0.200	0.235	0.300
4.5	< 25	240-280	0.003	0.004	0.005	0.007	0.009	0.011	0.014	0.018	0.025	0.031	0.035	0.044	0.054	0.074	0.094	0.110	0.145	0.176	0.207	0.264
5	< 25	250-300	0.003	0.004	0.006	0.008	0.010	0.011	0.015	0.019	0.027	0.033	0.038	0.048	0.058	0.080	0.102	0.119	0.157	0.190	0.223	0.285
4.5	< 20	240-280	0.003	0.004	0.005	0.007	0.009	0.011	0.014	0.018	0.025	0.031	0.035	0.044	0.054	0.074	0.094	0.110	0.145	0.176	0.207	0.264
4	< 20	220-260	0.002	0.003	0.004	0.006	0.007	0.009	0.012	0.015	0.020	0.026	0.029	0.037	0.045	0.061	0.078	0.091	0.120	0.146	0.172	0.219
5	< 25	240-280	0.003	0.004	0.006	0.008	0.010	0.012	0.016	0.020	0.028	0.035	0.040	0.050	0.061	0.084	0.107	0.125	0.165	0.200	0.235	0.300
5	< 25	240-280	0.003	0.004	0.005	0.007	0.009	0.011	0.014	0.018	0.025	0.031	0.035	0.044	0.054	0.074	0.094	0.110	0.145	0.176	0.207	0.264
4.5	< 25	200-250	0.002	0.003	0.004	0.006	0.007	0.009	0.012	0.015	0.020	0.026	0.029	0.037	0.045	0.061	0.078	0.091	0.120	0.146	0.172	0.219
5	< 25	85-110	0.003	0.004	0.005	0.007	0.009	0.011	0.014	0.018	0.025	0.031	0.035	0.044	0.054	0.074	0.094	0.110	0.145	0.176	0.207	0.264
5	< 25	60-85	0.002	0.003	0.004	0.006	0.007	0.009	0.012	0.015	0.020	0.026	0.029	0.037	0.045	0.061	0.078	0.091	0.120	0.146	0.172	0.219
5	< 25	85-110	0.003	0.004	0.005	0.007	0.009	0.011	0.014	0.018	0.025	0.031	0.035	0.044	0.054	0.074	0.094	0.110	0.145	0.176	0.207	0.264
5	< 25	60-85	0.002	0.003	0.004	0.006	0.007	0.009	0.012	0.015	0.020	0.026	0.029	0.037	0.045	0.061	0.078	0.091	0.120	0.146	0.172	0.219
6	< 30	250-300	0.004	0.005	0.007	0.010	0.012	0.014	0.019	0.024	0.034	0.042	0.048	0.060	0.073	0.101	0.128	0.150	0.198	0.240	0.282	0.360
6	< 30	250-300	0.003	0.004	0.006	0.008	0.010	0.012	0.016	0.020	0.028	0.035	0.040	0.050	0.061	0.084	0.107	0.125	0.165	0.200	0.235	0.300
6	< 30	240-280	0.003	0.004	0.006	0.008	0.010	0.012	0.016	0.020	0.028	0.035	0.040	0.050	0.061	0.084	0.107	0.125	0.165	0.200	0.235	0.300
6	< 30	240-280	0.003	0.004	0.005	0.007	0.009	0.011	0.014	0.018	0.025	0.031	0.035	0.044	0.054	0.074	0.094	0.110	0.145	0.176	0.207	0.264
6	< 30	250-300	0.002	0.003	0.004	0.006	0.007	0.009	0.012	0.015	0.020	0.026	0.029	0.037	0.045	0.061	0.078	0.091	0.120	0.146	0.172	0.219
6	< 30	240-280	0.002	0.002	0.004	0.005	0.006	0.007	0.010	0.012	0.017	0.022	0.025	0.031	0.038	0.052	0.066	0.078	0.102	0.124	0.146	0.186
4	< 18	220-280	0.002	0.003	0.004	0.006	0.007	0.009	0.012	0.015	0.020	0.026	0.029	0.037	0.045	0.061	0.078	0.091	0.120	0.146	0.172	0.219
3	< 12	160-220	0.002	0.002	0.004	0.005	0.006	0.007	0.010	0.012	0.017	0.021	0.024	0.030	0.037	0.050	0.064	0.075	0.099	0.120	0.141	0.180
1.5	< 3	100-160	0.001	0.002	0.002	0.003	0.004	0.005	0.006	0.008	0.011	0.014	0.016	0.020	0.024	0.034	0.043	0.050	0.066	0.080	0.094	0.120

The specified machining values are guide values.
The optimum data for the respective machining task should be determined during the test or machining.

Cutting data recommendations for Ball nose milling cutter

Feed and cutting speed

OptiMill-3D-BN | MBN101

MMG*	Workpiece material	Strength/hardness [N/mm ²] [HRC]	Cooling			
			MQL/Air	Dry	Coolant	
P	P1.1	Structural, free-cutting, case hardened and heat-treated steels, non-alloy	< 700	✓	✓	✓
	P1.2	Structural, free-cutting, case hardened and heat-treated steels, non-alloy	< 1200	✓	✓	✓
	P2.1	Nitrided, case hardened and heat-treated steels, alloy	< 900	✓	✓	✓
	P2.2	Nitrided, case hardened and heat-treated steels, alloy	< 1400	✓	✓	✓
	P3.1	Tool, bearing, spring and high-speed steels**	< 800	✓	✓	✓
	P3.2	Tool, bearing, spring and high-speed steels**	< 1000	✓	✓	✓
	P3.3	Tool, bearing, spring and high-speed steels**	< 1500	✓	✓	✓
	P4.1	Stainless steels, ferritic and martensitic		✓		✓
	P5.1	Cast steel		✓		✓
	P6.1	Stainless cast steel, ferritic and martensitic		✓		✓
M	M1.1	Stainless steels, austenitic	< 700			✓
	M1.2	Stainless steels, ferritic/austenitic (duplex)	< 1000			✓
	M2.1	Stainless/heat-resistant cast steel, austenitic	< 700			✓
	M3.1	Stainless cast steel, ferritic/austenitic (duplex)	< 1000			✓
K	K1.1	Cast iron with lamellar graphite (grey cast iron), GJL	< 300	✓	✓	✓
	K2.1	Cast iron with spheroidal graphite, GJS	< 500	✓	✓	✓
	K2.2	Cast iron with spheroidal graphite, GJS	≤ 800	✓	✓	✓
	K2.3	Cast iron with spheroidal graphite, GJS	> 800	✓	✓	✓
	K3.1	Cast iron with spheroidal graphite, GJV; malleable cast iron, GJM	< 500	✓	✓	✓
	K3.2	Cast iron with spheroidal graphite, GJV; malleable cast iron, GJM	> 500	✓	✓	✓
H	H1.1	Hardened steel / cast steel	< 44	✓	✓	
	H1.2	Hardened steel / cast steel	< 55	✓	✓	
	H2.1	Hardened steel / cast steel	< 60	✓		

Working depth correction factor - k_{AT}

AT	k_{AT}		
	a_p	n	v_f
≤ 3xD	1,00	1,00	1,00
≤ 5xD	0,80	0,90	0,90
≤ 6xD	0,70	0,85	0,85
≤ 8xD	0,60	0,75	0,75
≤ 10xD	0,50	0,70	0,70
≤ 12xD	0,45***	0,65	0,65
≤ 15xD	0,40***	0,60	0,60
≤ 20xD	0,35***	0,60	0,60
≤ 25xD	0,35***	0,50	0,50
≤ 30xD	0,30***	0,50	0,50
≤ 35xD	0,30***	0,50	0,50

Cone angle correction factor - k_{KW}

φ [°]	k_{KW}		
	a_p	n	v_f
0	1,00	1,00	1,00
0,5	1,01	1,01	1,01
1	1,02	1,02	1,02
1,5	1,03	1,03	1,03
3	1,06	1,06	1,06

* MAPAL machining groups

** If the alloy parts Cr, Mo, Ni, V, W in total > 8%, then select the next highest MAPAL machining group.

*** Consultation with a MAPAL application engineer.

Finishing

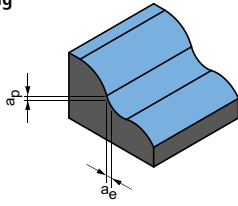

Plunge angle
0.5° - 1.0°

a_p [mm] in % of D	a_e [mm] in % of D	v_c [m/min]	f_z [mm]																			
			Diameter of milling cutter [mm]																			
			0.10	0.20	0.30	0.40	0.50	0.60	0.80	1.00	1.50	1.80	2.00	2.50	3.00	4.00	5.00	6.00	8.00	10.00	12.00	16.00
1.5	2.5	280-340	0.003	0.004	0.006	0.008	0.010	0.011	0.015	0.019	0.027	0.033	0.038	0.048	0.058	0.080	0.102	0.119	0.157	0.190	0.223	0.285
1.4	2.4	280-320	0.003	0.003	0.005	0.007	0.008	0.010	0.013	0.017	0.023	0.029	0.033	0.042	0.051	0.070	0.089	0.105	0.138	0.167	0.196	0.251
1.4	2.4	270-320	0.003	0.004	0.006	0.008	0.010	0.011	0.015	0.019	0.027	0.033	0.038	0.048	0.058	0.080	0.102	0.119	0.157	0.190	0.223	0.285
1.3	2.3	260-300	0.003	0.003	0.005	0.007	0.008	0.010	0.013	0.017	0.023	0.029	0.033	0.042	0.051	0.070	0.089	0.105	0.138	0.167	0.196	0.251
1.3	2.3	280-320	0.003	0.004	0.005	0.007	0.009	0.011	0.014	0.018	0.025	0.032	0.036	0.045	0.055	0.076	0.097	0.113	0.149	0.181	0.212	0.271
1.2	2.2	260-300	0.002	0.003	0.005	0.006	0.008	0.010	0.013	0.016	0.022	0.028	0.032	0.040	0.048	0.067	0.085	0.099	0.131	0.159	0.187	0.238
1	2	240-280	0.002	0.003	0.004	0.006	0.007	0.008	0.011	0.014	0.019	0.024	0.028	0.035	0.042	0.058	0.074	0.087	0.114	0.139	0.163	0.208
1.3	2.3	260-300	0.003	0.004	0.006	0.008	0.010	0.011	0.015	0.019	0.027	0.033	0.038	0.048	0.058	0.080	0.102	0.119	0.157	0.190	0.223	0.285
1.3	2.3	260-300	0.003	0.003	0.005	0.007	0.008	0.010	0.013	0.017	0.023	0.029	0.033	0.042	0.051	0.070	0.089	0.105	0.138	0.167	0.196	0.251
1.2	2.2	220-270	0.002	0.003	0.004	0.006	0.007	0.008	0.011	0.014	0.019	0.024	0.028	0.035	0.042	0.058	0.074	0.087	0.114	0.139	0.163	0.208
1.3	2.3	90-120	0.003	0.003	0.005	0.007	0.008	0.010	0.013	0.017	0.023	0.029	0.033	0.042	0.051	0.070	0.089	0.105	0.138	0.167	0.196	0.251
1.2	2.2	70-90	0.002	0.003	0.004	0.006	0.007	0.008	0.011	0.014	0.019	0.024	0.028	0.035	0.042	0.058	0.074	0.087	0.114	0.139	0.163	0.208
1.3	2.3	90-120	0.003	0.003	0.005	0.007	0.008	0.010	0.013	0.017	0.023	0.029	0.033	0.042	0.051	0.070	0.089	0.105	0.138	0.167	0.196	0.251
1.2	2.2	70-90	0.002	0.003	0.004	0.006	0.007	0.008	0.011	0.014	0.019	0.024	0.028	0.035	0.042	0.058	0.074	0.087	0.114	0.139	0.163	0.208
1.5	2.5	280-340	0.003	0.004	0.006	0.008	0.010	0.011	0.015	0.019	0.027	0.033	0.038	0.048	0.058	0.080	0.102	0.119	0.157	0.190	0.223	0.285
1.4	2.4	280-320	0.003	0.003	0.005	0.007	0.008	0.010	0.013	0.017	0.023	0.029	0.033	0.042	0.051	0.070	0.089	0.105	0.138	0.167	0.196	0.251
1.3	2.3	270-320	0.003	0.003	0.005	0.007	0.008	0.010	0.013	0.017	0.023	0.029	0.033	0.042	0.051	0.070	0.089	0.105	0.138	0.167	0.196	0.251
1.2	2.2	260-300	0.003	0.003	0.005	0.007	0.008	0.010	0.013	0.017	0.023	0.029	0.033	0.042	0.051	0.070	0.089	0.105	0.138	0.167	0.196	0.251
1.4	2.4	280-320	0.002	0.003	0.004	0.006	0.007	0.008	0.011	0.014	0.019	0.024	0.028	0.035	0.042	0.058	0.074	0.087	0.114	0.139	0.163	0.208
1.3	2.3	260-300	0.002	0.002	0.004	0.005	0.006	0.007	0.009	0.012	0.017	0.021	0.024	0.029	0.036	0.050	0.063	0.074	0.097	0.118	0.139	0.177
1.2	2.2	240-280	0.002	0.003	0.004	0.006	0.007	0.009	0.012	0.014	0.020	0.025	0.029	0.036	0.044	0.061	0.077	0.090	0.119	0.144	0.170	0.217
1	2	160-240	0.002	0.003	0.004	0.005	0.007	0.008	0.011	0.014	0.019	0.024	0.027	0.034	0.042	0.058	0.073	0.086	0.113	0.137	0.161	0.206
0.8	1.8	120-160	0.001	0.002	0.003	0.004	0.005	0.006	0.008	0.010	0.013	0.017	0.019	0.024	0.029	0.040	0.051	0.060	0.079	0.096	0.113	0.144

The specified machining values are guide values.

The optimum data for the respective machining task should be determined during the test or machining.

Cutting data recommendations for Ball nose milling cutter

Feed and cutting speed

OptiMill-3D-BN-Hardened | MBN107

MMG*	Workpiece material		Strength/hardness [N/mm ²] [HRC]	Cooling				
				ML/Air	Dry	Coolant		
P	P1	P1.1	Structural, free-cutting, case hardened and heat-treated steels, non-alloy	< 700	✓	✓	✓	
		P1.2	Structural, free-cutting, case hardened and heat-treated steels, non-alloy	< 1200	✓	✓	✓	
	P2	P2.1	Nitrided, case hardened and heat-treated steels, alloy	< 900	✓	✓	✓	
		P2.2	Nitrided, case hardened and heat-treated steels, alloy	< 1400	✓	✓	✓	
	P3	P3.1	Tool, bearing, spring and high-speed steels**	< 800	✓	✓	✓	
		P3.2	Tool, bearing, spring and high-speed steels**	< 1000	✓	✓	✓	
		P3.3	Tool, bearing, spring and high-speed steels**	< 1500	✓	✓	✓	
	P4	P4.1	Stainless steels, ferritic and martensitic		✓		✓	
	P5	P5.1	Cast steel		✓		✓	
	P6	P6.1	Stainless cast steel, ferritic and martensitic		✓		✓	
	K	K1	K1.1	Cast iron with lamellar graphite (grey cast iron), GJL	< 300	✓	✓	✓
			K2.1	Cast iron with spheroidal graphite, GJS	< 500	✓	✓	✓
K2		K2.2	Cast iron with spheroidal graphite, GJS	≤ 800	✓	✓	✓	
		K2.3	Cast iron with spheroidal graphite, GJS	> 800	✓	✓	✓	
K3		K3.1	Cast iron with spheroidal graphite, GJV; malleable cast iron, GJM	< 500	✓	✓	✓	
		K3.2	Cast iron with spheroidal graphite, GJV; malleable cast iron, GJM	> 500	✓	✓	✓	
H	H1	H1.1	Hardened steel / cast steel	< 44	✓	✓		
		H1.2	Hardened steel / cast steel	< 55	✓	✓		
	H2	H2.1	Hardened steel / cast steel	< 60	✓			
		H2.2	Hardened steel / cast steel	< 65	✓			
		H2.3	Hardened steel / cast steel	< 68	✓			
	H3	H3.1	Wear-resistant cast/chill casting, GJN		✓	✓		

Working depth correction factor – k_{AT}

AT	k_{AT}		
	a_p	n	v_f
≤ 3xD	1,00	1,00	1,00
≤ 5xD	0,80	0,90	0,90
≤ 6xD	0,70	0,85	0,85
≤ 8xD	0,60	0,75	0,75
≤ 10xD	0,50	0,70	0,70
≤ 12xD	0,45***	0,65	0,65
≤ 15xD	0,40***	0,60	0,60
≤ 20xD	0,35***	0,60	0,60
≤ 25xD	0,35***	0,50	0,50
≤ 30xD	0,30***	0,50	0,50
≤ 35xD	0,30***	0,50	0,50

Cone angle correction factor – k_{KW}

φ [°]	k_{KW}		
	a_p	n	v_f
0	1,00	1,00	1,00
0,5	1,01	1,01	1,01
1	1,02	1,02	1,02
1,5	1,03	1,03	1,03
3	1,06	1,06	1,06

* MAPAL machining groups

** If the alloy parts Cr, Mo, Ni, V, W in total > 8%, then select the next highest MAPAL machining group.

*** Consultation with a MAPAL application engineer.

Roughing

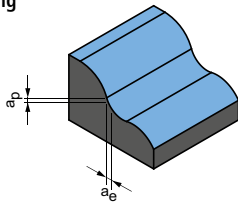

Plunge angle
1.0 ° - 3.0 °

Next page:
Finishing

a _p [mm] in % of D	a _e [mm] in % of D	V _c [m/min]	f _z [mm]																			
			Diameter of milling cutter [mm]																			
			0.10	0.20	0.30	0.40	0.50	0.60	0.80	1.00	1.50	1.80	2.00	2.50	3.00	4.00	5.00	6.00	8.00	10.00	12.00	16.00
5	< 25	250-300	0.003	0.004	0.006	0.008	0.010	0.012	0.016	0.020	0.028	0.035	0.040	0.050	0.061	0.084	0.107	0.125	0.165	0.200	0.235	0.300
4.5	< 25	240-280	0.003	0.004	0.005	0.007	0.009	0.011	0.014	0.018	0.025	0.031	0.035	0.044	0.054	0.074	0.094	0.110	0.145	0.176	0.207	0.264
5	< 25	250-300	0.003	0.004	0.006	0.008	0.010	0.012	0.016	0.020	0.028	0.035	0.040	0.050	0.061	0.084	0.107	0.125	0.165	0.200	0.235	0.300
4.5	< 25	240-280	0.003	0.004	0.005	0.007	0.009	0.011	0.014	0.018	0.025	0.031	0.035	0.044	0.054	0.074	0.094	0.110	0.145	0.176	0.207	0.264
5	< 25	250-300	0.003	0.004	0.006	0.008	0.010	0.011	0.015	0.019	0.027	0.033	0.038	0.048	0.058	0.080	0.102	0.119	0.157	0.190	0.223	0.285
4.5	< 20	240-280	0.003	0.004	0.005	0.007	0.009	0.011	0.014	0.018	0.025	0.031	0.035	0.044	0.054	0.074	0.094	0.110	0.145	0.176	0.207	0.264
4	< 20	220-260	0.002	0.003	0.004	0.006	0.007	0.009	0.012	0.015	0.020	0.026	0.029	0.037	0.045	0.061	0.078	0.091	0.120	0.146	0.172	0.219
5	< 25	240-280	0.003	0.004	0.006	0.008	0.010	0.012	0.016	0.020	0.028	0.035	0.040	0.050	0.061	0.084	0.107	0.125	0.165	0.200	0.235	0.300
5	< 25	240-280	0.003	0.004	0.005	0.007	0.009	0.011	0.014	0.018	0.025	0.031	0.035	0.044	0.054	0.074	0.094	0.110	0.145	0.176	0.207	0.264
4.5	< 25	200-250	0.002	0.003	0.004	0.006	0.007	0.009	0.012	0.015	0.020	0.026	0.029	0.037	0.045	0.061	0.078	0.091	0.120	0.146	0.172	0.219
6	< 30	250-300	0.004	0.005	0.007	0.010	0.012	0.014	0.019	0.024	0.034	0.042	0.048	0.060	0.073	0.101	0.128	0.150	0.198	0.240	0.282	0.360
6	< 30	250-300	0.003	0.004	0.006	0.008	0.010	0.012	0.016	0.020	0.028	0.035	0.040	0.050	0.061	0.084	0.107	0.125	0.165	0.200	0.235	0.300
6	< 30	240-280	0.003	0.004	0.006	0.008	0.010	0.012	0.016	0.020	0.028	0.035	0.040	0.050	0.061	0.084	0.107	0.125	0.165	0.200	0.235	0.300
6	< 30	240-280	0.003	0.004	0.005	0.007	0.009	0.011	0.014	0.018	0.025	0.031	0.035	0.044	0.054	0.074	0.094	0.110	0.145	0.176	0.207	0.264
6	< 30	250-300	0.002	0.003	0.004	0.006	0.007	0.009	0.012	0.015	0.020	0.026	0.029	0.037	0.045	0.061	0.078	0.091	0.120	0.146	0.172	0.219
6	< 30	240-280	0.002	0.002	0.004	0.005	0.006	0.007	0.010	0.012	0.017	0.022	0.025	0.031	0.038	0.052	0.066	0.078	0.102	0.124	0.146	0.186
4	< 18	220-280	0.002	0.003	0.004	0.006	0.007	0.009	0.012	0.015	0.020	0.026	0.029	0.037	0.045	0.061	0.078	0.091	0.120	0.146	0.172	0.219
3	< 12	160-220	0.002	0.002	0.004	0.005	0.006	0.007	0.010	0.012	0.017	0.021	0.024	0.030	0.037	0.050	0.064	0.075	0.099	0.120	0.141	0.180
1.5	< 3	100-160	0.001	0.002	0.002	0.003	0.004	0.005	0.006	0.008	0.011	0.014	0.016	0.020	0.024	0.034	0.043	0.050	0.066	0.080	0.094	0.120
0.8	< 1.8	60-100	0.001	0.001	0.002	0.002	0.003	0.004	0.005	0.006	0.008	0.011	0.012	0.015	0.018	0.025	0.032	0.038	0.050	0.060	0.071	0.090
0.5	< 1.5	40-80	0.001	0.001	0.001	0.002	0.002	0.003	0.004	0.004	0.006	0.008	0.009	0.011	0.013	0.019	0.024	0.028	0.036	0.044	0.052	0.066
1.5	< 3	100-160	0.001	0.002	0.002	0.003	0.004	0.005	0.006	0.008	0.011	0.014	0.016	0.020	0.024	0.034	0.043	0.050	0.066	0.080	0.094	0.120

The specified machining values are guide values.
The optimum data for the respective machining task should be determined during the test or machining.

Cutting data recommendations for Ball nose milling cutter

Feed and cutting speed

OptiMill-3D-BN-Hardened | MBN107

MMG*		Workpiece material	Strength/hardness [N/mm ²] [HRC]	Cooling			
				ML/Air	Dry	Coolant	
P	P1	P1.1 Structural, free-cutting, case hardened and heat-treated steels, non-alloy	< 700	✓	✓	✓	
		P1.2 Structural, free-cutting, case hardened and heat-treated steels, non-alloy	< 1200	✓	✓	✓	
	P2	P2.1 Nitrided, case hardened and heat-treated steels, alloy	< 900	✓	✓	✓	
		P2.2 Nitrided, case hardened and heat-treated steels, alloy	< 1400	✓	✓	✓	
	P3	P3.1 Tool, bearing, spring and high-speed steels**	< 800	✓	✓	✓	
		P3.2 Tool, bearing, spring and high-speed steels**	< 1000	✓	✓	✓	
		P3.3 Tool, bearing, spring and high-speed steels**	< 1500	✓	✓	✓	
	P4	P4.1 Stainless steels, ferritic and martensitic		✓		✓	
	P5	P5.1 Cast steel		✓		✓	
	P6	P6.1 Stainless cast steel, ferritic and martensitic		✓		✓	
	K	K1	K1.1 Cast iron with lamellar graphite (grey cast iron), GJL	< 300	✓	✓	✓
			K2.1 Cast iron with spheroidal graphite, GJS	< 500	✓	✓	✓
K2		K2.2 Cast iron with spheroidal graphite, GJS	≤ 800	✓	✓	✓	
		K2.3 Cast iron with spheroidal graphite, GJS	> 800	✓	✓	✓	
K3		K3.1 Cast iron with spheroidal graphite, GJV; malleable cast iron, GJM	< 500	✓	✓	✓	
		K3.2 Cast iron with spheroidal graphite, GJV; malleable cast iron, GJM	> 500	✓	✓	✓	
H	H1	H1.1 Hardened steel / cast steel	< 44	✓	✓		
		H1.2 Hardened steel / cast steel	< 55	✓	✓		
	H2	H2.1 Hardened steel / cast steel	< 60	✓			
		H2.2 Hardened steel / cast steel	< 65	✓			
		H2.3 Hardened steel / cast steel	< 68	✓			
	H3	H3.1 Wear-resistant cast/chill casting, GJN		✓	✓		

Working depth correction factor – k_{AT}

AT	k_{AT}		
	a_p	n	v_f
≤ 3xD	1,00	1,00	1,00
≤ 5xD	0,80	0,90	0,90
≤ 6xD	0,70	0,85	0,85
≤ 8xD	0,60	0,75	0,75
≤ 10xD	0,50	0,70	0,70
≤ 12xD	0,45***	0,65	0,65
≤ 15xD	0,40***	0,60	0,60
≤ 20xD	0,35***	0,60	0,60
≤ 25xD	0,35***	0,50	0,50
≤ 30xD	0,30***	0,50	0,50
≤ 35xD	0,30***	0,50	0,50

Cone angle correction factor – k_{KW}

φ [°]	k_{KW}		
	a_p	n	v_f
0	1,00	1,00	1,00
0,5	1,01	1,01	1,01
1	1,02	1,02	1,02
1,5	1,03	1,03	1,03
3	1,06	1,06	1,06

* MAPAL machining groups

** If the alloy parts Cr, Mo, Ni, V, W in total > 8%, then select the next highest MAPAL machining group.

*** Consultation with a MAPAL application engineer.

Finishing

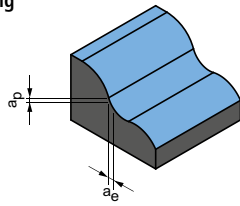

Plunge angle
0.5° - 1.0°

a_p [mm] in % of D	a_e [mm] in % of D	v_c [m/min]	f_z [mm]																			
			Diameter of milling cutter [mm]																			
			0.10	0.20	0.30	0.40	0.50	0.60	0.80	1.00	1.50	1.80	2.00	2.50	3.00	4.00	5.00	6.00	8.00	10.00	12.00	16.00
1.5	2.5	280-340	0.003	0.004	0.006	0.008	0.010	0.011	0.015	0.019	0.027	0.033	0.038	0.048	0.058	0.080	0.102	0.119	0.157	0.190	0.223	0.285
1.4	2.4	280-320	0.003	0.003	0.005	0.007	0.008	0.010	0.013	0.017	0.023	0.029	0.033	0.042	0.051	0.070	0.089	0.105	0.138	0.167	0.196	0.251
1.4	2.4	270-320	0.003	0.004	0.006	0.008	0.010	0.011	0.015	0.019	0.027	0.033	0.038	0.048	0.058	0.080	0.102	0.119	0.157	0.190	0.223	0.285
1.3	2.3	260-300	0.003	0.003	0.005	0.007	0.008	0.010	0.013	0.017	0.023	0.029	0.033	0.042	0.051	0.070	0.089	0.105	0.138	0.167	0.196	0.251
1.3	2.3	280-320	0.003	0.004	0.005	0.007	0.009	0.011	0.014	0.018	0.025	0.032	0.036	0.045	0.055	0.076	0.097	0.113	0.149	0.181	0.212	0.271
1.2	2.2	260-300	0.003	0.003	0.005	0.007	0.008	0.010	0.013	0.017	0.023	0.029	0.033	0.042	0.051	0.070	0.089	0.105	0.138	0.167	0.196	0.251
1	2	240-280	0.002	0.003	0.004	0.006	0.007	0.008	0.011	0.014	0.019	0.024	0.028	0.035	0.042	0.058	0.074	0.087	0.114	0.139	0.163	0.208
1.3	2.3	260-300	0.003	0.004	0.006	0.008	0.010	0.011	0.015	0.019	0.027	0.033	0.038	0.048	0.058	0.080	0.102	0.119	0.157	0.190	0.223	0.285
1.3	2.3	260-300	0.003	0.003	0.005	0.007	0.008	0.010	0.013	0.017	0.023	0.029	0.033	0.042	0.051	0.070	0.089	0.105	0.138	0.167	0.196	0.251
1.2	2.2	220-270	0.002	0.003	0.004	0.006	0.007	0.008	0.011	0.014	0.019	0.024	0.028	0.035	0.042	0.058	0.074	0.087	0.114	0.139	0.163	0.208
1.5	2.5	280-340	0.003	0.004	0.006	0.008	0.010	0.011	0.015	0.019	0.027	0.033	0.038	0.048	0.058	0.080	0.102	0.119	0.157	0.190	0.223	0.285
1.4	2.4	280-320	0.003	0.003	0.005	0.007	0.008	0.010	0.013	0.017	0.023	0.029	0.033	0.042	0.051	0.070	0.089	0.105	0.138	0.167	0.196	0.251
1.3	2.3	270-320	0.003	0.003	0.005	0.007	0.008	0.010	0.013	0.017	0.023	0.029	0.033	0.042	0.051	0.070	0.089	0.105	0.138	0.167	0.196	0.251
1.2	2.2	260-300	0.003	0.003	0.005	0.007	0.008	0.010	0.013	0.017	0.023	0.029	0.033	0.042	0.051	0.070	0.089	0.105	0.138	0.167	0.196	0.251
1.4	2.4	280-320	0.002	0.003	0.004	0.006	0.007	0.008	0.011	0.014	0.019	0.024	0.028	0.035	0.042	0.058	0.074	0.087	0.114	0.139	0.163	0.208
1.3	2.3	260-300	0.002	0.002	0.004	0.005	0.006	0.007	0.009	0.012	0.017	0.021	0.024	0.029	0.036	0.050	0.063	0.074	0.097	0.118	0.139	0.177
1.2	2.2	250-300	0.003	0.004	0.005	0.007	0.009	0.011	0.015	0.018	0.026	0.032	0.037	0.046	0.056	0.077	0.098	0.114	0.151	0.183	0.215	0.274
1	2	200-250	0.002	0.003	0.005	0.007	0.008	0.010	0.013	0.017	0.023	0.029	0.033	0.041	0.051	0.070	0.089	0.104	0.137	0.166	0.195	0.249
0.8	1.8	130-200	0.002	0.003	0.005	0.006	0.008	0.009	0.012	0.015	0.021	0.026	0.030	0.038	0.046	0.063	0.081	0.094	0.124	0.151	0.177	0.226
0.6	1.6	100-150	0.002	0.003	0.004	0.005	0.007	0.008	0.011	0.014	0.019	0.024	0.027	0.034	0.042	0.058	0.073	0.086	0.113	0.137	0.161	0.206
0.5	1.5	70-120	0.001	0.002	0.003	0.004	0.005	0.006	0.008	0.010	0.013	0.017	0.019	0.024	0.029	0.040	0.051	0.060	0.079	0.096	0.113	0.144
0.8	1.8	130-200	0.002	0.003	0.005	0.006	0.008	0.009	0.012	0.015	0.021	0.026	0.030	0.038	0.046	0.063	0.081	0.094	0.124	0.151	0.177	0.226

The specified machining values are guide values.
The optimum data for the respective machining task should be determined during the test or machining.

Cutting data recommendations for Ball nose milling cutter

Feed and cutting speed

Correction factor:	
Length	f_z & v_c
A/B	1,0
C	0,9
D	0,7
E	0,6

Finishing

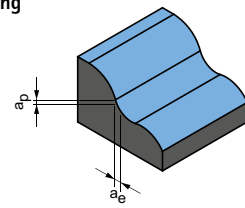

$$a_p = 0.1 \times D$$

$$a_e = 0.1 \times D$$

CPMill-Uni-Radius | CPM150

MMG*		Workpiece material	Strength/hardness [N/mm ²] [HRC]	Cooling			
				MQL/Air	Dry	Coolant	
P	P1	P1.1	Structural, free-cutting, case hardened and heat-treated steels, non-alloy	< 700	✓	✓	✓
		P1.2	Structural, free-cutting, case hardened and heat-treated steels, non-alloy	< 1200	✓	✓	✓
	P2	P2.1	Nitrided, case hardened and heat-treated steels, alloy	< 900	✓	✓	✓
		P2.2	Nitrided, case hardened and heat-treated steels, alloy	< 1400	✓		✓
	P3	P3.1	Tool, bearing, spring and high-speed steels**	< 800	✓	✓	✓
		P3.2	Tool, bearing, spring and high-speed steels**	< 1000	✓		✓
		P3.3	Tool, bearing, spring and high-speed steels**	< 1500	✓		✓
P5	P5.1	Cast steel				✓	
K	K1	K1.1	Cast iron with lamellar graphite (grey cast iron), GJL	< 300	✓	✓	✓
		K2.1	Cast iron with spheroidal graphite, GJS	< 500	✓	✓	✓
	K2	K2.2	Cast iron with spheroidal graphite, GJS	500-800	✓	✓	✓
		K2.3	Cast iron with spheroidal graphite, GJS	> 800	✓	✓	✓
	K3	K3.1	Cast iron with spheroidal graphite, GJV; malleable cast iron, GJM	< 500	✓	✓	✓
		K3.2	Cast iron with spheroidal graphite, GJV; malleable cast iron, GJM	> 500	✓	✓	✓
N	N1	N1.1	Aluminium, non-alloy and alloy < 3 % Si		✓	✓	✓
		N1.2	Aluminium, alloy ≤ 7 % Si		✓	✓	✓
		N1.3	Aluminium, alloy > 7-12 % Si		✓	✓	✓
		N1.4	Aluminium, alloy > 12 % Si		✓	✓	✓
	N2	N2.1	Copper, non-alloy and low-alloy	< 300	✓	✓	✓
		N2.2	Copper, alloy	> 300	✓	✓	✓
		N2.3	Brass, bronze, gunmetal	< 1200	✓	✓	✓

OptiMill-Diamond-Radius | SHM521

MMG*		Workpiece material	Strength/hardness [N/mm ²] [HRC]	Cooling			
				MQL/Air	Dry	Coolant	
N	N1	N1.1	Aluminium, non-alloy and alloy < 3 % Si	✓	✓	✓	
		N1.2	Aluminium, alloy ≤ 7 % Si	✓	✓	✓	
		N1.3	Aluminium, alloy > 7-12 % Si	✓	✓	✓	
		N1.4	Aluminium, alloy > 12 % Si	✓	✓	✓	
	N2	N2.1	Copper, non-alloy and low-alloy	< 300	✓	✓	✓
		N2.2	Copper, alloy	> 300	✓	✓	✓
		N2.3	Brass, bronze, gunmetal	< 1200	✓	✓	✓
N4	N4.1	Plastic, thermoplastics					
	N4.2	Plastic, thermosets		✓	✓		
	N4.3	Plastic, foams					
C	C1	C1.1	Plastic matrix, aramide fibre-reinforced (AFRP)	✓	✓	✓	
		C1.2	Plastic matrix (thermosetting), CFRP/GFRP	✓	✓	✓	
		C1.3	Plastic matrix (thermoplastic), CFRP/GFRP	✓	✓	✓	
	C2	C2.1	Carbon matrix, carbon fibre-reinforced (CFC)	✓	✓	✓	

* MAPAL machining groups

** If the alloy parts Cr, Mo, Ni, V, W in total > 8%, then select the next highest MAPAL machining group.

	v_c [m/min]	f_z [mm]					
		Diameter of milling cutter [mm]					
		8.00	10.00	12.00	16.00	20.00	25.00
	240	0.052	0.063	0.072	0.088	0.100	0.112
	195	0.049	0.058	0.067	0.082	0.094	0.105
	220	0.052	0.063	0.072	0.088	0.100	0.112
	155	0.044	0.052	0.060	0.073	0.084	0.093
	140	0.050	0.060	0.069	0.085	0.097	0.108
	130	0.048	0.057	0.066	0.080	0.092	0.103
	120	0.045	0.054	0.062	0.076	0.087	0.097
	145	0.050	0.060	0.069	0.085	0.097	0.108
	325	0.087	0.104	0.120	0.146	0.167	0.187
	295	0.074	0.089	0.102	0.124	0.142	0.159
	245	0.061	0.073	0.084	0.102	0.117	0.131
	135	0.035	0.042	0.048	0.059	0.067	0.075
	215	0.061	0.073	0.084	0.102	0.117	0.131
	205	0.052	0.063	0.072	0.088	0.100	0.112
	705	0.064	0.077	0.089	0.108	0.124	0.138
	470	0.068	0.081	0.093	0.114	0.130	0.145
	375	0.071	0.085	0.097	0.119	0.136	0.152
	270	0.077	0.093	0.106	0.130	0.149	0.166
	270	0.052	0.062	0.071	0.087	0.099	0.111
	200	0.052	0.062	0.071	0.087	0.099	0.111
	335	0.032	0.039	0.044	0.054	0.062	0.069

	Diameter of milling cutter [mm]					
	3.00 - 6.00		8.00 - 10.00		12.00 - 16.00	
	v_c [m/min]	f_z [mm]	v_c [m/min]	f_z [mm]	v_c [m/min]	f_z [mm]
	300	0.12 - 0.15	600	0.15 - 0.20	900	0.20 - 0.25
	300	0.12 - 0.15	600	0.15 - 0.20	900	0.20 - 0.25
	300	0.12 - 0.15	600	0.15 - 0.20	900	0.20 - 0.25
	300	0.12 - 0.15	600	0.15 - 0.20	900	0.20 - 0.25
	300	0.12 - 0.15	600	0.15 - 0.20	900	0.20 - 0.25
	300	0.12 - 0.15	600	0.15 - 0.20	900	0.20 - 0.25
	300	0.12 - 0.15	600	0.15 - 0.20	900	0.20 - 0.25
	300	0.12 - 0.15	600	0.15 - 0.20	900	0.20 - 0.25
	300	0.12 - 0.15	600	0.15 - 0.20	900	0.20 - 0.25
	300	0.12 - 0.15	600	0.15 - 0.20	900	0.20 - 0.25
	300	0.12 - 0.15	600	0.15 - 0.20	900	0.20 - 0.25

The specified machining values are guide values.

The optimum data for the respective machining task should be determined during the test or machining.

Cutting data recommendations for corner radius milling cutters

Feed and cutting speed

Correction factor:	
Length	f_z & v_c
A/B	1,0
C	0,9
D	0,7
E	0,6

CPMill-Uni-Torus | CPM160

MMG*		Workpiece material	Strength/hardness [N/mm ²] [HRC]	Cooling		
				MQL/Air	Dry	Coolant
P	P1	P1.1 Structural, free-cutting, case hardened and heat-treated steels, non-alloy	< 700	✓	✓	✓
		P1.2 Structural, free-cutting, case hardened and heat-treated steels, non-alloy	< 1200	✓	✓	✓
	P2	P2.1 Nitrided, case hardened and heat-treated steels, alloy	< 900	✓	✓	✓
		P2.2 Nitrided, case hardened and heat-treated steels, alloy	< 1400	✓		✓
	P3	P3.1 Tool, bearing, spring and high-speed steels**	< 800	✓	✓	✓
		P3.2 Tool, bearing, spring and high-speed steels**	< 1000	✓		✓
		P3.3 Tool, bearing, spring and high-speed steels**	< 1500	✓		✓
	P5	P5.1 Cast steel				✓
K	K1	K1.1 Cast iron with lamellar graphite (grey cast iron), GJL	< 300	✓	✓	✓
		K2.1 Cast iron with spheroidal graphite, GJS	< 500	✓	✓	✓
	K2	K2.2 Cast iron with spheroidal graphite, GJS	500-800	✓	✓	✓
		K2.3 Cast iron with spheroidal graphite, GJS	> 800	✓	✓	✓
	K3	K3.1 Cast iron with spheroidal graphite, GJV; malleable cast iron, GJM	< 500	✓	✓	✓
		K3.2 Cast iron with spheroidal graphite, GJV; malleable cast iron, GJM	> 500	✓	✓	✓
N	N1	N1.1 Aluminium, non-alloy and alloy < 3 % Si		✓	✓	✓
		N1.2 Aluminium, alloy ≤ 7 % Si		✓	✓	✓
		N1.3 Aluminium, alloy > 7-12 % Si		✓	✓	✓
		N1.4 Aluminium, alloy > 12 % Si		✓	✓	✓
	N2	N2.1 Copper, non-alloy and low-alloy	< 300	✓	✓	✓
		N2.2 Copper, alloy	> 300	✓	✓	✓
		N2.3 Brass, bronze, gunmetal	< 1200	✓	✓	✓

* MAPAL machining groups

** If the alloy parts Cr, Mo, Ni, V, W in total > 8%, then select the next highest MAPAL machining group.

Roughing

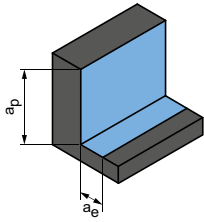

$$a_p = 0.56 \times D$$

$$a_e = 0.5 \times D$$

Finishing

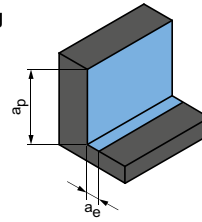

$$a_p = 0.56 \times D$$

$$a_e = 0.1 \times D$$

	v_c [m/min]	f_z [mm]						v_c [m/min]	f_z [mm]					
		Diameter of milling cutter [mm]							Diameter of milling cutter [mm]					
		8.00	10.00	12.00	16.00	20.00	25.00		8.00	10.00	12.00	16.00	20.00	25.00
	125	0.015	0.018	0.021	0.026	0.029	0.033	240	0.034	0.041	0.047	0.057	0.066	0.073
	105	0.014	0.017	0.020	0.024	0.027	0.031	195	0.032	0.038	0.044	0.054	0.061	0.068
	115	0.015	0.018	0.021	0.026	0.029	0.033	220	0.034	0.041	0.047	0.057	0.066	0.073
	80	0.013	0.015	0.018	0.021	0.024	0.027	155	0.028	0.034	0.039	0.048	0.055	0.061
	75	0.015	0.018	0.020	0.025	0.028	0.032	140	0.033	0.040	0.045	0.055	0.063	0.071
	70	0.014	0.017	0.019	0.024	0.027	0.030	130	0.031	0.037	0.043	0.053	0.060	0.067
	65	0.013	0.016	0.018	0.022	0.025	0.028	120	0.030	0.035	0.041	0.050	0.057	0.063
	75	0.015	0.018	0.020	0.025	0.028	0.032	145	0.033	0.040	0.045	0.055	0.063	0.071
	140	0.025	0.030	0.035	0.043	0.049	0.055	325	0.057	0.068	0.078	0.096	0.109	0.122
	125	0.022	0.026	0.030	0.036	0.042	0.046	295	0.048	0.058	0.067	0.081	0.093	0.104
	105	0.018	0.021	0.025	0.030	0.034	0.038	245	0.040	0.048	0.055	0.067	0.077	0.085
	60	0.010	0.012	0.014	0.017	0.020	0.022	135	0.023	0.027	0.031	0.038	0.044	0.049
	90	0.018	0.021	0.025	0.030	0.034	0.038	215	0.040	0.048	0.055	0.067	0.077	0.085
	85	0.015	0.018	0.021	0.026	0.029	0.033	205	0.034	0.041	0.047	0.057	0.066	0.073
	470	0.024	0.028	0.032	0.040	0.045	0.050	705	0.042	0.050	0.058	0.071	0.081	0.090
	315	0.025	0.030	0.034	0.042	0.048	0.053	470	0.044	0.053	0.061	0.074	0.085	0.095
	250	0.026	0.031	0.036	0.044	0.050	0.056	375	0.046	0.055	0.064	0.078	0.089	0.099
	180	0.028	0.034	0.039	0.047	0.054	0.061	270	0.050	0.060	0.069	0.085	0.097	0.108
	180	0.019	0.023	0.026	0.032	0.036	0.040	270	0.034	0.040	0.046	0.057	0.065	0.072
	135	0.019	0.023	0.026	0.032	0.036	0.040	200	0.034	0.040	0.046	0.057	0.065	0.072
	225	0.012	0.014	0.016	0.020	0.023	0.025	335	0.021	0.025	0.029	0.035	0.040	0.045

The specified machining values are guide values.
The optimum data for the respective machining task should be determined during the test or machining.

Cutting data recommendations for corner radius milling cutters

Feed and cutting speed

Groove milling

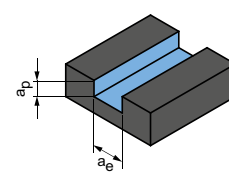

$$a_p = 0.5xD$$

$$a_e = 1xD$$

OptiMill-Diamond-Torus | SHM551

MMG*	Workpiece material	Strength/hardness [N/mm ²] [HRC]	Cooling			Diameter of milling cutter [mm]						
			MQL/Air	Dry	Coolant	3.00 - 6.00		8.00 - 10.00		12.00		
						v _c [m/min]	f _z [mm]	v _c [m/min]	f _z [mm]	v _c [m/min]	f _z [mm]	
N	N1	N1.1 Aluminium, non-alloy and alloy < 3 % Si	✓	✓	✓	200	0.10-0.12	500	0.12-0.18	800	0.15-0.20	
		N1.2 Aluminium, alloy ≤ 7 % Si	✓	✓	✓	200	0.10-0.12	500	0.12-0.18	800	0.15-0.20	
		N1.3 Aluminium, alloy > 7-12 % Si	✓	✓	✓	200	0.10-0.12	500	0.12-0.18	800	0.15-0.20	
		N1.4 Aluminium, alloy > 12 % Si	✓	✓	✓	200	0.10-0.12	500	0.12-0.18	800	0.15-0.20	
	N2	N2.1 Copper, non-alloy and low-alloy	< 300	✓	✓	✓	200	0.10-0.12	500	0.12-0.18	800	0.15-0.20
		N2.2 Copper, alloy	> 300	✓	✓	✓	200	0.10-0.12	500	0.12-0.18	800	0.15-0.20
		N2.3 Brass, bronze, gunmetal	< 1.200	✓	✓	✓	200	0.10-0.12	500	0.12-0.18	800	0.15-0.20
	N4	N4.1 Plastic, thermoplastics										
		N4.2 Plastic, thermosets		✓	✓	✓	200	0.10-0.12	500	0.12-0.18	800	0.15-0.20
		N4.3 Plastic, foams										
C	C1.1 Plastic matrix, aramide fibre-reinforced (AFRP)											
	C1.2 Plastic matrix (thermosetting), CFRP/GFRP		✓	✓	✓	200	0.10-0.12	500	0.12-0.18	800	0.15-0.20	
	C1.3 Plastic matrix (thermoplastic), CFRP/GFRP		✓	✓	✓	200	0.10-0.12	500	0.12-0.18	800	0.15-0.20	
	C2.1 Carbon matrix, carbon fibre-reinforced (CFC)		✓	✓	✓	200	0.10-0.12	500	0.12-0.18	800	0.15-0.20	

Groove milling

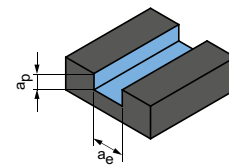

$$a_p = 1xD$$

$$a_e = 1xD$$

OptiMill-Composite-Speed-Radius | SCM870

MMG*	Workpiece material	Strength/hardness [N/mm ²] [HRC]	Cooling			v _c [m/min]	f _z [mm]						
			MQL/Air	Dry	Coolant		Diameter of milling cutter [mm]						
							4.00	6.00	8.00	10.00	12.00	16.00	20.00
N	N4	N4.1 Plastic, thermoplastics											
		N4.2 Plastic, thermosets	✓	✓	✓	150	0.020	0.029	0.038	0.045	0.052	0.063	0.072
		N4.3 Plastic, foams											
C	C1	C1.1 Plastic matrix, aramide fibre-reinforced (AFRP)											
		C1.2 Plastic matrix (thermosetting), CFRP/GFRP	✓	✓	✓	145	0.021	0.026	0.031	0.035	0.038	0.042	0.043
		C1.3 Plastic matrix (thermoplastic), CFRP/GFRP											
	C2	C2.1 Carbon matrix, carbon fibre-reinforced (CFC)	✓	✓	✓	145	0.018	0.023	0.027	0.031	0.033	0.037	0.038
		C3.1 Metal matrix (MMC)											
	C4	C4.1 Sandwich construction, honeycomb core	✓	✓		195	0.012	0.015	0.017	0.019	0.021	0.023	0.024
		C4.2 Sandwich construction, foam core	✓	✓		150	0.019	0.024	0.028	0.032	0.035	0.039	0.041

* MAPAL machining groups

Roughing

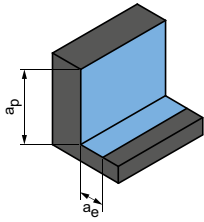

$$a_p = 0.5 \times D$$

$$a_e = 0.25 \times D$$

Finishing

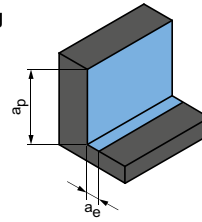

$$a_p = 0.5 \times D$$

$$a_e = 0.1 \times D$$

		Diameter of milling cutter [mm]						Diameter of milling cutter [mm]					
		3.00 - 6.00		8.00 - 10.00		12.00		3.00 - 6.00		8.00 - 10.00		12.00	
v_c [m/min]	f_z [mm]	v_c [m/min]	f_z [mm]	v_c [m/min]	f_z [mm]	v_c [m/min]	f_z [mm]	v_c [m/min]	f_z [mm]	v_c [m/min]	f_z [mm]	v_c [m/min]	f_z [mm]
240	0.10-0.12	480	0.12-0.16	720	0.16-0.18	300	0.12-0.15	600	0.15-0.20	900	0.20-0.23	240	0.10-0.12
240	0.10-0.12	480	0.12-0.16	720	0.16-0.18	300	0.12-0.15	600	0.15-0.20	900	0.20-0.23	240	0.10-0.12
240	0.10-0.12	480	0.12-0.16	720	0.16-0.18	300	0.12-0.15	600	0.15-0.20	900	0.20-0.23	240	0.10-0.12
240	0.10-0.12	480	0.12-0.16	720	0.16-0.18	300	0.12-0.15	600	0.15-0.20	900	0.20-0.23	240	0.10-0.12
240	0.10-0.12	480	0.12-0.16	720	0.16-0.18	300	0.12-0.15	600	0.15-0.20	900	0.20-0.23	240	0.10-0.12
240	0.10-0.12	480	0.12-0.16	720	0.16-0.18	300	0.12-0.15	600	0.15-0.20	900	0.20-0.23	240	0.10-0.12
240	0.10-0.12	480	0.12-0.16	720	0.16-0.18	300	0.12-0.15	600	0.15-0.20	900	0.20-0.23	240	0.10-0.12
240	0.10-0.12	480	0.12-0.16	720	0.16-0.18	300	0.12-0.15	600	0.15-0.20	900	0.20-0.23	240	0.10-0.12
240	0.10-0.12	480	0.12-0.16	720	0.16-0.18	300	0.12-0.15	600	0.15-0.20	900	0.20-0.23	240	0.10-0.12
240	0.10-0.12	480	0.12-0.16	720	0.16-0.18	300	0.12-0.15	600	0.15-0.20	900	0.20-0.23	240	0.10-0.12
240	0.10-0.12	480	0.12-0.16	720	0.16-0.18	300	0.12-0.15	600	0.15-0.20	900	0.20-0.23	240	0.10-0.12
240	0.10-0.12	480	0.12-0.16	720	0.16-0.18	300	0.12-0.15	600	0.15-0.20	900	0.20-0.23	240	0.10-0.12
240	0.10-0.12	480	0.12-0.16	720	0.16-0.18	300	0.12-0.15	600	0.15-0.20	900	0.20-0.23	240	0.10-0.12
240	0.10-0.12	480	0.12-0.16	720	0.16-0.18	300	0.12-0.15	600	0.15-0.20	900	0.20-0.23	240	0.10-0.12
240	0.10-0.12	480	0.12-0.16	720	0.16-0.18	300	0.12-0.15	600	0.15-0.20	900	0.20-0.23	240	0.10-0.12
240	0.10-0.12	480	0.12-0.16	720	0.16-0.18	300	0.12-0.15	600	0.15-0.20	900	0.20-0.23	240	0.10-0.12
240	0.10-0.12	480	0.12-0.16	720	0.16-0.18	300	0.12-0.15	600	0.15-0.20	900	0.20-0.23	240	0.10-0.12
240	0.10-0.12	480	0.12-0.16	720	0.16-0.18	300	0.12-0.15	600	0.15-0.20	900	0.20-0.23	240	0.10-0.12
240	0.10-0.12	480	0.12-0.16	720	0.16-0.18	300	0.12-0.15	600	0.15-0.20	900	0.20-0.23	240	0.10-0.12

Roughing

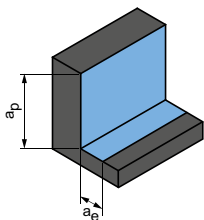

$$a_p = 1.5 \times D$$

$$a_e = 0.25 \times D$$

Finishing

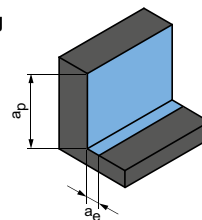

$$a_p = 1.5 \times D$$

$$a_e = 0.1 \times D$$

v_c [m/min]	f_z [mm]								v_c [m/min]	f_z [mm]							
	Diameter of milling cutter [mm]									Diameter of milling cutter [mm]							
	4.00	6.00	8.00	10.00	12.00	16.00	20.00	4.00		6.00	8.00	10.00	12.00	16.00	20.00		
230	0.029	0.041	0.053	0.063	0.072	0.089	0.101	275	0.040	0.057	0.073	0.088	0.101	0.123	0.141		
240	0.021	0.026	0.031	0.035	0.038	0.042	0.043	355	0.021	0.026	0.031	0.035	0.038	0.042	0.043		
240	0.018	0.023	0.027	0.031	0.033	0.037	0.038	355	0.018	0.023	0.027	0.031	0.033	0.037	0.038		
325	0.012	0.015	0.017	0.019	0.021	0.023	0.024	480	0.012	0.015	0.017	0.019	0.021	0.023	0.024		
245	0.019	0.024	0.028	0.032	0.035	0.039	0.041	360	0.019	0.024	0.028	0.032	0.035	0.039	0.041		

The specified machining values are guide values.
The optimum data for the respective machining task should be determined during the test or machining.



CHAMFERING, DEBURRING AND DRILL MILLING

Universal application

OptiMill-Chamfer	206
CPMill-Chamfer	207
CPMill-Chamfer-Twin	208
OptiMill-DrillMill	209

Technical appendix

Cutting data recommendations	210
------------------------------------	-----



OptiMill®-Chamfer

Short design
SCM340

Design:

Diameter of milling cutter: 4.00 - 20.00 mm
 Cutting material: HP214
 Number of cutting edges: 4
 Tip angle: 90°
 Helix angle: 0°

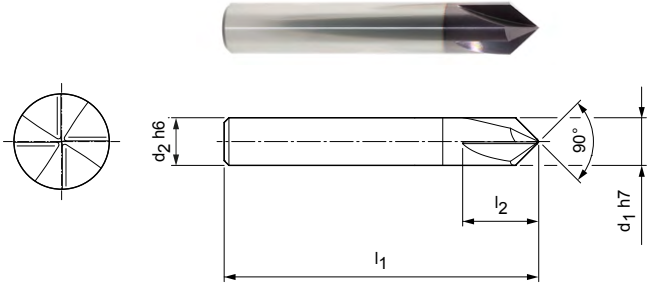

Preferred series in stock

Dimensions				z	Specification	Order no.
d ₁ h7	d ₂ h6	l ₁	l ₂			
4,00	4	54	9	4	SCM340-0400Z04R-HA-HP214	30393635
6,00	6	54	12	4	SCM340-0600Z04R-HA-HP214	30393636
8,00	8	58	15	4	SCM340-0800Z04R-HA-HP214	30393637
10,00	10	66	16	4	SCM340-1000Z04R-HA-HP214	30393638
12,00	12	73	18	4	SCM340-1200Z04R-HA-HP214	30393639
16,00	16	82	25	4	SCM340-1600Z04R-HA-HP214	30393640
20,00	20	92	30	4	SCM340-2000Z04R-HA-HP214	30393641

Configurable features



Shank form:
Shank form: HB



Specification:
SCM340-0400Z04R-[shank form]-HP214

Example:
SCM340-0400Z04R-**HB**-HP214

Shank form HB

Dimensions in mm.
 For cutting data recommendations, see end of chapter.
 Special designs and other coatings available upon request.

CPMill®-Chamfer

Design with CFS connection
CPM180

Design:

Diameter of milling cutter: 8.00 – 20.00 mm
Cutting material: HP338
Number of cutting edges: 4 to ø 12.00 mm
6 from ø 16.00 mm
Helix angle: 0°

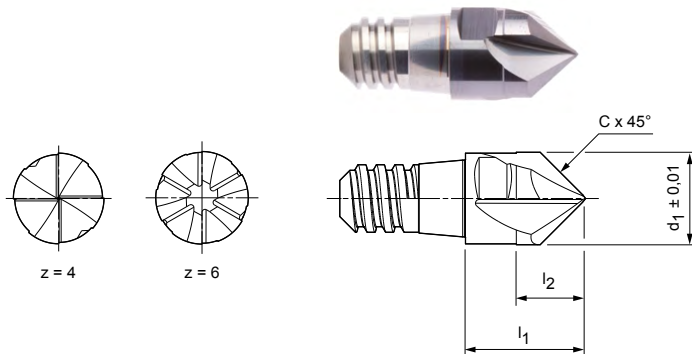

Preferred series in stock

Dimensions					z	a _p max.	SW	Specification	Order no.
d ₁ ± 0.01 mm	CFS size	l ₁	l ₂	Cx45°					
10,00	8	13	7,5	5,00	4	5	SW 8	CPM180-1000Z04-F0500-08-HP338	30371353
12,00	10	16	9	6,00	4	6	SW 10	CPM180-1200Z04-F0600-10-HP338	30371354
16,00	12	20	12	4,80	6	4,8	SW 13	CPM180-1600Z06-F0480-12-HP338	30371355
20,00	16	25	15	6,00	6	6	SW 16	CPM180-2000Z06-F0600-16-HP338	30371357

Available on request

8,00	6	11	6	4,00	4	4	SW 6	CPM180-0800Z04-F0400-06-HP338	30371352
------	---	----	---	------	---	---	------	-------------------------------	----------

Accessories

	CFS replaceable head holders CFS101 CFS201	Page 218
-------------------------------------------------------------------------------------	-------------------------------------------------	----------

Dimensions in mm.

For cutting data recommendations, see end of chapter.

Special designs and other coatings available upon request.

CPMill®-Chamfer-Twin

Design with CFS connection
CPM190

Design:

Diameter of milling cutter: 10.00 – 20.00 mm
 Cutting material: HP383
 Number of cutting edges: 6
 Helix angle: 15°
 Special features: Reverse deburring and chamfering also possible – face side and 45°

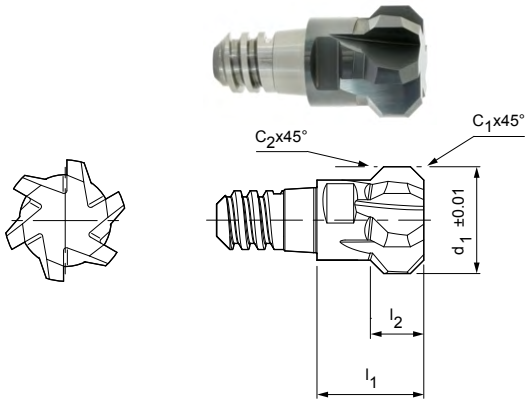

Preferred series in stock

Dimensions						z	ap max.	SW	Specification	Order no.
d1 ± 0.01 mm	CFS size	l1	l2	C1x45°	C2x45°					
10,00	6	11	4,75	1,25	1,00	6	1,25	SW 8	CPM190-1000Z06-F0125-06-HP383	30371346
12,00	8	13	5,5	1,50	1,00	6	1,5	SW 10	CPM190-1200Z06-F0150-08-HP383	30371348
16,00	10	16	8	2,00	2,00	6	2	SW 13	CPM190-1600Z06-F0200-10-HP383	30371349
20,00	12	20	9,5	2,50	2,00	6	2,5	SW 16	CPM190-2000Z06-F0250-12-HP383	30371350

Accessories

	CFS replaceable head holders CFS101 CFS201	Page 218
--	-------------------------------------------------	----------

Dimensions in mm.
 For cutting data recommendations, see end of chapter.
 Special designs and other coatings available upon request.

OptiMill®-DrillMill

Long design with drill tip
SCM350

Design:

Diameter of milling cutter: 3.00 - 16.00 mm
Cutting material: HU211
Number of cutting edges: 2
Tip angle: 90°
Helix angle: 30°

Application:

Drill milling cutter for milling, chamfering, boring and drilling.

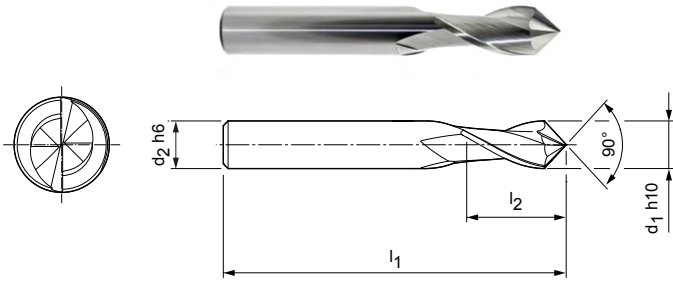

Preferred series in stock

Dimensions				z	Specification	Order no.
d ₁ h10	d ₂ h6	l ₁	l ₂			
3,00	6	57	8	2	SCM350-0300Z02R-HA-HU211	30393642
4,00	6	57	11	2	SCM350-0400Z02R-HA-HU211	30393643
5,00	6	57	13	2	SCM350-0500Z02R-HA-HU211	30393644
6,00	6	57	13	2	SCM350-0600Z02R-HA-HU211	30393645
8,00	8	63	19	2	SCM350-0800Z02R-HA-HU211	30393646
10,00	10	72	22	2	SCM350-1000Z02R-HA-HU211	30393647
12,00	12	83	26	2	SCM350-1200Z02R-HA-HU211	30393648
16,00	16	92	32	2	SCM350-1600Z02R-HA-HU211	30393649

Configurable features



Shank form:
Shank form: HB



Specification:
SCM350-0300Z02R-[shank form]-HU211

Example:

SCM350-0300Z02R-**HB**-HU211

Shank form HB

Dimensions in mm.

For cutting data recommendations, see end of chapter.

Special designs and other coatings available upon request.

Cutting data recommendation for radius and deburring milling cutter

Feed and cutting speed

OptiMill-Chamfer | SCM340

MMG*	Workpiece material	Strength/hardness [N/mm ²] [HRC]	Cooling			
			MQL/Air	Dry	Coolant	
P	P1.1	Structural, free-cutting, case hardened and heat-treated steels, non-alloy	< 700	✓	✓	✓
	P1.2	Structural, free-cutting, case hardened and heat-treated steels, non-alloy	< 1200	✓	✓	✓
	P2.1	Nitrided, case hardened and heat-treated steels, alloy	< 900	✓	✓	✓
	P2.2	Nitrided, case hardened and heat-treated steels, alloy	< 1400	✓		✓
	P3.1	Tool, bearing, spring and high-speed steels**	< 800	✓	✓	✓
	P3.2	Tool, bearing, spring and high-speed steels**	< 1000	✓		✓
	P3.3	Tool, bearing, spring and high-speed steels**	< 1500	✓		✓
	P4.1	Stainless steels, ferritic and martensitic		✓		✓
	P5.1	Cast steel				✓
	P6.1	Stainless cast steel, ferritic and martensitic				✓
M	M1.1	Stainless steels, austenitic	< 700	✓		✓
	M1.2	Stainless steels, ferritic/austenitic (duplex)	< 1000			✓
	M2.1	Stainless/heat-resistant cast steel, austenitic	< 700	✓		✓
	M3.1	Stainless cast steel, ferritic/austenitic (duplex)	< 1000			✓
K	K1.1	Cast iron with lamellar graphite (grey cast iron), GJL	< 300	✓	✓	✓
	K2.1	Cast iron with spheroidal graphite, GJS	< 500	✓	✓	✓
	K2.2	Cast iron with spheroidal graphite, GJS	500-800	✓	✓	✓
	K2.3	Cast iron with spheroidal graphite, GJS	> 800	✓	✓	✓
	K3.1	Cast iron with spheroidal graphite, GJV; malleable cast iron, GJM	< 500	✓	✓	✓
	K3.2	Cast iron with spheroidal graphite, GJV; malleable cast iron, GJM	> 500	✓	✓	✓
N	N1.1	Aluminium, non-alloy and alloy < 3 % Si		✓	✓	✓
	N1.2	Aluminium, alloy ≤ 7 % Si		✓	✓	✓
	N1.3	Aluminium, alloy > 7-12 % Si		✓	✓	✓
	N1.4	Aluminium, alloy > 12 % Si		✓	✓	✓
	N2.1	Copper, non-alloy and low-alloy	< 300	✓	✓	✓
	N2.2	Copper, alloy	> 300	✓	✓	✓
	N2.3	Brass, bronze, gunmetal	< 1200	✓	✓	✓

* MAPAL machining groups

** If the alloy parts Cr, Mo, Ni, V, W in total > 8%, then select the next highest MAPAL machining group.

Finishing

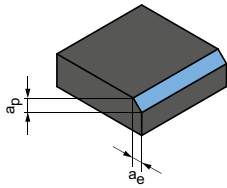

$$a_p = 0.1 \times D$$

$$a_e = 0.1 \times D$$

	v_c [m/min]	f_z [mm]						
		Diameter of milling cutter [mm]						
		4.00	6.00	8.00	10.00	12.00	16.00	20.00
	215	0.043	0.061	0.078	0.094	0.108	0.132	0.151
	175	0.040	0.057	0.073	0.088	0.101	0.123	0.141
	195	0.043	0.061	0.078	0.094	0.108	0.132	0.151
	140	0.036	0.051	0.065	0.078	0.090	0.110	0.125
	130	0.041	0.059	0.076	0.091	0.104	0.127	0.146
	120	0.039	0.056	0.072	0.086	0.099	0.121	0.138
	110	0.037	0.053	0.068	0.081	0.093	0.114	0.131
	90	0.028	0.041	0.052	0.063	0.072	0.088	0.100
	130	0.041	0.059	0.076	0.091	0.104	0.127	0.146
	90	0.020	0.029	0.037	0.044	0.050	0.061	0.070
	75	0.025	0.036	0.046	0.055	0.063	0.077	0.088
	70	0.021	0.030	0.038	0.045	0.052	0.064	0.073
	80	0.027	0.039	0.050	0.059	0.068	0.083	0.095
	75	0.021	0.031	0.039	0.047	0.054	0.066	0.075
	290	0.071	0.102	0.131	0.156	0.180	0.220	0.251
	265	0.060	0.087	0.111	0.133	0.153	0.187	0.213
	220	0.050	0.072	0.091	0.109	0.126	0.154	0.176
	120	0.028	0.041	0.052	0.063	0.072	0.088	0.100
	195	0.050	0.072	0.091	0.109	0.126	0.154	0.176
	180	0.043	0.061	0.078	0.094	0.108	0.132	0.151
	635	0.053	0.076	0.097	0.116	0.133	0.162	0.186
	420	0.055	0.079	0.101	0.121	0.140	0.171	0.195
	335	0.058	0.083	0.106	0.127	0.146	0.179	0.204
	245	0.063	0.091	0.116	0.139	0.160	0.195	0.223
	245	0.042	0.060	0.077	0.093	0.106	0.130	0.149
	180	0.042	0.060	0.077	0.093	0.106	0.130	0.149
	305	0.026	0.038	0.048	0.058	0.066	0.081	0.093

The specified machining values are guide values.

The optimum data for the respective machining task should be determined during the test or machining.

Cutting data recommendation for CPMill replaceable milling cutters

Feed and cutting speed

Correction factor:

Length	f_z & v_c
A/B	1,0
C	0,9
D	0,7
E	0,6

CPMill-Chamfer | CPM180

CPMill-Chamfer-Twin | CPM190

MMG*		Workpiece material	Strength/hardness [N/mm ²] [HRC]	Cooling			
				MQL/Air	Dry	Coolant	
P	P1	P1.1	Structural, free-cutting, case hardened and heat-treated steels, non-alloy	< 700	✓	✓	✓
		P1.2	Structural, free-cutting, case hardened and heat-treated steels, non-alloy	< 1200	✓	✓	✓
	P2	P2.1	Nitrided, case hardened and heat-treated steels, alloy	< 900	✓	✓	✓
		P2.2	Nitrided, case hardened and heat-treated steels, alloy	< 1400	✓		✓
	P3	P3.1	Tool, bearing, spring and high-speed steels**	< 800	✓	✓	✓
		P3.2	Tool, bearing, spring and high-speed steels**	< 1000	✓		✓
		P3.3	Tool, bearing, spring and high-speed steels**	< 1500	✓		✓
	P4	P4.1	Stainless steels, ferritic and martensitic		✓		✓
	P5	P5.1	Cast steel				✓
	P6	P6.1	Stainless cast steel, ferritic and martensitic				✓
M	M1	M1.1	Stainless steels, austenitic	< 700	✓		✓
		M1.2	Stainless steels, ferritic/austenitic (duplex)	< 1000			✓
	M2	M2.1	Stainless/heat-resistant cast steel, austenitic	< 700	✓		✓
	M3	M3.1	Stainless cast steel, ferritic/austenitic (duplex)	< 1000			✓
K	K1	K1.1	Cast iron with lamellar graphite (grey cast iron), GJL	< 300	✓	✓	✓
		K2.1	Cast iron with spheroidal graphite, GJS	< 500	✓	✓	✓
		K2.2	Cast iron with spheroidal graphite, GJS	500-800	✓	✓	✓
	K3	K2.3	Cast iron with spheroidal graphite, GJS	> 800	✓	✓	✓
		K3.1	Cast iron with spheroidal graphite, GJV; malleable cast iron, GJM	< 500	✓	✓	✓
		K3.2	Cast iron with spheroidal graphite, GJV; malleable cast iron, GJM	> 500	✓	✓	✓
N	N1	N1.1	Aluminium, non-alloy and alloy < 3 % Si		✓	✓	✓
		N1.2	Aluminium, alloy ≤ 7 % Si		✓	✓	✓
		N1.3	Aluminium, alloy > 7-12 % Si		✓	✓	✓
		N1.4	Aluminium, alloy > 12 % Si		✓	✓	✓
	N2	N2.1	Copper, non-alloy and low-alloy	< 300	✓	✓	✓
		N2.2	Copper, alloy	> 300	✓	✓	✓
		N2.3	Brass, bronze, gunmetal	< 1200	✓	✓	✓

* MAPAL machining groups

** If the alloy parts Cr, Mo, Ni, V, W in total > 8%, then select the next highest MAPAL machining group.

Deburring

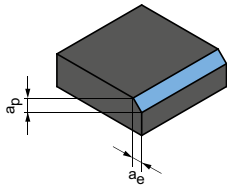

$$a_p = 0.1 \times D$$

$$a_e = 0.1 \times D$$

	v_c [m/min]	f_z [mm]				
		Diameter of milling cutter [mm]				
		8.00	10.00	12.00	16.00	20.00
	190	0.065	0.078	0.090	0.110	0.125
	155	0.061	0.073	0.084	0.102	0.117
	175	0.065	0.078	0.090	0.110	0.125
	120	0.054	0.065	0.075	0.091	0.105
	115	0.063	0.076	0.087	0.106	0.121
	105	0.060	0.072	0.082	0.101	0.115
	95	0.057	0.068	0.078	0.095	0.109
	80	0.044	0.052	0.060	0.073	0.084
	115	0.063	0.076	0.087	0.106	0.121
	80	0.030	0.036	0.042	0.051	0.059
	65	0.038	0.046	0.052	0.064	0.073
	60	0.032	0.038	0.043	0.053	0.061
	70	0.041	0.050	0.057	0.070	0.079
	65	0.033	0.039	0.045	0.055	0.063
	260	0.109	0.130	0.150	0.183	0.209
	240	0.092	0.111	0.127	0.155	0.178
	195	0.076	0.091	0.105	0.128	0.146
	110	0.044	0.052	0.060	0.073	0.084
	175	0.076	0.091	0.105	0.128	0.146
	160	0.065	0.078	0.090	0.110	0.125
	565	0.080	0.096	0.111	0.135	0.155
	375	0.085	0.101	0.116	0.142	0.162
	300	0.089	0.106	0.122	0.149	0.170
	215	0.097	0.116	0.133	0.162	0.186
	215	0.064	0.077	0.089	0.108	0.124
	160	0.064	0.077	0.089	0.108	0.124
270	0.040	0.048	0.055	0.068	0.077	

The specified machining values are guide values.

The optimum data for the respective machining task should be determined during the test or machining.

Cutting data recommendations for drill milling cutters

Feed and cutting speed

Groove milling

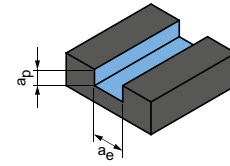

$$a_p = 1 \times D$$

$$a_e = 1 \times D$$

OptiMill-DrillMill | SCM350

MMG*	Workpiece material	Strength/hardness [N/mm ²] [HRC]	Cooling			v _c [m/min]	f _z [mm]								
			MQL/Air	Dry	Coolant		Diameter of milling cutter [mm]								
							2.00	4.00	6.00	8.00	10.00	12.00	16.00	20.00	
P	P1.1	Structural, free-cutting, case hardened and heat-treated steels, non-alloy	< 700	✓	✓	✓	120	0.008	0.014	0.021	0.027	0.032	0.037	0.045	0.051
	P1.2	Structural, free-cutting, case hardened and heat-treated steels, non-alloy	< 1200	✓	✓	✓	100	0.007	0.014	0.019	0.025	0.030	0.034	0.042	0.048
	P2.1	Nitrided, case hardened and heat-treated steels, alloy	< 900	✓	✓	✓	110	0.008	0.014	0.021	0.027	0.032	0.037	0.045	0.051
	P2.2	Nitrided, case hardened and heat-treated steels, alloy	< 1400	✓	✓	✓	75	0.006	0.012	0.017	0.022	0.027	0.031	0.037	0.043
	P3.1	Tool, bearing, spring and high-speed steels**	< 800	✓	✓	✓	70	0.007	0.014	0.020	0.026	0.031	0.035	0.043	0.049
	P3.2	Tool, bearing, spring and high-speed steels**	< 1000	✓	✓	✓	65	0.007	0.013	0.019	0.024	0.029	0.034	0.041	0.047
	P3.3	Tool, bearing, spring and high-speed steels**	< 1500	✓	✓	✓	60	0.007	0.013	0.018	0.023	0.028	0.032	0.039	0.044
P5	P5.1	Cast steel				✓	75	0.007	0.014	0.020	0.026	0.031	0.035	0.043	0.049
K	K1.1	Cast iron with lamellar graphite (grey cast iron), GJL	< 300	✓	✓	✓	130	0.013	0.024	0.035	0.044	0.053	0.061	0.075	0.085
	K2.1	Cast iron with spheroidal graphite, GJS	< 500	✓	✓	✓	120	0.011	0.021	0.029	0.038	0.045	0.052	0.063	0.072
	K2.2	Cast iron with spheroidal graphite, GJS	500-800	✓	✓	✓	95	0.009	0.017	0.024	0.031	0.037	0.043	0.052	0.060
	K2.3	Cast iron with spheroidal graphite, GJS	> 800	✓	✓	✓	55	0.005	0.010	0.014	0.018	0.021	0.024	0.030	0.034
	K3.1	Cast iron with spheroidal graphite, GJV; malleable cast iron, GJM	< 500	✓	✓	✓	85	0.009	0.017	0.024	0.031	0.037	0.043	0.052	0.060
	K3.2	Cast iron with spheroidal graphite, GJV; malleable cast iron, GJM	> 500	✓	✓	✓	80	0.008	0.014	0.021	0.027	0.032	0.037	0.045	0.051
N	N1.1	Aluminium, non-alloy and alloy < 3 % Si		✓	✓	✓	460	0.013	0.025	0.035	0.045	0.054	0.062	0.076	0.087
	N1.2	Aluminium, alloy ≤ 7 % Si		✓	✓	✓	305	0.014	0.026	0.037	0.047	0.057	0.065	0.080	0.091
	N1.3	Aluminium, alloy > 7-12 % Si		✓	✓	✓	245	0.014	0.027	0.039	0.050	0.059	0.068	0.084	0.095
	N1.4	Aluminium, alloy > 12 % Si		✓	✓	✓	175	0.015	0.030	0.042	0.054	0.065	0.075	0.091	0.104
	N2.1	Copper, non-alloy and low-alloy	< 300	✓	✓	✓	175	0.010	0.020	0.028	0.036	0.043	0.050	0.061	0.069
	N2.2	Copper, alloy	> 300	✓	✓	✓	130	0.010	0.020	0.028	0.036	0.043	0.050	0.061	0.069
	N2.3	Brass, bronze, gunmetal	< 1200	✓	✓	✓	220	0.006	0.012	0.018	0.023	0.027	0.031	0.038	0.043

* MAPAL machining groups

** If the alloy parts Cr, Mo, Ni, V, W in total > 8%, then select the next highest MAPAL machining group.

Trimming

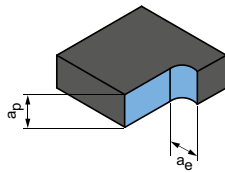

$$a_p = 1.5xD$$

$$a_e = 0.25xD$$

Trimming

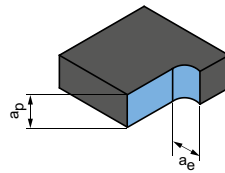

$$a_p = 1.5xD$$

$$a_e = 0.1xD$$

	v_c [m/min]	f_z [mm]								v_c [m/min]	f_z [mm]							
		Diameter of milling cutter [mm]									Diameter of milling cutter [mm]							
		2.00	4.00	6.00	8.00	10.00	12.00	16.00	20.00		2.00	4.00	6.00	8.00	10.00	12.00	16.00	20.00
	215	0.013	0.025	0.035	0.045	0.054	0.062	0.076	0.087	290	0.020	0.039	0.056	0.071	0.085	0.098	0.120	0.137
	175	0.012	0.023	0.033	0.042	0.050	0.058	0.071	0.081	235	0.019	0.036	0.052	0.067	0.080	0.092	0.112	0.128
	195	0.013	0.025	0.035	0.045	0.054	0.062	0.076	0.087	260	0.020	0.039	0.056	0.071	0.085	0.098	0.120	0.137
	135	0.011	0.020	0.029	0.038	0.045	0.052	0.063	0.072	185	0.017	0.032	0.047	0.059	0.071	0.082	0.100	0.114
	125	0.012	0.024	0.034	0.044	0.052	0.060	0.073	0.084	170	0.020	0.038	0.054	0.069	0.083	0.095	0.116	0.133
	115	0.012	0.023	0.032	0.041	0.050	0.057	0.070	0.079	155	0.019	0.036	0.051	0.065	0.078	0.090	0.110	0.126
	105	0.011	0.021	0.031	0.039	0.047	0.054	0.066	0.075	145	0.018	0.034	0.048	0.062	0.074	0.085	0.104	0.119
	130	0.012	0.024	0.034	0.044	0.052	0.060	0.073	0.084	175	0.020	0.038	0.054	0.069	0.083	0.095	0.116	0.133
	265	0.021	0.041	0.059	0.075	0.090	0.103	0.126	0.145	390	0.034	0.065	0.093	0.119	0.142	0.164	0.200	0.228
	245	0.018	0.035	0.050	0.064	0.077	0.088	0.107	0.123	355	0.029	0.055	0.079	0.101	0.121	0.139	0.170	0.194
	200	0.015	0.029	0.041	0.053	0.063	0.072	0.088	0.101	290	0.024	0.045	0.065	0.083	0.100	0.115	0.140	0.160
	110	0.009	0.016	0.024	0.030	0.036	0.041	0.051	0.058	160	0.014	0.026	0.037	0.048	0.057	0.065	0.080	0.091
	175	0.015	0.029	0.041	0.053	0.063	0.072	0.088	0.101	260	0.024	0.045	0.065	0.083	0.100	0.115	0.140	0.160
	165	0.013	0.025	0.035	0.045	0.054	0.062	0.076	0.087	245	0.020	0.039	0.056	0.071	0.085	0.098	0.120	0.137
	705	0.018	0.034	0.049	0.063	0.076	0.087	0.106	0.121	845	0.025	0.048	0.069	0.088	0.105	0.121	0.148	0.169
	470	0.019	0.036	0.052	0.066	0.079	0.091	0.112	0.128	565	0.026	0.050	0.072	0.092	0.111	0.127	0.155	0.178
	375	0.020	0.038	0.054	0.069	0.083	0.096	0.117	0.134	450	0.028	0.053	0.076	0.097	0.116	0.133	0.163	0.186
	270	0.022	0.041	0.059	0.076	0.091	0.104	0.127	0.146	325	0.030	0.057	0.083	0.106	0.126	0.145	0.177	0.203
	270	0.014	0.028	0.040	0.051	0.061	0.070	0.085	0.097	325	0.020	0.038	0.055	0.070	0.084	0.097	0.118	0.135
	205	0.014	0.028	0.040	0.051	0.061	0.070	0.085	0.097	245	0.020	0.038	0.055	0.070	0.084	0.097	0.118	0.135
	340	0.009	0.017	0.025	0.032	0.038	0.043	0.053	0.061	405	0.013	0.024	0.034	0.044	0.053	0.061	0.074	0.085

The specified machining values are guide values.
The optimum data for the respective machining task should be determined during the test or machining.



CFS REPLACEABLE HEAD HOLDERS

CFS replaceable head holders

CFS101 | CFS201 replaceable head holder _____ 218

Accessories

Mounting aids _____ 219

Technical appendix

Handling notes CPMill replaceable milling cutters _____ 404

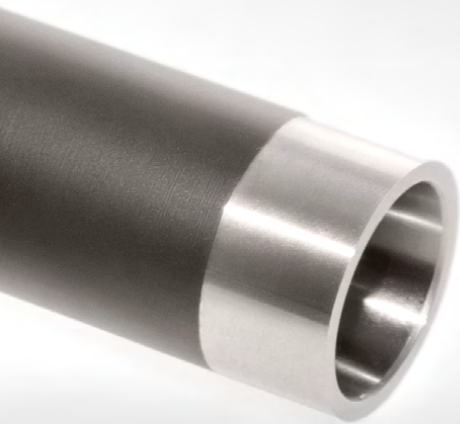

CFS replaceable head holders

Conical and cylindrical design, with internal cooling
CFS101 | CFS201

Length category:



Conical design

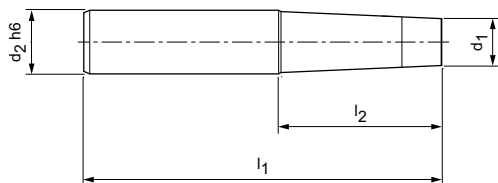

Cylindrical design

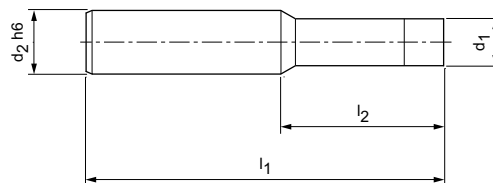

Conical design made of steel, CFS201 | Preferred series in stock

CFS size	Dimensions				Length category	Specification	Order no.
	d ₁	d ₂ h6	l ₁	l ₂			
6	7,8	10	60	20	A	CFS201N-06-020-ZYL-HA10-S	30393776
8	9,8	16	70	30	A	CFS201N-08-030-ZYL-HA16-S	30393787
8	9,8	16	90	40	B	CFS201N-08-040-ZYL-HA16-S	30393788
10	11,8	16	70	30	A	CFS201N-10-030-ZYL-HA16-S	30393798
10	11,8	16	90	42	B	CFS201N-10-042-ZYL-HA16-S	30393799
12	15,8	20	80	30	A	CFS201N-12-030-ZYL-HA20-S	30393963
12	15,8	20	105	55	B	CFS201N-12-055-ZYL-HA20-S	30393964
16	19,8	25	90	40	B	CFS201N-16-040-ZYL-HA25-S	30393976

Conical design made of carbide, CFS201 | Preferred series in stock

6	7,8	10	110	70	C	CFS201N-06-070-ZYL-HA10-H	30393779
8	9,8	16	110	60	C	CFS201N-08-060-ZYL-HA16-H	30393790
10	11,8	20	110	60	C	CFS201N-10-060-ZYL-HA20-H	30393801
10	11,8	20	150	100	D	CFS201N-10-100-ZYL-HA20-H	30393802
12	15,8	20	130	80	C	CFS201N-12-080-ZYL-HA20-H	30393966
12	15,8	20	150	100	D	CFS201N-12-100-ZYL-HA20-H	30393967
16	19,8	25	150	94	D	CFS201N-16-094-ZYL-HA25-H	30393979

Cylindrical design made of steel, CFS101 | Preferred series in stock

6	7,8	10	85	45	B	CFS101N-06-045-ZYL-HA10-S	30393771
8	9,8	12	90	45	B	CFS101N-08-045-ZYL-HA12-S	30393782
10	11,8	16	90	42	B	CFS101N-10-042-ZYL-HA16-S	30393793
12	15,8	16	105	57	B	CFS101N-12-057-ZYL-HA16-S	30393956
16	19,8	25	120	64	B	CFS101N-16-064-ZYL-HA25-S	30393969

Accessories – mounting aids

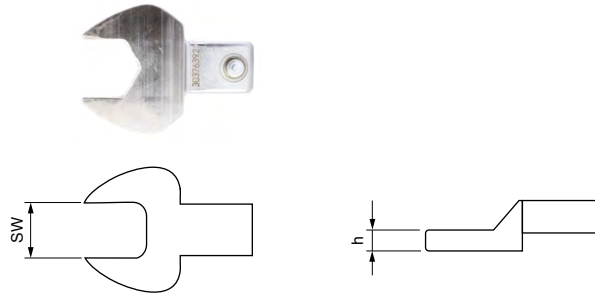
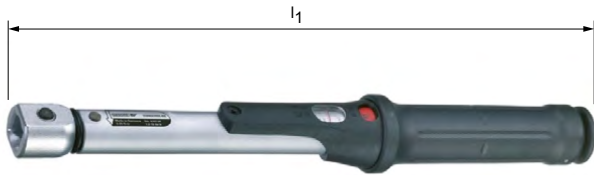

Torque wrench

Attachment shank	Torque [Nm]	Total length l_1	Order no.
9x12	2 - 25	274	30386735
14x18	20 - 200	470,5	30386736

Open-ended spanner attachments for torque wrenches

SW	Dimensions		Order no.
	h	Attachment shank	
SW 6	2,3	9 x 12	30376387
SW 8	2,8	9 x 12	30376388
SW 10	3,8	9 x 12	30376390
SW 11	3,8	9 x 12	30672376
SW 13	3,8	9 x 12	30376392
SW 15	3,8	9 x 12	30376393
SW 16	4,8	9 x 12	30376394
SW 18	4,8	9 x 12	30673296
SW 21	4,8	14 x 18	30376395

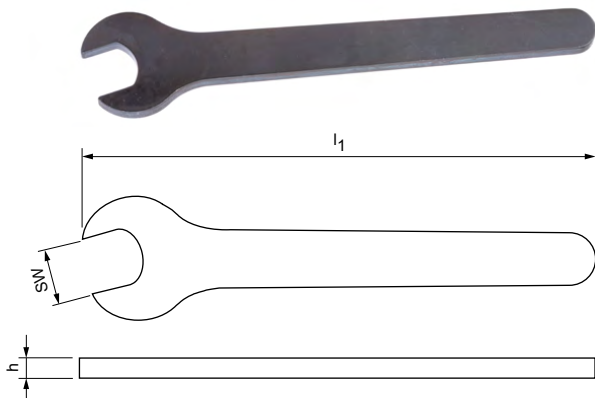

Assembly tool

Connection size CFS	Dimensions			Order no.
	SW	l_1	h	
6	SW 6	75	2,3	30352660
8	SW 8	92	2,8	30352661
10	SW 10	100	3,8	30352662
12	SW 13	135	3,8	30352663
16	SW 16	145	4,8	30352667
20	SW 21	195	4,8	30352668

MILLING CUTTERS WITH REPLACEABLE INSERTS

Milling cutters with indexable inserts and PCD milling inserts.





PRODUCT OVERVIEW

Milling cutters with replaceable inserts



MAPAL offers a standard range of milling cutters with radial (NeoMill) and tangential indexable inserts (TGMill) under the label milling cutters with replaceable inserts. For machining non-ferrous metals, the milling head systems are available with the NeoMill-Diamond-Power and -Eco PCD milling inserts as well as milling cutters with brazed PCD cutting edges (FaceMill-Diamond).

The NeoMill range with its face, corner, slot, shell end and high-feed milling cutters stands for maximum productivity and economic efficiency, especially in series production. The development was based on many years of experience with custom tools, which the industry uses to produce large quantities very efficiently with consistent quality.

The TGMill milling cutters are characterised by tangentially embedded cutting edges and achieve excellent machining results and long tool lives due to reduced cutting forces. Depending on requirements, milling cutters with narrow and wide spacing can be selected for face milling, corner milling, end milling, helical milling and disc milling cutters.

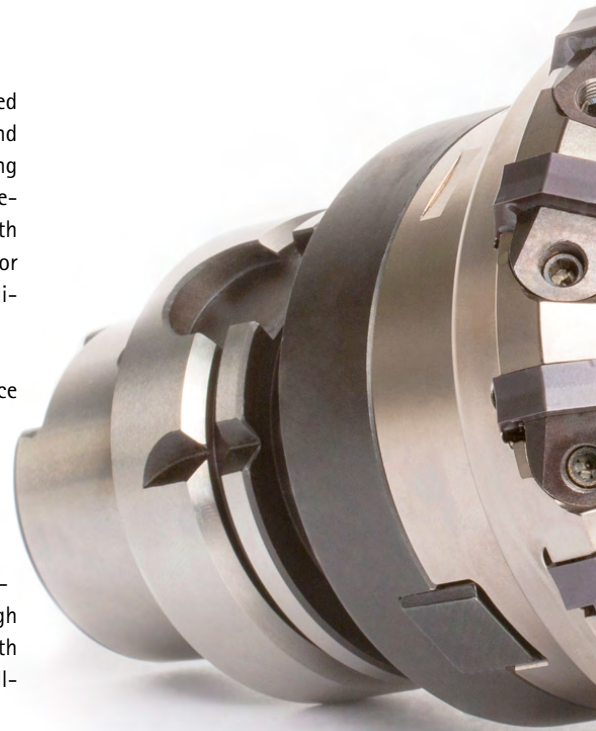
High stock removal rates, defined surface roughness or special requirements for the flatness of the part – the Power and Eco milling head systems are designed for high-performance machining of non-ferrous metals. A µm-accurate adjustment ensures perfect surface finishes for all series. Considerable cost savings can be achieved through reliable, fast and precise reconditioning with the MAPAL Maintenance Service for face milling heads.



Face milling cutter	Shoulder milling cutter	High-feed milling cutter	
			
<p>Face milling with indexable inserts</p> <p>Roughing and semi-machining face surfaces.</p> <p>NeoMill-Face:</p> <ul style="list-style-type: none"> - Milling cutters available with 8- and 16-edge radial indexable inserts - Cutting depths from up to 5 mm <p>TGMill-Face45:</p> <ul style="list-style-type: none"> - 4+4-edge tangential indexable inserts available - Cutting depths from up to 8 mm <p>∅ area: 63.00 - 400.00 mm</p> <p>P M K</p>	<p>Face milling with PCD</p> <p>Ideal for producing the top-quality surface finishes on parts made of aluminium.</p> <p>NeoMill-Diamond System Power:</p> <ul style="list-style-type: none"> - All-rounder for roughing and finishing - Robust adjusting screw - Cutting depths from up to 5 mm <p>NeoMill-Diamond System Eco:</p> <ul style="list-style-type: none"> - Designed for finishing operations with high-quality surface finishes - Sensitive wedge adjustment - Cutting depths from up to 3 mm <p>FaceMill-Diamond:</p> <ul style="list-style-type: none"> - Milling cutter with brazed cutting edges for cutting depths of up to 8 mm <p>∅ area: 32.00 - 500.00 mm</p> <p>N C</p>	<p>Ideal for milling 90° shoulder surfaces</p> <p>NeoMill-Corner:</p> <ul style="list-style-type: none"> - Milling cutter available with double-, four- and eight-edge radial indexable inserts - Positive basic shape for parts susceptible to vibrations - Cutting depths from up to 17 mm <p>TGMill-Corner:</p> <ul style="list-style-type: none"> - Milling cutters available with double- and four-edge tangential indexable inserts - Cutting depths from up to 7 mm <p>∅ area: 10.00 - 200.00 mm</p> <p>P M K N</p>	<p>Milling at high feed rates</p> <p>NeoMill-HiFeed90:</p> <ul style="list-style-type: none"> - Universal tool system to ensure maximum productivity - Tool body with indexable inserts for high-feed and shoulder milling - Maximum rate of removal due to very high feed rates and large cutting depths - Tool and storage costs are reduced - Double- and four-edge radial indexable insert available - Available as arbor and end milling cutter <p>∅ area: 10.00 - 200.00 mm</p> <p>P M K H N</p>
<p>Page 249</p>	<p>Page 249</p>	<p>Page 291</p>	<p>Page 309</p>



Copy milling cutter

Shell end face milling cutter

Helix milling cutters

Disc milling cutter

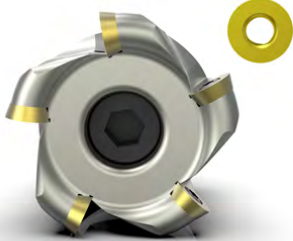

Roughing and pre-finishing of 3D contours

NeoMill-ISO-360:

- Perfect for roughing and pre-finishing
- Cutting materials and cutting edge designs are available for soft machining as well as hard/finish machining
- High-precision contours due to the indexable inserts being installed in a neutral position
- Soft cutting behaviour for low vibration machining
- Chip discharge protection
- Available as arbor and end milling cutter

Ø area: 15.00 - 160.00 mm

P M K H

Shell end face milling

Ideal for deep shoulder milling and trimming with high cutting depths of up to 75 mm.

NeoMill-Shell:

- Milling cutters with double- or four-edge radial indexable inserts
- Also suitable for heavy machining and full slot milling

TGMill-Shell:

- Milling cutters with double- or four-edge tangential indexable insert

Ø area: 25.00 - 105.00 mm

P M K N

Helix milling

For roughing, large bore diameter (> 150 mm).

TGMill-Helical:

- Cutting depths from up to 35 mm
- Helical plunging and ramping possible
- Optional with vibration damper
- Ideal for machining centres
- Available as double- and four-edge tangential indexable inserts
- Available as milling cutter and with HSK-A (hollow shank taper form A) connection

Ø area: 80.00 - 160.00 mm

P M K N

Milling of deep shoulder surfaces or slots

TGMill-Disc:

- Can be used as a gang milling cutter or milling shaft
- Cutting depths from up to 17 mm
- Ideal for machine tools with extending sleeve
- Can be adjusted axially for finishing
- Available as double- and four-edge tangential indexable inserts
- Contact angle of 90°









Ø area: 100.00 - 200.00 mm

P M K N

SELECTING A MILLING CUTTER

Step-by-step guide to selecting the right milling cutter

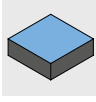
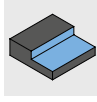
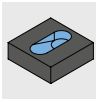
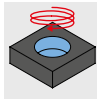
Say you're looking for a milling cutter with indexable inserts for shoulder milling stainless steel with a diameter of 125 mm in unfavourable machining conditions? This selection guide explains how to choose the right milling cutter step by step.

1	Type of milling cutter	Select the type of milling cutter you need.	➤		Face milling cutter		Shoulder milling cutter
2	Material suitability	Select your workpiece according to the MAPAL machining groups (MMG). You'll find the MMG chart on the fold-out page at the end of the catalogue.	➤		Steel		Stainless steel
3	Manufacturing processes	Select your manufacturing process.	➤		Roughing		Medium machining
4	Process conditions	Assess your process conditions.	➤		Good: – Stable conditions – Low cutting width		
5	Application	Select your preferred application.	➤		Face milling		Shoulder milling
					Ramps		Helix milling
6	Technical design / Geometric features	Check that the geometric features meet your requirements.	➤		Max. cutting depth		Diameter range
7	Tool body	Select the milling cutter you need. If there are several possible selections, select the milling cutter that is marked as 1st choice (★) for material suitability.	➤		If designs with different spacing are available, please note the information on the relevant product pages.		
8	Indexable insert / Milling cartridge	Select the indexable insert or milling cartridge you need. For the selection of the correct cutting material, pay attention to the cutting material overview on page 234. The name of the indexable insert is supplemented with the selected cutting edge design and the cutting material type. Example: RDKW1003M0N-PMU-HP635	➤		Select the indexable insert or milling cartridge you need.		



High-feed milling cutter



Shell end face milling cutter



Copy milling cutter



Helix milling cutters



Disc milling cutter



Cast iron

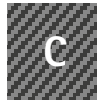

Composite materials



Non-ferrous metals and plastics



Super alloy and titanium



Finishing



Unfavourable:

- Ratio $a_e / D > 0.6$
- High stock removal
- Part/clamping fixture/machine susceptible to vibration

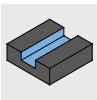

Groove milling

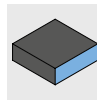

Trimming

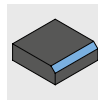

Chamfering and deburring

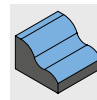

Profile milling

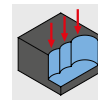

Plunge milling / Groove milling



High-feed milling



Pocket milling

Contact angle

Number of cutting edges

Coolant supply

Technology (radial/tangential)

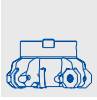

Face milling cutter

Face milling cutter with indexable inserts

Material suitability								Manufacturing processes			Process conditions		Application											
P	M	K	N	C	S	H																		
★	☐						■	■		■	■	■												
■	★*	★					■	■		■	☐	■												
■		■					■	☐		■	☐	■												

Face milling cutter with PCD milling inserts

Material suitability								Manufacturing processes			Process conditions		Application											
P	M	K	N	C	S	H																		
			■	☐			☐	■	■	■	■	■	■											
			■	☐			★	★	■	■	■	■	■											
			■	☐				☐	■	■	■	■	■											
			■	☐					★	■	■	■	■											
			■	☐					■	■	■	■	■											
			■	☐				☐	■	■	■	■	■											
			■	☐			☐	■	■	■	■	■	■											

★ 1. choice ■ highly suitable ☐ suitable in some situations

Step 1:
Type of milling cutter



Step 2:
Material suitability



Step 3:
Manufacturing processes



Step 4:
Process conditions



Step 5:
Application

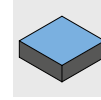

Step 6:
Design



	Technical design						Tool body			Indexable insert		
	\varnothing [mm]	a_p max. [mm]	Cutting edges	Contact angle	Technology		Product name	Design	Page	Product name		Page
	63 - 200	5	8	45°	Radial	✓**	NeoMill-8-Face		250	OFMT07		251
	63 - 200	4	16	45°	Radial	✓**	NeoMill-16-Face		252	ONKU07		253
	80 - 200	8	4	45°	Tangential	✓	TGMill-4-Face45		254	LTHU15		255

	Technical design						Tool body			Milling cartridge			
	\varnothing [mm]	a_p max. [mm]	Chip removal	Coolant supply		Can be reground	Product name	Design	Page	Product name		Page	
				Cutting edge	Central								
	50 - 250	5	Replaceable chip deflector			✓	✓	NeoMill-Diamond-Power		262	PMC with face milling insert		265
	50 - 400	5	Integrated chip deflector	✓			✓	NeoMill-Diamond-PowerBlue		267	PBC with face milling insert		269
	50 - 250	3	Integrated chip deflector			✓		NeoMill-Diamond-Eco		272	EMC with face milling insert		275
	32 - 400	2	Integrated chip deflector	✓				NeoMill-Diamond-EcoBlue		276	EBC with face milling insert		279
	50 - 200	1	Integrated chip deflector	✓				NeoMill-Diamond-RapidBlue		280	RBC with face milling insert		281
	63 - 160	3				✓		NeoMill-Diamond-FlyCutter		282	FMC with face milling insert		283
	40 - 125	10		✓			✓	FaceMill-Diamond		284	brazed		

* in the case of heat-resistant cast steel

** up to dia. 125 mm



Shoulder milling cutter

Shoulder milling cutter with indexable inserts

Material suitability								Manufacturing processes			Process conditions		Application										
P	M	K	N	C	S	H																	
■	■						■	■		■	■	■	■				■	■	■				
■	■	■					■	■		■	■	■	■				■	■	■				
■	■	■	■				■	■		■	■	■	■				■	■	■				
■	★	■					■	■		■	■	■	■										
★	■						■	■		■	■	■	■				■						
■	■	★					■	■		■	■	■	■										
			★				■	■		■	■	■	■										
■	■	■					■	■		■	■	■	■										

Shoulder milling cutter with PCD milling cartridges

Material suitability								Manufacturing processes			Process conditions		Application										
P	M	K	N	C	S	H																	
			★	■			■	■	■	■	■	■	■										

★ 1. choice ■ highly suitable ■ suitable in some situations

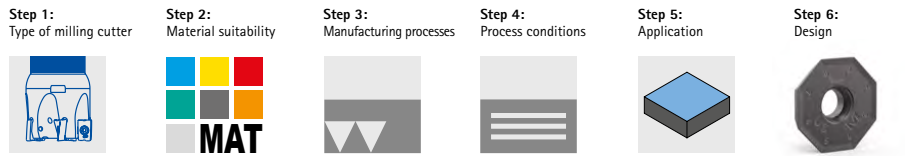

	Technical design						Tool body			Indexable insert		
	\varnothing [mm]	a_p max. [mm]	Cutting edges	Contact angle	Technology		Product name	Design	Page	Product name		Page
	10 - 50	5,2	2	90°	Radial	✓	NeoMill-2-HiFeed90		310	LPMX06		318
	20 - 63	11	2	90°	Radial	✓*	NeoMill-2-Corner		292	AOKT12		293
	25 - 160	17	2	90°	Radial	✓	NeoMill-2-HiFeed90		314	LD_X18		318
	25 - 100	10	4	90°	Radial	✓*	NeoMill-4-Corner		294	ANMU12		295
	40 - 160	8	4	90°	Radial	✓*	NeoMill-4S-Corner		296	SDKT10		297
	50 - 160	8	8	90°	Radial	✓*	NeoMill-8-Corner		298	SNMU12		299
	63 - 200	7	2	90°	Tangential	✓	TGMill-2-Corner		300	CTHD09		301
	63 - 200	7	4	90°	Tangential	✓	TGMill-4-Corner		302	CT_Q09		304

	Technical design						Tool body			Milling cartridge		
	\varnothing [mm]	a_p max. [mm]	Chip removal	Coolant supply		Can be reground	Product name	Design	Page	Product name		Page
	32 - 400	1 - 10**	**	Cutting edge	Central		Milling cutter with PCD milling cartridges		226	Milling cartridge with corner milling blade		226
				✓**	✓**	✓**						

* in the case of heat-resistant cast steel
 ** up to dia. 125 mm



High-feed milling cutter

Material suitability								Manufacturing processes			Process conditions		Application										
P	M	K	N	C	S	H																	
★	■					■	■			■	■	■	■	■				■	■	■	■	■	
★	■	★	■			■	■	■		■	■	■	■	■				■	■	■	■	■	
★	■					■	■	■		■	■	■	■	■				■	■	■	■	■	
★	■	★	■			■	■	■		■	■	■	■	■				■	■	■	■	■	
★	■	★	■			■	■	■		■	■	■	■	■				■	■	■	■	■	
★	■	★				■	■	■		■	■	■	■	■				■	■	■	■	■	

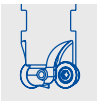

Copy milling cutter

Material suitability								Manufacturing processes			Process conditions		Application										
P	M	K	N	C	S	H																	
■	■	■				■	■	■		■	■	■			■	■	■	■	■	■	■	■	■
■	■	■				■	■	■		■	■	■			■	■	■	■	■	■	■	■	■
★	★	★				■	■	■		■	■	■			■	■	■	■	■	■	■	■	■
■	■	■				■	■	■		■	■	■			■	■	■	■	■	■	■	■	■

★ 1. choice ■ highly suitable ■ suitable in some situations

Step 1:
Type of milling cutter



Step 2:
Material suitability



Step 3:
Manufacturing processes



Step 4:
Process conditions



Step 5:
Application

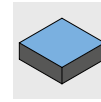

Step 6:
Design



	Technical design						Tool body			Indexable insert		
	\emptyset [mm]	a_p max. [mm]	Cutting edges	Contact angle	Technology		Product name	Design	Page	Product name		Page
	10 - 50	0,7	2	High feed	Radial	✓	NeoMill-2-HiFeed90		310	LPMX06		316
	16 - 80	1,4	2	High feed	Radial	✓	NeoMill-2-HiFeed90		312	LD_X10		316
	16 - 35	1	4	High feed	Radial	✓	NeoMill-4-HiFeed90		320	SD__06		326
	25 - 80	1,5	4	High feed	Radial	✓	NeoMill-4-HiFeed90		322	SD__10		326
	50 - 125	2,4	4	High feed	Radial	✓	NeoMill-4-HiFeed90		324	SD__14		326
	80 - 200	3,5	4	High feed	Radial	✓	NeoMill-4-HiFeed90		325	SD__18		326

	Technical design						Tool body			Indexable insert / Milling cartridge		
	\emptyset [mm]	a_p max. [mm]	Cutting edges	Contact angle	Technology		Product name	Design	Page	Product name		Page
	15 - 16	3,5	*	0°	Radial	✓	NeoMill-ISO-360		334	RD__07		338
	20 - 52	5	*	0°	Radial	✓	NeoMill-ISO-360		335	RD__10		338
	42 - 80	6	*	0°	Radial	✓	NeoMill-ISO-360		336	RD__12		338
	50 - 160	8	*	0°	Radial	✓	NeoMill-ISO-360		337	RD__16		338



Shell end face milling cutter

Material suitability								Manufacturing processes			Process conditions		Application										
P	M	K	N	C	S	H																	
■	■	★					■	■		■	■		■	■	■								
■	■	■					■	■		■	■		■	■	■								
★	★	■					■	■		■	■		■	■	■								
			■				■	■		■	■		■	■	■								



Helix milling cutters

Material suitability								Manufacturing processes			Process conditions		Application										
P	M	K	N	C	S	H																	
★	★	★					■	■		■	■		■					■	■				
			★				■	■		■	■		■					■	■				



Disc milling cutter

Material suitability								Manufacturing processes			Process conditions		Application											
P	M	K	N	C	S	H																		
★	★	★					■	■	■	■	■		■	■										
			★				■	■	■	■	■		■	■										

★ 1. choice ■ highly suitable ■ suitable in some situations

Step 1:
Type of milling cutter



Step 2:
Material suitability



Step 3:
Manufacturing processes



Step 4:
Process conditions



Step 5:
Application

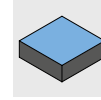

Step 6:
Design



	Technical design						Tool body			Indexable insert		
	\emptyset [mm]	a_p max. [mm]	Cutting edges	Contact angle	Technology		Product name	Design	Page	Product name		Page
	32 - 63	62	4	90°	Radial	✓	NeoMill-4-Shell		346	ANMU12		347
	25 - 40	62	2	90°	Radial	✓	NeoMill-2-Shell		344	AOKT12		345
	63 - 100	75	4	90°	Tangential	✓	TGMill-4-Shell		350	CTHQ09		352
	63 - 100	75	2	90°	Tangential	✓	TGMill-2-Shell		348	CTHD09		349

	Technical design						Tool body			Indexable insert		
	\emptyset [mm]	a_p max. [mm]	Cutting edges	Contact angle	Technology		Product name	Design	Page	Product name		Page
	80 - 125	35	4	90°	Tangential	✓	TGMill-4-Helical		358	CTHQ09		359
	80 - 125	35	2	90°	Tangential	✓	TGMill-2-Helical		360	CTHD09		362

	Technical design						Tool body			Indexable insert		
	\emptyset [mm]	a_p max. [mm]	Cutting edges	Contact angle	Technology		Product name	Design	Page	Product name		Page
	100 - 200	17	4	90°	Tangential		TGMill-4-Disc		368	CTHQ09		369
	100 - 200	17	2	90°	Tangential		TGMill-2-Disc		370	CTHD09		372

* depending on a_p max.

Cutting material overview: Selection of the correct cutting material

The cutting materials from MAPAL cover a wide spectrum of wear resistance and ductility. The designation of the cutting material indicates the level of ductility; the ductility increases as the number increases.

PVD-coated cutting materials (HP...) are the first choice for milling K, P and M workpiece materials. These cutting materials have the longest tool life. If high cutting speeds are to be realised, CVD-coated cutting materials (HC...) should be selected.

For non-ferrous workpiece materials, uncoated and coated carbide grades (HU.../HP...) are the first choice. From a silicon content of $\geq 12\%$, PCD (PU...) is recommended due to increasing abrasiveness. With PCD, maximum tool life is achievable, which is why this cutting material is particularly suitable for large series.

Example: HP980 is more ductile than HP965 (the more ductile the cutting material, the less resistant it is to wear).

1. Choose your workpiece material using the MMGs (MAPAL Machining Groups).
2. Depending on the tool type, select the material type below the desired workpiece material in the corresponding "Cutting material overview [...]" table.
3. Depending on the general conditions (see table "General conditions"), a wear-resistant or more ductile cutting material is to be selected.
4. If general conditions in the direction of the black arrow predominate and breakages cannot be prevented despite a ductile CVD grade, you should change to PVD-coated cutting materials.

General conditions

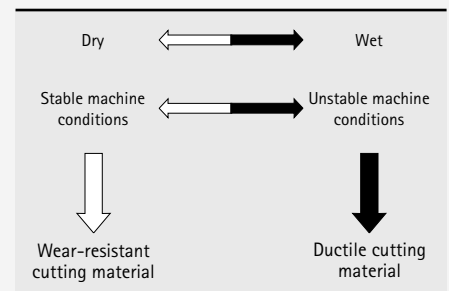

Cutting material overview | Face, corner, end face, helix and disc milling cutters

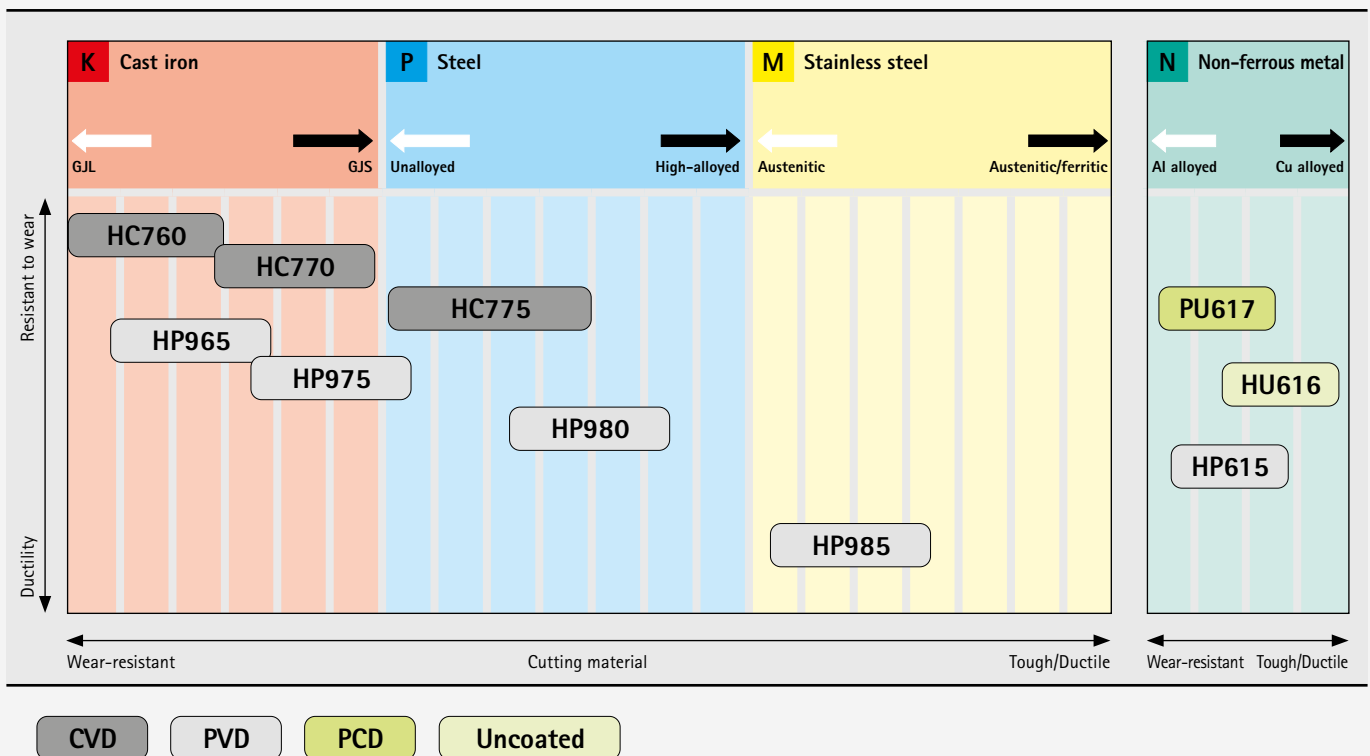

Cutting material overview | High-feed and copy milling cutters from the Die & Mould sector

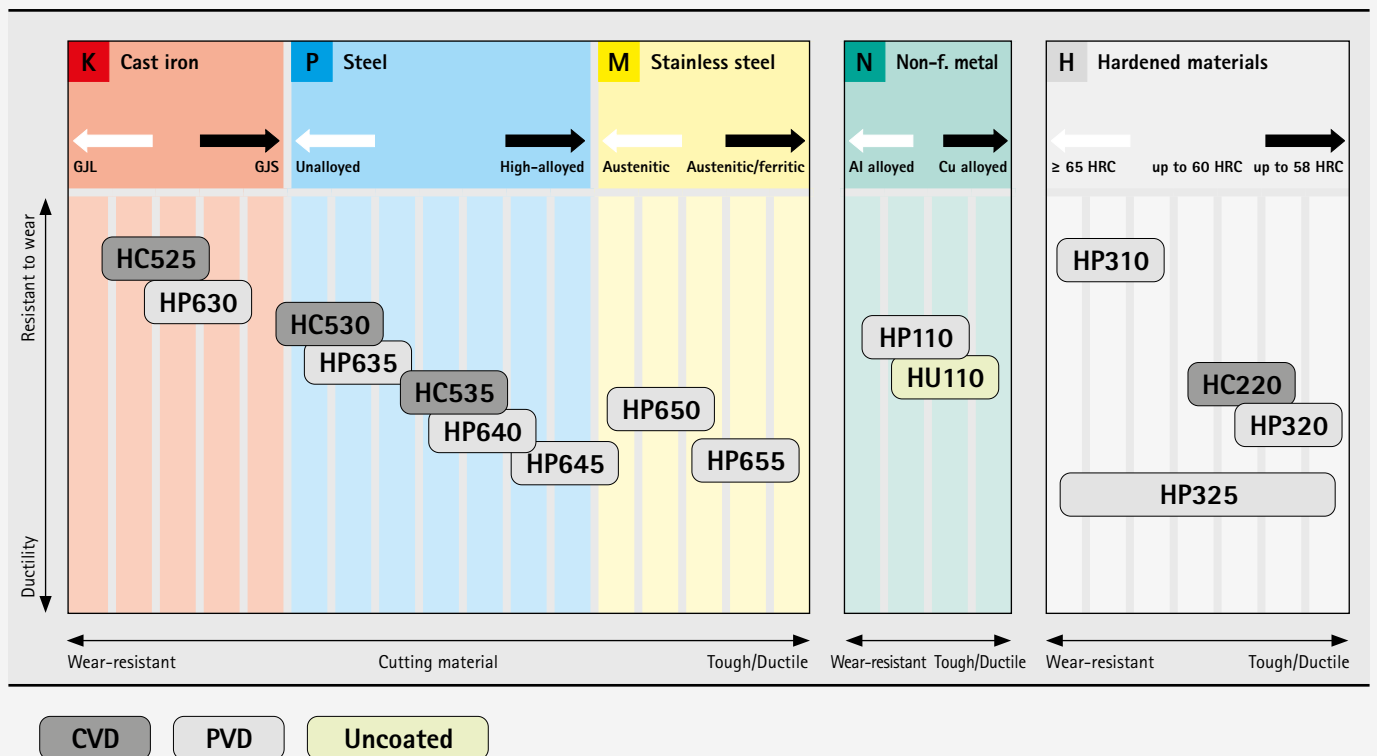

Cutting Material Overview: Types and type description

Milling cutters with indexable inserts

Cutting material	Name of cutting material	Coating composition	Colour of coating	Field of application	Recommended application
Carbide PVD-coated	HP110	AlTiN	dark grey	●	TiAlN-coated carbide for machining aluminium materials and other non-ferrous metals. Due to the very thin layer, the cutting material is also well suited for finishing stainless steels and grey cast iron.
	HP310	TiSiN	reddish brown	●	Finest grain-carbide grade with high wear resistance and temperature stable PVD coating. Suitable for the finishing of steel materials in the area of the highest cutting speeds.
	HP320	AlTiN	light grey	●	Universal ultra-fine grain-carbide grade, which is highly resistant to wear and has good breakage resistance and edge stability. Suitable for the machining of hard steel materials up to max. 60 HRC thanks to the temperature resistant PVD coating.
	HP325	AlTiN	light grey	✚	Finest grain-carbide grade with a balanced ratio between ductility and resistance to wear. Wide field of applications for steel materials due to the stress-optimised PVD coating.
	HP615	TiB2	silver-grey	●	Fine grain carbide with a partially reduced PVD coating for machining adhesive materials. First choice for increasing tool life compared to uncoated cutting edges when machining aluminium alloys with 7-12% Si.
	HP630	AlTiN	dark grey	●	Ductile carbide grade with an AlTiN coating. Suitable for the machining of cast iron materials. Also suitable for finishing steel materials and cold work steels with a hardness of more than 54 HRC.
	HP635	AlTiN-TiN	gold	●	Carbide grade with PVD coating. Suitable for milling unalloyed, low-alloyed, high-alloyed and stainless steels. Particularly suitable for high cutting speeds in both dry and wet machining under stable conditions.
	HP640	AlTiN-TiN	gold	●	Universal carbide grade with high ductility and an AlTiN-TiN coating. Suitable for the machining of steel materials. Particularly suitable for dry milling at low to medium cutting speeds under difficult conditions.
	HP645	AlTiN-TiN	gold	✚	Ductile carbide grade with a PVD coating. Suitable in the event that the cutting of steel materials such as tool steels, heat-treated steel, case hardening steels and austenitic stainless materials is sharply interrupted.
	HP650	AlTiN	dark grey	●	Finest grain-carbide grade with a wear-resistant AlTiN coating. Suitable for the machining of stainless and austenitic stainless materials. Suitable for both the wet and dry machining.
	HP655	AlTiN	dark grey	●	Fine grain-carbide grade with extreme ductility. A thin, smooth PVD coating is ideal for the milling of austenitic stainless steels and duplex group workpiece materials at low to medium cutting speeds.
	HP965	AlTiN	black anthracite	●	PVD-coated fine grain carbide grade for medium machining and for roughing GJL, GJV and GJS. Suitable for the wet or dry machining at medium to high cutting speeds.
	HP975	AlTiN	black anthracite	✚	Ductile carbide grade with PVD thick layer for challenging milling in cast materials. Particularly suitable for GJS cast iron or ADI workpiece material and low-alloy steel in unstable conditions.
	HP980	AlTiN	black anthracite	✚	Ductile, PVD coated carbide grade for the general machining of steel and alloyed steel. Increased wear resistance with good impact resistance at the same time.
	HP985	AlTiN	black anthracite	✚	PVD-coated carbide grade for milling stainless and heat-resistant steels. Combination of good ductility and heat-resistant coating.

Cutting Material Overview: Types and type description

Milling cutters with indexable inserts

Cutting material	Name of cutting material	Coating composition	Colour of coating	Field of application	Recommended application
Carbide CVD-coated	HC220	AlTiN	black anthracite	●	Wear-resistant finest grain-carbide grade for a wide range of applications. Suitable for steel materials under stable conditions. New CVD coating with high temperature hardness, which is resistant to wear and tear.
	HC525	AlTiN	black anthracite	●	Optimised carbide substrate with an extremely hard and wear-resistant CVD multilayer coating. Ideally suited for dry machining of GJL, GJS, malleable cast iron and alloyed cast iron.
	HC530	AlTiN	black anthracite	●	Harder alternative to HP635 with a CVD coating that is highly resistant to abrasive wear and tear. Excellent for the face milling of steel materials with increased cutting speed under stable conditions.
	HC535	AlTiN	black anthracite	●	This ductile carbide grade with a CVD coating for dry machining at high cutting speeds. Particularly suitable for face milling for a wide range of steel materials.
	HC760	TiCN+Al ₂ O ₃	black	●	Fine grain carbide with high resistance to wear and a multi-layer CVD coating with Al ₂ O ₃ top coating for medium machining to roughing of GJL at high cutting speeds.
	HC770	TiCN+Al ₂ O ₃	black	●	Fine grain carbide with high wear resistance and a multi-layer CVD coating with Al ₂ O ₃ top coating. Wide field of applications for medium machining to roughing from GJS to unalloyed and low-alloy steels.
	HC775	TiCN+Al ₂ O ₃	black	✚	Fine grain carbide with a balanced relationship between wear resistance and ductility and a multi-layer CVD coating with Al ₂ O ₃ top coating for machining at higher cutting speeds. For unstable conditions and workpiece material with increased tensile strength.
Carbide Uncoated	HU110	-	-	●	Uncoated carbide grade for the machining of aluminium and other non-ferrous metals.
	HU616	-	-	●	Fine grain carbide with very smooth surface for the general machining of aluminium wrought alloys and aluminium cast alloys with Si contents < 3%.
PCD	PU617	-	-	●	PCD grade with medium particle size for roughing to semi-machining in non-ferrous metals and for machining very abrasive materials.

Milling cutter with PCD milling cartridges and PCD end milling cutter

Cutting material	Name of cutting material	Coating composition	Colour of coating	Field of application	Recommended application
PCD	PU611	-	-	●	Universal PCD grade with medium particle size. First choice for milling non-ferrous metals with a low proportion of abrasive fillers (e.g. aluminium with Si <=12%)
	PU622	-	-	●	PCD grade with fine particle size. Optimal choice for machining non-ferrous metals with increased surface requirements and low-alloy AlSi compounds (e.g. aluminium with Si <5%).

Product ID codes

Milling cutters with replaceable inserts

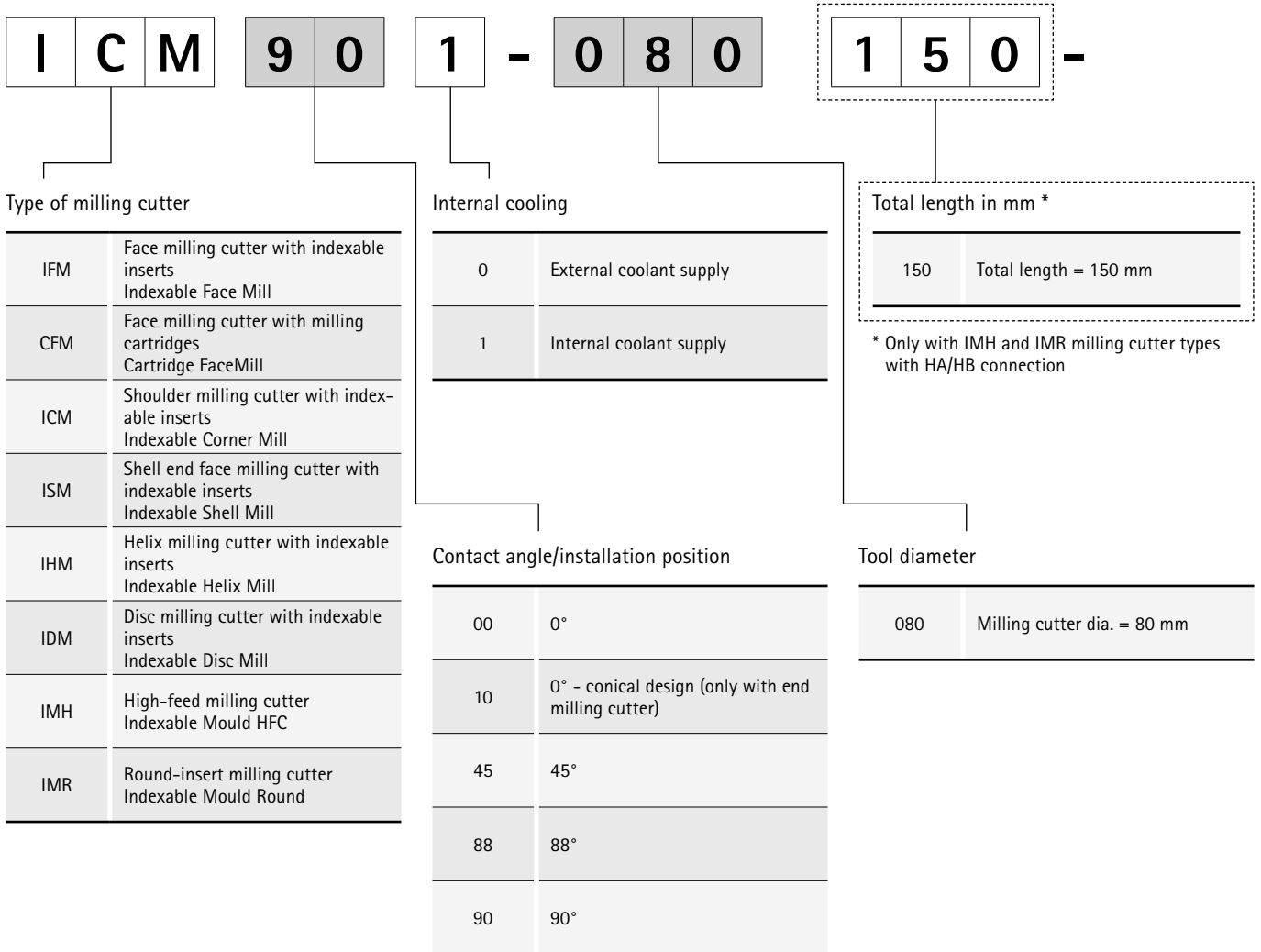

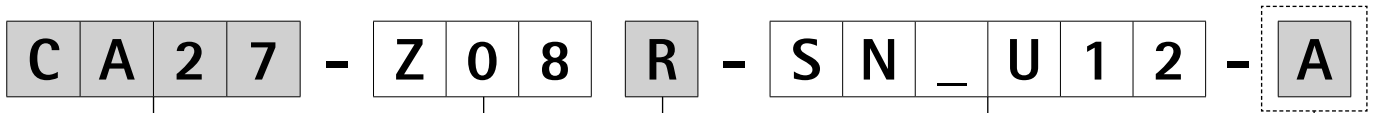

Connection (examples)

HA32	Cylindrical shank dia. = 32 mm Shape HA
HB32	Cylindrical shank dia. = 32 mm Shape HB
CA16	Milling cutter arbor dia. = 16 mm
CA22	Milling cutter arbor dia. = 22 mm
CA27	Milling cutter arbor dia. = 27 mm
CA32	Milling cutter arbor dia. = 32 mm
CA40	Milling cutter arbor dia. = 40 mm
CA60	Milling cutter arbor dia. = 60 mm
A063	HSK-A63
A080	HSK-A80
A100	HSK-A100
M045	Thread M4.5
M010	Thread M10
M012	Thread M12
M016	Thread M16
S050	SK50 Form AD/AF ISO 7388-1

Rotational direction

R	Right
L	Left
R1	Right Disc milling cutter (left-side cutting)
R2	Right Disc milling cutter (right-side cutting)
R3	Right Disc milling cutter (both sides, 3-sided cutting)

Effective (eff.) number of cutting edges (example)

Z05	Number of teeth eff. = 5
Z10	Number of teeth eff. = 10
Z9+3	Number of teeth eff. = 12 of which three are adjustable inserts
Z12+4	Number of teeth eff. = 16 of which four are adjustable inserts
Z6+6	Disc milling cutter Number of teeth eff. = 6 (both sides, 3-sided cutting)
Z7+7	Face milling cutter LT_U Number of teeth eff. = 14 (alternating installation)

Workpiece material tool body*

A	Tool body made of aluminium
S	Tool body made of steel

* Only with CFM milling cutter type

Indexable insert/milling cartridge

2nd letter "T"	CT... Tangential LT... Tangential
2nd letter "D, F, N, O, P"	AN... Radial AO... Radial OF... Radial ON... Radial SD... Radial SN... Radial LP... Radial LD... Radial RD... Radial
3rd letter "C"	PMC... Power EMC... Eco FMC... FlyCutter EBC... EcoBlue PBC... PowerBlue

Product ID codes

Radial indexable inserts

S

N

M

U

1

2

0

5

0

8

Insert form

S (90°)

O (135°)

A (85°)

Tolerance

	d [mm]	m [mm]	s [mm]
M	from ±0.05 to ±0.15*	from ±0.08 to ±0.20 *	from ±0.05 to ±0.13*
K	from ±0.05 to ±0.15*	±0.013	±0.013
H	±0.013	±0.013	±0.025

* Tolerance depends on the insert size

Insert size

Insert size			
d [mm]	S	O	A
7.5	-	-	12
7.5	-	-	12
10	10	-	-
11.5	12	-	-
19	-	07	-
20	-	07	-

Insert thickness

Identification number	s [mm]
T3	3.97
04	4.76
05	5.56

Clearance angle

N	0°
D	15°
O	Custom
F	25°

Insert type

	T
	U
Custom	Custom
X	X

Corner radius

Identification number	r [mm]
08	0.8
12	1.2

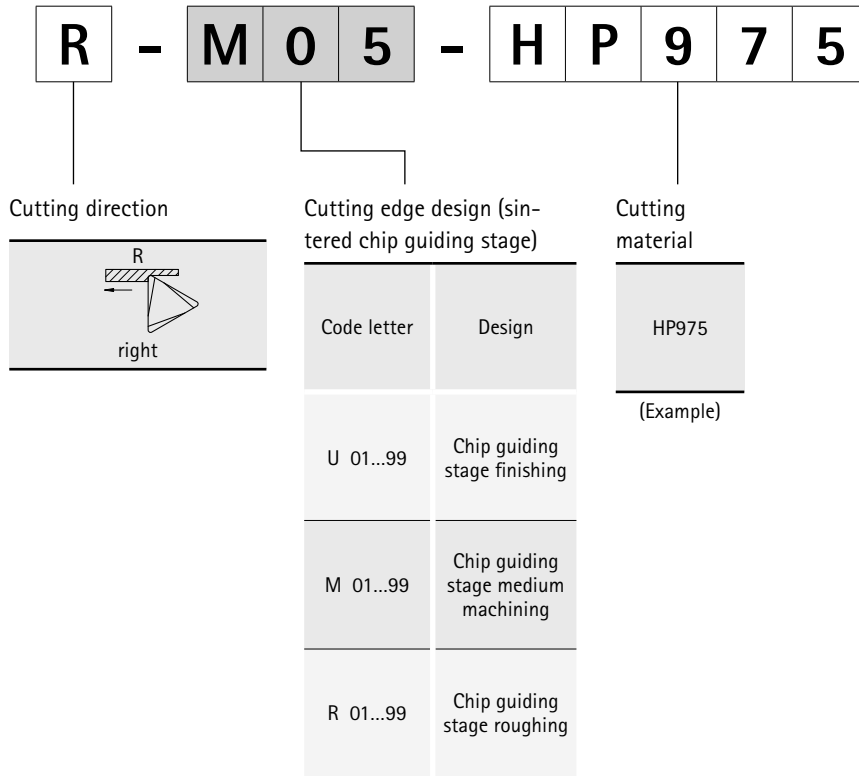

Product ID codes

Tangential indexable inserts

C
T
H
Q
09
05
08

Insert form



C (80°)











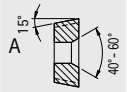

L (90°)

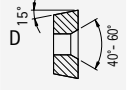

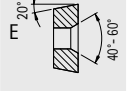

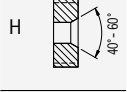
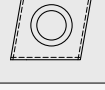
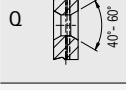
Tolerance

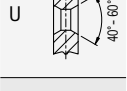
		
	d [mm]	s [mm]
H	±0.013	±0.025
G	±0.025	±0.13
N	±0.05 - ±0.15	±0.025
M	±0.05 - ±0.15	±0.13

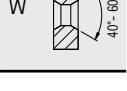
Insert type

Insert size

Incircle		
d [mm]	C	L
6.35	06 / 09	-
10.16	-	-
9.525	09 / 13	15
12.7	12 / 18	-
13.65	-	-

Insert thickness

	Key figure	s [mm]
	03	3.18
	T3	3.97
	04	4.76
	05	5.56
	06	6.35
	07	7.94

Indexable insert

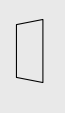

T

Tangential

Corner radius

	Identifica- tion number	r [mm]
	00	0
	04	0.4
	08	0.8
	12	1.2
	20	2.0
	30	3.0

H 1 2 **R** **9 0** **M 0 1 8** - **H P 9 6 5**

Cutting edge design

Code letter
A 01...99
C 01...99
D 01...99
G 01...99
H 01...99

Cutting direction

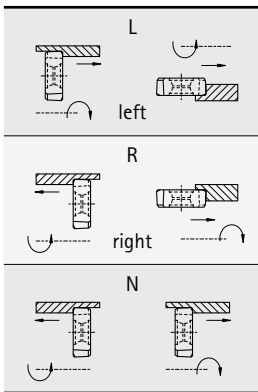

Contact angle

Identification number	Angle
90	90°
75	75°

Finishing cutting edge

Identification number	Length [mm]
M008	0.8
M012	1.2
M018	1.8

Identification number	Radius
M050	R 050
M100	R 100

Cutting material

HP965
(Example)

Product ID codes

PCD milling cartridge

P B C - 6 1 1 - 1 - P U 6 1 1

Milling cartridge		Type		Rake angle		Cutting edge form		Running direction		Cutting material	
PBC	NeoMill-Diamond-PowerBlue	6	Corner milling blade	1	6°	1	R _z value ≤ 5 μm / radius*	0	Clockwise	PU	PCD
PMC	NeoMill-Diamond-Power	7	Face milling insert	2	3°	2	R _z value ≤ 10 μm	1	Anticlockwise		
EMC	NeoMill-Diamond-Eco	8	Wide face milling blade	3	0°	3	R _z value ≤ 20 μm				
FMC	NeoMill-Diamond-FlyCutter	9	PT milling insert	4	10°	4	R _z value > 20 μm				
EBC	NeoMill-Diamond-EcoBlue			5	15°						
RBC	NeoMill-Diamond-RapidBlue			X	Custom						

Specification, MFS milling head holder

M F S 2 0 1 N - M 0 8

Holder type		Series		Coolant supply		Design		MFS connection size	
MFS	Milling head holder Metric Fitting System	10	Cylindrical design	0	External coolant supply	N	Standard design	M08	Metric ISO M8 thread (example)
		20	Conical design	1	Internal coolant supply				

* Only with wide face milling blade type.

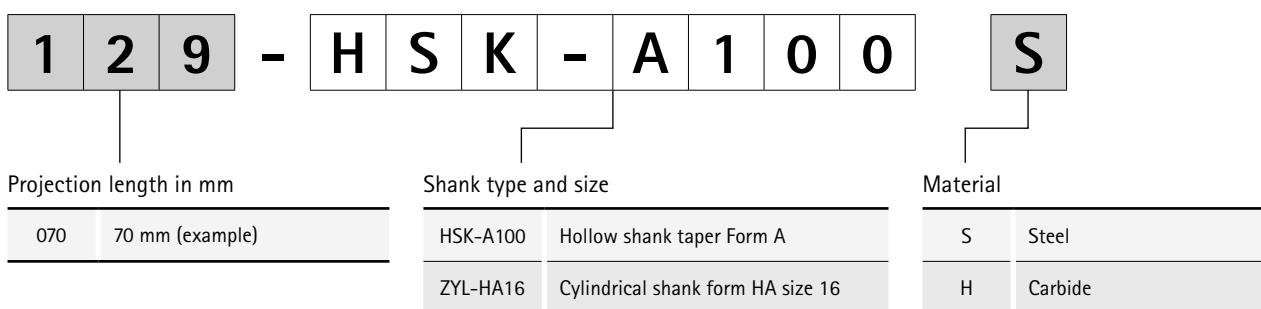



FACE MILLING CUTTER

Face milling cutter with indexable inserts

NeoMill – radial technology	
NeoMill-8-Face, OFMT07	250
NeoMill-16-Face, ONKU07	252
TGMill – tangential technology	
TGMill-4-Face45, LTHU15	254

Face milling cutter with PCD

System delimitation: Power and Eco	258
NeoMill-Diamond System Power	
Introduction to the technology	260
NeoMill-Diamond-Power and PMC milling cartridge	262
NeoMill-Diamond-PowerBlue and PBC milling cartridge	266
NeoMill-Diamond System Eco	
Introduction to the technology	270
NeoMill-Diamond-Eco and EMC milling cartridge	272
NeoMill-Diamond-EcoBlue and EBC milling cartridge	276
NeoMill-Diamond-RapidBlue and RBC milling cartridge	280
NeoMill-Diamond-FlyCutter and FMC milling cartridge	282
FaceMill series	
Introduction to the technology	284
FaceMill-Diamond	286

Accessories and spare parts

Face milling cutter with indexable inserts	
Accessories for indexable inserts	384
Allocating milling cutter clamping screws	386
Face milling cutter with PCD	
Milling cutters with PCD milling cartridges – Power system	378
Milling cutters with PCD milling cartridges – Eco system	380

Technical appendix

Cutting data recommendations	256
Handling notes NeoMill-8/16-Face	410
Handling notes Power milling head system	406
Handling notes Eco milling head system	408
Handling notes Milling cutter clamping screw	412
Reconditioning for face milling heads with PCD	414

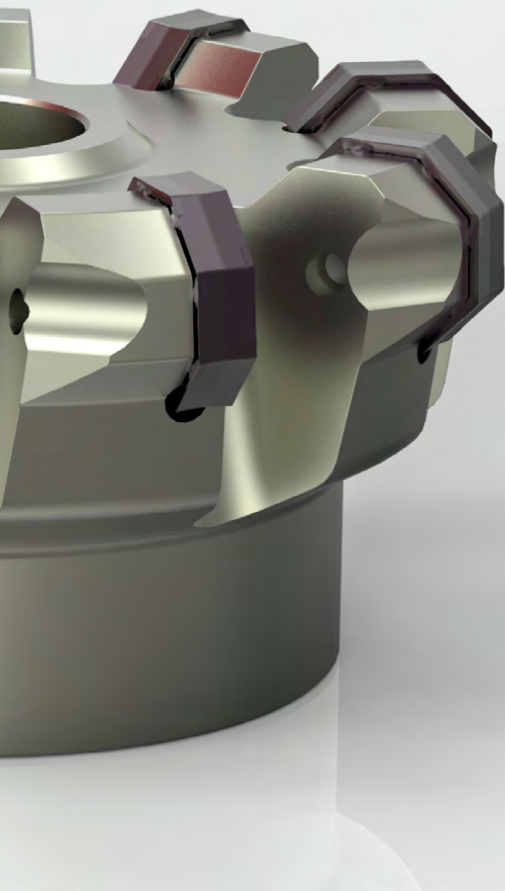

NeoMill®-8-Face

45° face milling cutter, with radial technology
OFMT07

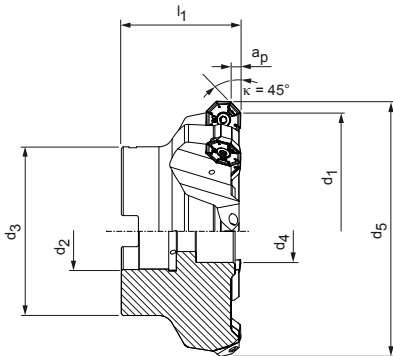

Milling cutter head, close spacing

Dimensions						z_{eff}	a_p max.	Weight [kg]	Max. operating speed [min^{-1}]	Internal cooling	Specification	Order no.
d_1	d_2	d_3	d_4	d_5	l_1							
63	22	48	18	75,5	40	5	5	0,6	15.800	✓	IFM451-063-CA22-Z05R-OF_T07	31002131
80	27	60	20	92,4	50	6	5	1,2	14.300	✓	IFM451-080-CA27-Z06R-OF_T07	31002132
100	32	78	27	111,3	55	8	5	2,1	12.900	✓	IFM451-100-CA32-Z08R-OF_T07	31002133
125	40	89	33	137,3	63	10	5	3,6	11.700	✓	IFM451-125-CA40-Z10R-OF_T07	31002134
160	40	89	65	172	63	13	5	5,4	10.400	-	IFM450-160-CA40-Z13R-OF_T07	31002136
200	60	140	-	212,3	63	15	5	9,1	9.400	-	IFM450-200-CA60-Z15R-OF_T07	31002137

Dimensions in mm.

The maximum operating speeds refer only to the cutting edge system.

OFMT

Radial indexable insert, eight cutting edges





Workpiece material	P				M	
	Unalloyed Wear-resistant	Alloyed Tough/Ductile	Unalloyed Wear-resistant	Alloyed Tough/Ductile	Austenitic Wear-resistant	Ferritic Tough/Ductile
Substrate	Carbide				Carbide	
Coating	PVD		CVD		PVD	
Cutting material type	HP980		HC775		HP980	HP985
Cutting edge design	M03		M03		M03	M03
OFMT07	a_p max. [mm]					
OFMT070405R-	*	31029307	31124599	31029307	31029341	

Feed per tooth

Application	Medium machining		
Cutting edge design	M03		
Coating	PVD	CVD	
Edge rounding	++	++	
Feed/tooth [mm]	P	0.1 - 0.3	0.1 - 0.23
	M	0.1 - 0.25	0.1 - 0.19
	K		
	N		

Legend: ++ = medium rounded

Accessories

	OFMT0704	Indexable inserts	Page 251
		Milling cutter arbor for milling cutter head see MAPAL catalogue "CLAMPING"	
		Milling cutter clamping screw for milling cutter head	Page 386

Spare parts**

	OFMT0704	Clamping screw for indexable insert TORX PLUS® M5x13-TX20-IP	Order no. 10105084
-------------------------------------------------------------------------------------	----------	--------------------------------------------------------------	-----------------------

* a_p max. depends on the type of milling cutter and application.

** Included in scope of delivery.

For cutting data recommendations, see end of chapter.

NeoMill®-16-Face

45° face milling cutter, with radial technology
ONKU07

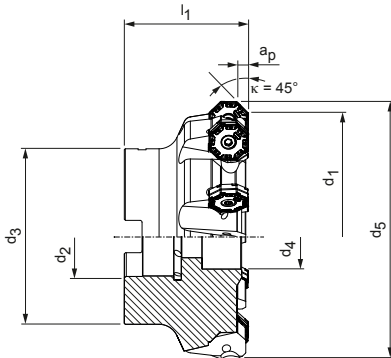

Milling cutter head, medium spacing

Dimensions						z_{eff}	a_p max.	Weight [kg]	Max. operating speed [min^{-1}]	Internal cooling	Specification	Order no.
d_1	d_2	d_3	d_4	d_5	l_1							
63	22	48	18	75,1	50	6	4	0,8	6.800	✓	IFM451-063-CA22-Z06R-ON_U07	31002143
80	27	60	20	92,1	50	7	4	1,2	6.100	✓	IFM451-080-CA27-Z07R-ON_U07	31002144
100	32	78	27	112,1	55	9	4	2,2	5.500	✓	IFM451-100-CA32-Z09R-ON_U07	31002145
125	40	89	33	137,1	63	10	4	3,7	5.000	✓	IFM451-125-CA40-Z10R-ON_U07	31002146
160	40	89	65	172,1	63	12	4	5,4	4.400	-	IFM450-160-CA40-Z12R-ON_U07	31002148
200	60	140	-	212,1	63	14	4	9,1	4.000	-	IFM450-200-CA60-Z14R-ON_U07	31002149

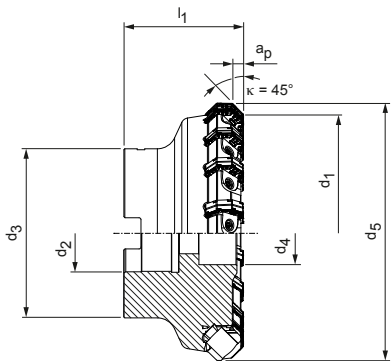

Milling cutter head, close spacing

Dimensions						z_{eff}	a_p max.	Weight [kg]	Max. operating speed [min^{-1}]	Internal cooling	Specification	Order no.
d_1	d_2	d_3	d_4	d_5	l_1							
63	22	48	18	75,1	55	7	3	1,1	9.000	-	IFM450-063-CA22-Z07R-ON_U07	31002155
80	27	60	20	92,1	50	11	3	1,5	7.800	-	IFM450-080-CA27-Z11R-ON_U07	31002156
100	32	78	27	112,1	55	14	3	2,5	6.800	-	IFM450-100-CA32-Z14R-ON_U07	31002157
125	40	89	33	137,1	63	18	3	4,1	5.900	-	IFM450-125-CA40-Z18R-ON_U07	31002158
160	40	89	65	172,1	63	23	3	6,1	5.000	-	IFM450-160-CA40-Z23R-ON_U07	31002160
200	60	140	-	212,1	63	30	3	10,1	4.200	-	IFM450-200-CA60-Z30R-ON_U07	31002161

Dimensions in mm.

The maximum operating speeds refer only to the cutting edge system.

ONKU

Radial indexable insert, 16 cutting edges

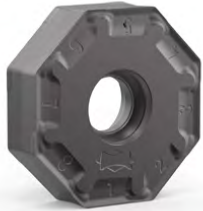



Workpiece material	P			M ₂		K			
	← Unalloyed Wear-resistant	Alloyed Tough/Ductile →		Austenitic Wear-resistant	Ferritic Tough/Ductile	GJL Wear-resistant	GJS Tough/Ductile	GJL Wear-resistant	GJS Tough/Ductile
Substrate	Carbide			Carbide		Carbide			
Coating	PVD		CVD	PVD		PVD		CVD	
Cutting material type	HP975	HP980	HC775	HP980	HP985	HP965	HP975	HC760	HC770
Cutting edge design			R05	R03	R03	R05	R05	R05	R05
ONKU07	a_p max. [mm]								
ONKU070508R-	*		31206555	31029361	31029362	31029363	31029360	31218299	31175603
Cutting edge design	M05	M03	M03	M03	M03	M05	M05	M05	M05
ONKU07	a_p max. [mm]								
ONKU070508R-	*	31029344	31029345	31271446	31029345	31029346	31029347	31029344	31122900

Feed per tooth



Application	Cutting edge design	Medium machining				Roughing			
		M03		M05		R03		R05	
Coating	Edge rounding	PVD	CVD	PVD	CVD	PVD	CVD	PVD	CVD
		++	++	+++	+++	++	++	+++	+++
Feed/tooth [mm]									
	P	0.1 - 0.3	0.1 - 0.23	0.12 - 0.35	0.12 - 0.27				0.12 - 0.35
	M	0.1 - 0.25	0.1 - 0.19			0.12 - 0.25	0.12 - 0.19		
	K			0.12 - 0.4	0.12 - 0.3			0.15 - 0.5	0.15 - 0.38
	N								

Legend: ++ = medium rounded | +++ = heavily rounded

Accessories

	ONKU0705	Indexable inserts	Page 253
		Milling cutter arbor for milling cutter head see MAPAL catalogue "CLAMPING"	
		Milling cutter clamping screw for milling cutter head	Page 386

Spare parts**

	ONKU0705 (close spacing)	Indexable insert clamping wedge	Order no. 31071645
	ONKU0705 (close spacing)	Threaded spindle M6x0.75 LH/RHx23.4 TX15 - IP	Order no. 31041869
	ONKU0705 (wide spacing)	Clamping screw for indexable insert TORX PLUS® M5x13-TX20-IP	Order no. 10105084

* a_p max. depends on the type of milling cutter and application.

** Included in scope of delivery.

For cutting data recommendations, see end of chapter.

M₂ Heat-resistant cast steel (turbocharger materials)

TGMill-4-Face45

45° face milling cutter, with tangential technology
LTHU15

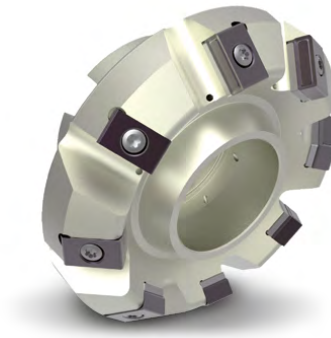
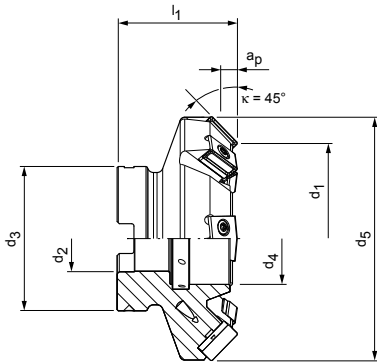

Dimensions						z _{eff}	a _p max.	Weight [kg]	Max. operating speed [min ⁻¹]	Internal cooling	Specification	Order no.
d ₁	d ₂	d ₃	d ₄	d ₅	l ₁							
80	27	60	38	104	50	8	8	1,3	11.000	✓	IFM451-080-CA27-Z8R-LT_U15	30635151
100	32	78	44	124	50	10	8	2,1	9.500	✓	IFM451-100-CA32-Z10R-LT_U15	30635152
125	40	89	56	149	50	14	8	3,8	8.300	✓	IFM451-125-CA40-Z14R-LT_U15	30635153
160	40	89	56	184	63	18	8	6,6	7.100	✓	IFM451-160-CA40-Z18R-LT_U15	30538444
200	60	140	-	224	63	22	8	9,6	6.100	✓	IFM451-200-CA60-Z22R-LT_U15	30635154

Accessories

	LTHU1505	Indexable inserts	Page 255
	LTHU1507	Indexable inserts	Page 255
		Milling cutter arbor for milling cutter head see MAPAL catalogue "CLAMPING"	
		Milling cutter clamping screw for milling cutter head	Page 386

Spare parts*

	LTHU1505 LTHU1507	TORX PLUS® M4x17-TX15-IP	Order no. 30414702
	LTHU1505	Backing plate 15.7x2.38x9.26	Order no. 30413233
	LTHU1505 LTHU1507	Threaded bush M6x0.5x12-sw4	Order no. 30413235

Selection notes

When using insert size LT_U1507, the backing plate must be removed

Fitting LT_U1505

Fitting LT_U1507

Dimensions in mm.

* Included in scope of delivery.

The maximum operating speeds refer only to the cutting edge system.

LTHU

Tangential indexable inserts, 4+4 cutting edge

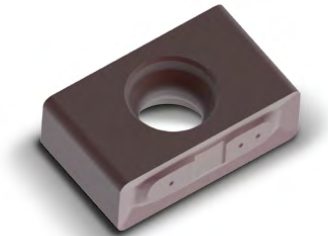

Workpiece material	P			K				
	Unalloyed Wear-resistant	Alloyed Tough/Ductile		GJL Wear-resistant	GJS Tough/Ductile	GJL Wear-resistant	GJS Tough/Ductile	
Substrate	Carbide			Carbide				
Coating	PVD		CVD	PVD		CVD		
Cutting material type	HP975	HP980	HC775	HP965	HP975	HC760	HC770	
Cutting edge design	H82	H82		H82	H82	H82	H82	
LTHU15	a_p max. [mm]							
LTHU150508...N-...	*	31177658	31177659		31177657	31177658	31272657	31272658
LTHU150512...N-...	*	31177662	31177663		31177661	31177662	31273026	31273027
LTHU150520...N-...	*	31177666	31177647		31177665	31177666	31273028	31273029
Cutting edge design	H92		H92	H92	H92	H92	H92	
LTHU15	a_p max. [mm]							
LTHU150508...N-...	*	30840002		30840014	31177639	30840002	31272670	30840012
LTHU150512...N-...	*	31177650			30259815	31177650	31272671	30954223
LTHU150520...N-...	*	31177654			31177653	31177654	31272674	30840860
LTHU150720...N-...	*				31177655			
LTHU150730...N-...	*				31177656			

Feed per tooth

Application		Roughing			
		H82		H92	
Cutting edge design		PVD	CVD	PVD	CVD
Coating					
Edge rounding		+++	+++	+++	+++
Feed/tooth [mm]	P	0.1 - 0.3	0.1 - 0.23	0.15 - 0.3	0.15 - 0.23
	M				
	K	0.1 - 0.35	0.1 - 0.27	0.15 - 0.35	0.15 - 0.27
	N				

Legend: +++ = heavily rounded

* a_p max. depends on the type of milling cutter and application.
 For related clamping screw and screwdriver see page 385.
 For cutting data recommendations, see end of chapter.

Cutting Data recommendation for Face Milling Cutter with Indexable Inserts

Feed and cutting speed

Face milling cutter

MMG*		Workpiece material	Strength/hardness [N/mm ²] [HRC]	Cooling			
				MQL/Air	Dry	Coolant	
P	P1	P1.1	Structural, free-cutting, case hardened and heat-treated steels, non-alloy	< 700		✓	
		P1.2	Structural, free-cutting, case hardened and heat-treated steels, non-alloy	< 1200		✓	
	P2	P2.1	Nitrided, case hardened and heat-treated steels, alloy	< 900		✓	
		P2.2	Nitrided, case hardened and heat-treated steels, alloy	< 1400		✓	
	P3	P3.1	Tool, bearing, spring and high-speed steels**	< 800		✓	
		P3.2	Tool, bearing, spring and high-speed steels**	< 1000		✓	
		P3.3	Tool, bearing, spring and high-speed steels**	< 1500		✓	
	P4	P4.1	Stainless steels, ferritic and martensitic				
	P5	P5.1	Cast steel				
	P6	P6.1	Stainless cast steel, ferritic and martensitic				
M	M1	M1.1	Stainless steels, austenitic	< 700		✓	
		M1.2	Stainless steels, ferritic/austenitic (duplex)	< 1000			
	M2	M2.1	Stainless/heat-resistant cast steel, austenitic	< 700			
	M3	M3.1	Stainless cast steel, ferritic/austenitic (duplex)	< 1000			
K	K1	K1.1	Cast iron with lamellar graphite (grey cast iron), GJL	< 300		✓	
		K2.1	Cast iron with spheroidal graphite, GJS	< 500		✓	
	K2	K2.2	Cast iron with spheroidal graphite, GJS	500-800			
		K2.3	Cast iron with spheroidal graphite, GJS	> 800			
	K3	K3.1	Cast iron with spheroidal graphite, GJV; malleable cast iron, GJM	< 500			
		K3.2	Cast iron with spheroidal graphite, GJV; malleable cast iron, GJM	> 500			

* MAPAL machining groups

** If the alloy parts Cr, Mo, Ni, V, W in total > 8%, then select the next highest MAPAL machining group.

v _c [m/min] according to cutting material type and contact ratio a _e /D														
Carbide PVD-coated								Carbide CVD-coated						
HP965		HP975		HP980		HP985		HC760		HC770		HC775		
> 0.6	< 0.6	> 0.6	< 0.6	> 0.6	< 0.6	> 0.6	< 0.6	> 0.6	< 0.6	> 0.6	< 0.6	> 0.6	< 0.6	
		180	220	180	220					260	280			
		150	180	150	180					250	270	240	260	
		160	200	160	200					240	260	230	250	
				130	160							220	240	
				130	160									
				130	160									
				120	150									
				120	150									
				130	160									
				110	140									
				160	180	140	170							
				140	160	120	150							
						100	120							
						90	110							
220	270	200	240					330	350	320	330			
200	240	180	220					300	330	300	320			
180	220	160	200							260	300			
160	200	140	170							220	260			
170	210	150	180					210	240	200	220			
160	200	140	170					200	220	180	200			

The specified machining values are guide values.

The optimum data for the respective machining task should be determined during the test or machining.

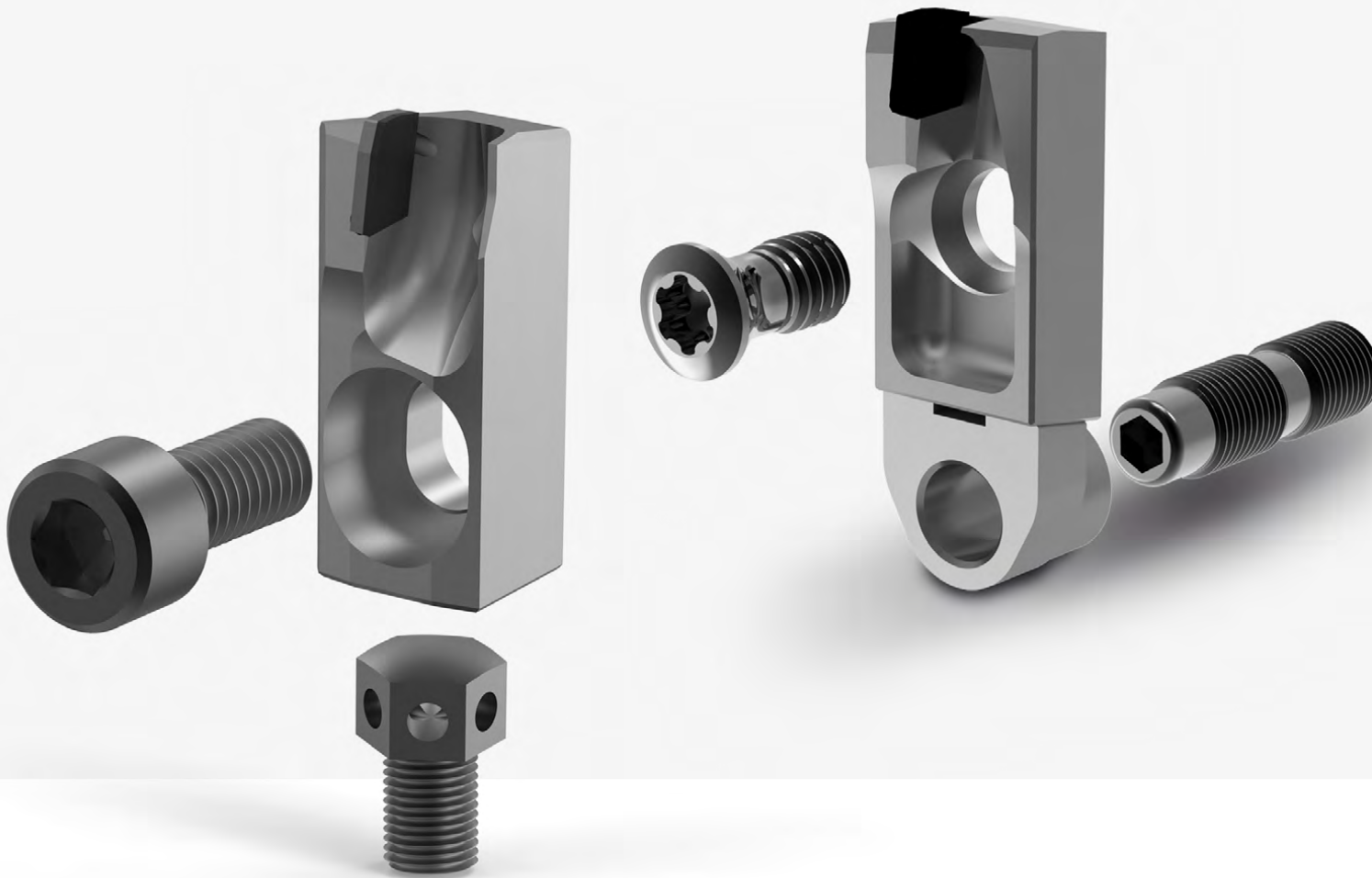

Milling head system NeoMill-Diamond Eco and Power

Proven in aluminium machining

Machining to the highest perfection

High removal rates, defined roughness depths or special requirements for the flatness of the part during face milling – the NeoMill-Diamond Eco and Power milling head systems provide the solution. Different numbers of teeth allow the optimal selection of the tool, with the aim of always achieving the highest economic efficiency for the milling process.

There are two variants to choose from: milling cartridges for the Eco system or the cost-effective 24-hour regrinding service for the Power system.

As a special service, MAPAL offers milling head management and reconditioning to original quality (for further information, see page 414).

NeoMill-Diamond-Eco and EcoBlue

This milling head system, primarily designed for finishing, impresses with a multitude of innovations. Perfect surface finishes are achieved with this milling cutter thanks to the sensitive, effective wedge adjustment of the cutting edges in the z-direction. When it comes to handling, the simple positioning of the milling insert in the aluminium base body is impressive. Centrifugal forces that occur during machining are compensated for by a precisely fitting dovetail guide. The use of disposable milling cartridge reduces the logistics effort. Integrated chip deflectors and direct cutting edge cooling on the NeoMill-Diamond-EcoBlue-series increase the tool life of the milling cutter base body.

NeoMill-Diamond-Power and PowerBlue

The Power milling head system is the all-rounder for roughing and finishing. The simple, robust design guarantees uncomplicated and quick adjustment of the tool. The NeoMill-Diamond-Power-series, the classic among the milling heads, has been continuously adapted to the growing requirements in machining. The main difference to the NeoMill-Diamond-Eco-series lies in the milling cartridge. In the NeoMill-Diamond-Power-series, the milling cartridges are designed with larger PCD tipping. In addition to the higher cutting depth of up to max. 5 mm, this also enables regrinding. Thanks to the exact manufacturing, the high-precision milling cartridge guarantees a perfect diameter of the cutting edges in the aluminium base body. The NeoMill-Diamond-Power-Blue-series features integrated chip deflectors and internal cooling directly onto the cutting edges.

1. Milling head system

System Power

All-rounder for roughing and finishing
 Robust adjusting screw
 Cutting depth up to 5 mm
 Can be reground

Robust adjusting screw

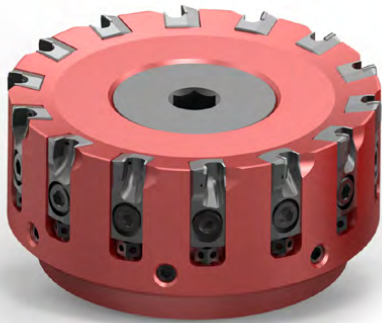

System Eco

1. Choice for finishing
 Sensitive wedge adjustment
 Cutting depth up to 3 mm
 Disposable milling cartridges

Sensitive wedge adjustment



2. Series

NeoMill-Diamond-Power



NeoMill-Diamond-PowerBlue



NeoMill-Diamond-Eco



NeoMill-Diamond-EcoBlue



3. Design*

Ex.: NeoMill-Diamond-PowerBlue

Wide spacing

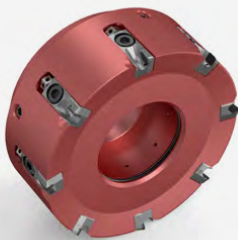

Close spacing



Monobloc design

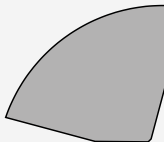
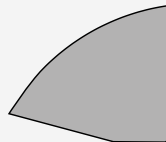
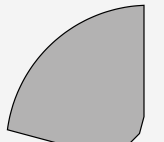
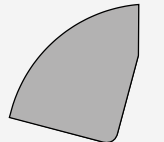

4. Cutting edge geometry of the milling inserts*

Standard geometries		Special geometries	
Face milling insert	Corner milling blade	Wide face milling blade	PT milling insert
			
Face milling	Shoulder milling	Face milling insert with wide finishing cutting edge	Generation of defined roughness depths

"BLUE" SERIES FEATURES

- Less chips and dirt in the finished part
Innovative chip guiding geometry
- Direct coolant supply
Integrated coolant outlets
- Reduced noise level
Minimum cutting edge overhang
- Suitable for dry machining and MQL applications
Integrated coolant outlets

* Valid for all series.



Power milling head system

The robust all-rounder

The Power milling head system is characterised by its simple and robust design and is equally suitable for roughing and finishing operations in aluminium. The PCD milling cartridges can be adjusted quickly and easily by means of an adjusting screw. The adjusting screw ensures exact and safe adjustment of the axial run-out even under extreme operating conditions.

The main difference to the Eco milling head system is the milling cartridge. The milling cartridges of the Power system are designed with larger PCD tipping. In addition to the larger cutting depth of up to max. 5 mm, this also enables regrinding. Thanks to the exact manufacturing, the high-precision milling cartridge guarantees a perfect diameter of the cutting edges in the aluminium base body.

While the chip former is still integrated in the tool body of the classic NeoMill-Diamond-Power-series, the new generation of PCD face milling cutters, the NeoMill-Diamond-Power-Blue-series, convinces with PCD milling cartridges with integrated chip guiding geometry. The chips are reliably removed and scratches on the surface as well as transport scoring are virtually impossible. The result is even better surface finishes.

Instead of a central coolant supply, the cutting edges are directly supplied with cooling lubricant at the point of action. The coolant outlet is integrated into the milling cartridge. This means the NeoMill-Diamond-PowerBlue-series is also suitable for MQL operations (recommended up to \varnothing 125 mm). Compared with the traditional NeoMill-Diamond-Power-series, noise is minimised due to a low cutting edge overhang.

AT A GLANCE

- Tool of choice for aluminium machining
- Proven setting and clamping system
- Cutting depths up to $a_p = 5$ mm
- NeoMill-Diamond-PowerBlue with optimised chip guiding geometry and integrated coolant outlets

ADVANTAGES

- High process reliability even under extreme operating conditions
- Regrindable PCD milling cartridges for maximum cost effectiveness

Tool features in detail

NeoMill®-Diamond-Power NeoMill®-Diamond-PowerBlue

- 1 Central coolant supply**
- Coolant supplied indirectly via central coolant screw or cap
- 2 Replaceable chip deflector**
- Significant increase in the tool life of the aluminium tool body
- 3 Adjusting screw**
- Exact, reliable adjustment of the axial run-out even in extreme conditions
 - Simple handling
- 4 Special cutting edge geometry**
- Face milling insert
 - Corner milling blade
 - Wide face milling blade
 - PT milling insert for defined roughness depths
- 5 Safety screw**
- Milling cartridge sits perfectly in the tool body
- NeoMill-Diamond-Power with additional safety screw for HSC applications.**

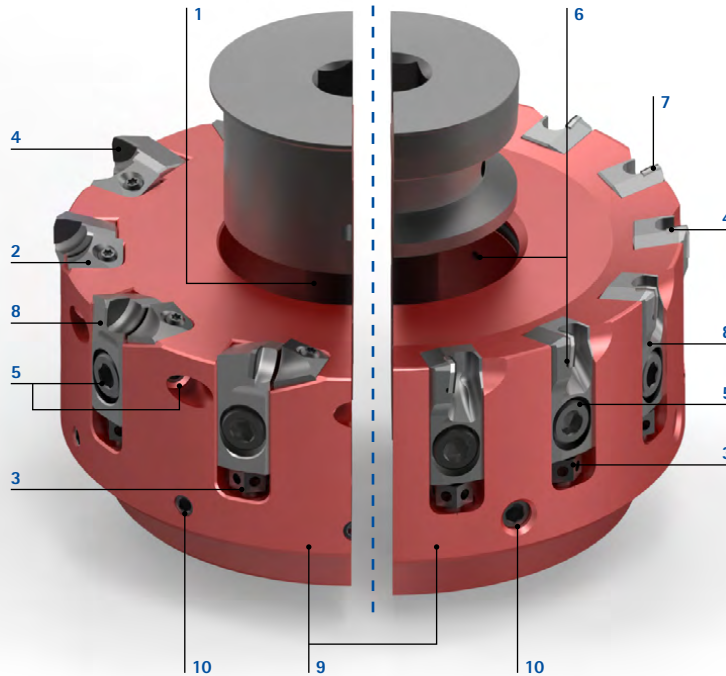

- 6 Integrated coolant outlets**
- Direct cooling and lubrication of the cutting edges
 - Suitable for dry machining and MQL applications
- 7 Minimised cutting edge overhang**
- Reduced noise level
- 8 Replaceable PCD milling cartridges**
- Long tool lifes
 - Special chip guiding geometry for targeted chip removal
 - Robust and regrindable
- 9 Tool body made of steel or high-strength aluminium**
- Wear-resistant
 - Lightweight design allows use at very high spindle speeds
- 10 Balancing screws**
- Perfect radial run-out due to balanced milling body

NeoMill-Diamond-Power

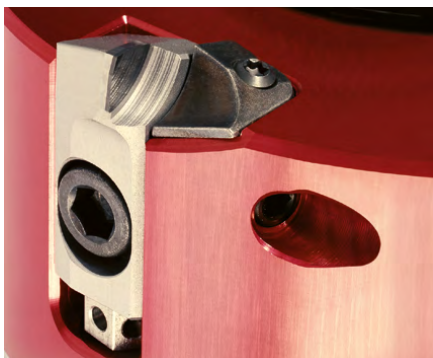

- Simple, robust construction
- Proven setting system ensures exact, reliable adjustment of the axial run-out even in extreme application conditions
- Milling cartridges that can be reground for high cost-effectiveness
- Cutting depths up to $a_p = 5$ mm
- Simple handling

NeoMill-Diamond-PowerBlue



- Chip former directly integrated into milling cartridge
- Significantly better surface finish
- Reliable chip removal
- No transport scoring on the part surface as the chips are removed

Special solutions



- NeoMill-Diamond-Power-series acts as the basis for customised special solutions
- In addition to milling heads with special dimensions, milling cartridges can be individually adapted to the machining task

Robust basic set-up for more process reliability even under extreme operating conditions.

NeoMill®-Diamond-Power

PCD face milling cutter, monoblock design PMC

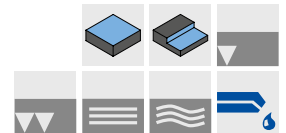
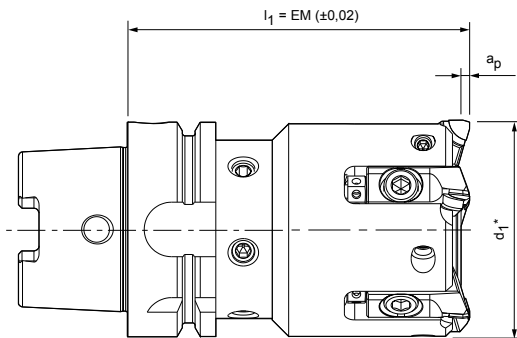





Tool body with HSK-A (hollow shank taper form A) connection

Dimensions			Z _{eff}	a _p max.	Weight incl. milling cartridges [kg]	Max. operating speed [min ⁻¹]	Specification	Order no.
d ₁ *	HSK-A nominal size	l ₁						
50	63	100	4	5	1,62	25.000	CFM901-050-A063-Z04R-PMC-S	30696673
63	63	100	5	5	2,05	24.360	CFM901-063-A063-Z05R-PMC-S	30696724
80	63	100	5	5	2,75	22.000	CFM901-080-A063-Z05R-PMC-S	30696726
100	63	100	6	5	3,83	19.000	CFM901-100-A063-Z06R-PMC-S	30696931

Accessories

	PMC...	Milling cartridge	Page 265
-------------------------------------------------------------------------------------	--------	-------------------	----------

Spare parts**

	d ₁ 50 - 100	Clamping screws for milling cartridge M6x13	Order no. 30696520
		Adjusting screw M5x8	Order no. 30696523
		Locking screw M6x12	Order no. 30696529
		Fastening screw with coolant delivery	Page 379
	HSK connection	HSK-A63 coolant tube	Order no. 30326006

Dimensions in mm.

Anticlockwise design on request.

Special design with increased number of teeth on request.

* d₁ Depending on the milling cartridge type, see page 265.

** Included in scope of delivery.

The maximum operating speeds refer only to the cutting edge system.

For cutting data recommendations, see end of chapter.

NeoMill®-Diamond-Power

PCD face milling head, wide spacing PMC

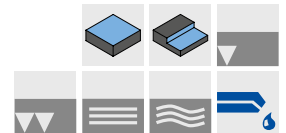
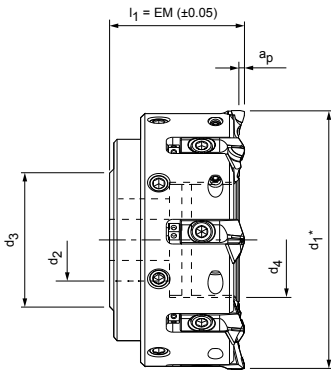

Tool body made of steel

Dimensions					Z _{eff}	a _p max.	Weight incl. milling cartridges [kg]	Max. operating speed [min ⁻¹]	Specification	Order no.
d ₁ *	d ₂	d ₃	d ₄	l ₁						
63	22	43	28	48	3	5	0,85	25.000	CFM901-063-CA22-Z03R-PMC-S	30696422
63	22	43	28	48	5	5	0,80	25.000	CFM901-063-CA22-Z05R-PMC-S	30696661

Tool body made of aluminium

80	27	49	36	50	5	5	0,75	25.000	CFM901-080-CA27-Z05R-PMC-A	30696424
80	27	49	36	50	6	5	0,75	25.000	CFM901-080-CA27-Z06R-PMC-A	30696659
80	27	49	36	50	7	5	0,8	25.000	CFM901-080-CA27-Z07R-PMC-A	30696663
100	32	59	45	50	6	5	1,08	21.650	CFM901-100-CA32-Z06R-PMC-A	30696426
100	32	59	45	50	8	5	1,20	21.650	CFM901-100-CA32-Z08R-PMC-A	30696665
125	40	71	56	63	8	5	2,20	18.550	CFM901-125-CA40-Z08R-PMC-A	30696428
125	40	71	56	63	10	5	2,20	18.550	CFM901-125-CA40-Z10R-PMC-A	30696667
140	40	100	56	63	10	5	2,40	18.550	CFM901-140-CA40-Z10R-PMC-A	30696430
160	40	104	-	63	10	5	2,75	14.990	CFM901-160-CA40-Z10R-PMC-A	30696432
160	40	98	-	63	12	5	2,80	14.990	CFM901-160-CA40-Z12R-PMC-A	30696669
180	40	104	-	63	10	5	3,40	13.500	CFM901-180-CA40-Z10R-PMC-A	30696434
200	60	138	-	63	12	5	4,15	12.200	CFM901-200-CA60-Z12R-PMC-A	30696436
250	60	138	-	63	15	5	6,70	9.760	CFM901-250-CA60-Z15R-PMC-A	30696438

Accessories

	PMC...	Milling cartridge	Page 265
		Milling cutter arbor for milling cutter head see MAPAL catalogue "CLAMPING"	
	d ₁	Fastening screw for milling cutter arbor	Order no.
	160 - 180 200 - 250	ISO 4762 - M12x45-12.9 ISO 4762 - M16x50-12.9	10006594 10007775

Spare parts**

		Clamping screws for milling cartridge M6x13	Order no.
			30696520
		Adjusting screw M5x8	Order no.
			30696523
		Chip deflector	Order no.
		Chip deflector for clockwise Chip deflector for anticlockwise	30696535 30696536
		Clamping screw for chip deflector M3x7.3	Order no.
			30696537
		Locking screw M6x12	Order no.
			30696529
	d ₁ 50 - 140	Fastening screw with coolant delivery	Page 379
	d ₁ 160 - 250	Coolant cover and fastening screw M6x20	Page 379

Dimensions in mm.

Anticlockwise design on request.

* d₁ Depending on the milling cartridge type, see page 265.

** Included in scope of delivery.

The maximum operating speeds refer only to the cutting edge system.

For cutting data recommendations, see end of chapter.

NeoMill®-Diamond-Power

PCD face milling head, close spacing PMC

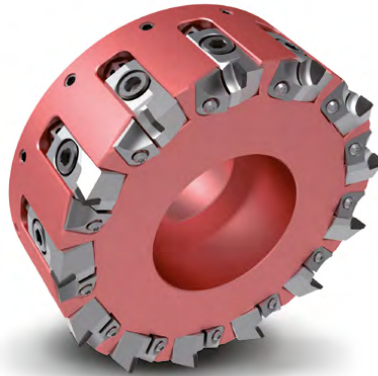
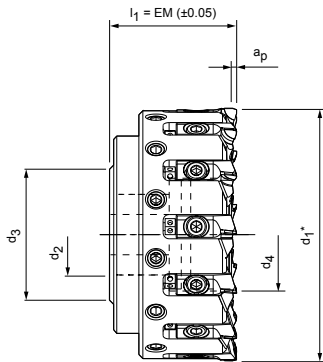

Tool body made of steel

Dimensions					Z _{eff}	a _p max.	Weight incl. milling cartridges [kg]	Max. operating speed [min ⁻¹]	Specification	Order no.
d ₁ *	d ₂	d ₃	d ₄	l ₁						
63	22	43	28	48	8	5	0,80	25.000	CFM901-063-CA22-Z08R-PMC-S	30696548

Tool body made of aluminium

80	27	49	36	50	8	5	0,83	20.000	CFM901-080-CA27-Z08R-PMC-A	30696550
100	32	59	45	50	10	5	1,20	18.000	CFM901-100-CA32-Z10R-PMC-A	30696552
125	40	71	56	63	12	5	2,25	18.550	CFM901-125-CA40-Z12R-PMC-A	30696671
125	40	71	56	63	13	5	2,20	16.000	CFM901-125-CA40-Z13R-PMC-A	30696554
160	40	98	-	63	18	5	2,15	13.000	CFM901-160-CA40-Z18R-PMC-A	30696556
180	40	104	-	63	20	5	2,60	11.500	CFM901-180-CA40-Z20R-PMC-A	30696558
200	60	138	-	63	24	5	4,40	10.000	CFM901-200-CA60-Z24R-PMC-A	30696560
250	60	138	-	63	30	5	7,00	8.000	CFM901-250-CA60-Z30R-PMC-A	30696562

Accessories

	PMC...	Milling cartridge	Page 265
		Milling cutter arbor for milling cutter head see MAPAL catalogue "CLAMPING"	
	d ₁	Fastening screw for milling cutter arbor	Order no.
	160 - 180 200 - 250	ISO 4762 - M12x45-12.9 ISO 4762 - M16x50-12.9	10006594 10007775

Spare parts**

		Clamping screws for milling cartridge M6x13	Order no. 30696520
		Adjusting screw M5x8	Order no. 30696523
		Chip deflector	Order no.
		Chip deflector for clockwise Chip deflector for anticlockwise	30696535 30696536
		Clamping screw for chip deflector M3x7.3	Order no. 30696537
	d ₁ 63 - 125	Fastening screw with coolant delivery	Page 379
	d ₁ 160 - 250	Coolant cover and fastening screw M6x20	Page 379

Dimensions in mm.

Anticlockwise design on request.

Special design with increased number of teeth on request.

* d₁ Depending on the milling cartridge type, see page 265.

** Included in scope of delivery.

The maximum operating speeds refer only to the cutting edge system.

For cutting data recommendations, see end of chapter.

PMC milling cartridge

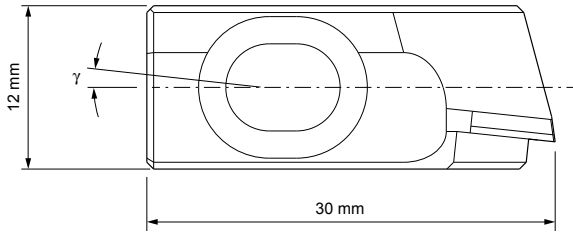

Milling cartridge – face milling inserts

	Rake angle γ [°]	R_z value [μm]	a_p max.	Cutting material	Cutting direction right	
					Specification	Order no.
	6	≤ 5	5	PU611	PMC-711-0-PU611	30696478
	6	≤ 10	5	PU611	PMC-712-0-PU611	30696482
	6	≤ 20	5	PU611	PMC-713-0-PU611	30696485
	6	> 20	5	PU611	PMC-714-0-PU611	30696488
	0	≤ 5	5	PU611	PMC-731-0-PU611	30696498
	0	≤ 10	5	PU611	PMC-732-0-PU611	30696504
	0	≤ 20	5	PU611	PMC-733-0-PU611	30696508
	0	> 20	5	PU611	PMC-734-0-PU611	30696511

Milling cartridge – corner milling blade

	6	≤ 5	5	PU611	PMC-611-0-PU611	30696446
	6	≤ 10	5	PU611	PMC-612-0-PU611	30696450
	6	≤ 20	5	PU611	PMC-613-0-PU611	30696452
	6	> 20	5	PU611	PMC-614-0-PU611	30696455
	0	≤ 5	5	PU611	PMC-631-0-PU611	30696466
	0	≤ 10	5	PU611	PMC-632-0-PU611	30696472
	0	≤ 20	5	PU611	PMC-633-0-PU611	30696474
	0	> 20	5	PU611	PMC-634-0-PU611	30696476

Special geometries

Assembly note:

In order to achieve defined surfaces, it can make sense to supplement a face or corner milling blade tipping with a process-dependent number of special geometries (wide finishing/PT).

Milling cartridge – wide face milling blade

	6	< 5	5	PU611	PMC-811-0-PU611	30696513
	0	< 3	5	PU611	PMC-831-0-PU611	30696516

Milling cartridge – PT milling insert

	0	-	5	PU611	PMC-931-0-PU611	30696518
--	---	---	---	-------	-----------------	----------

NeoMill®-Diamond-PowerBlue

PCD face milling cutter, monoblock design PBC

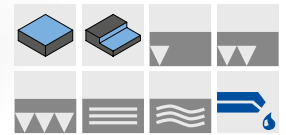
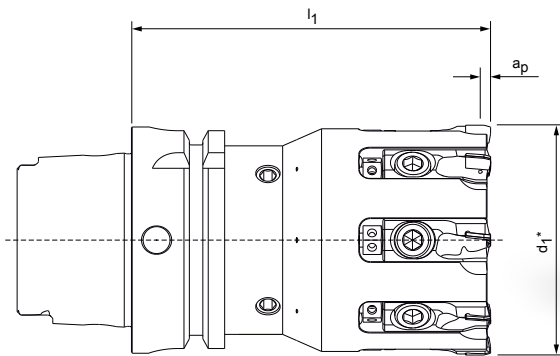





Tool body with HSK-A (hollow shank taper form A) connection

Dimensions			z_{eff}	a_p max.	Weight incl. milling cartridges [kg]	Max. operating speed [min^{-1}]	Specification	Order no.
d_1^*	HSK-A nominal size	l_1						
50	63	100	4	5	1,7	25.000	CFM901-050-A063-Z04R-PBC-S	30940663
63	63	100	8	5	2,1	25.000	CFM901-063-A063-Z08R-PBC-S	30940664
80	63	100	8	5	2,8	22.000	CFM901-080-A063-Z08R-PBC-S	30940665
100	63	100	10	5	3,8	18.000	CFM901-100-A063-Z10R-PBC-S	30940666

Accessories

	PBC	Milling cartridge	Page 269
-------------------------------------------------------------------------------------	-----	-------------------	----------

Spare parts**

	d_1 50 - 100	Clamping screws for milling cartridge M6x12 (flat head screw) M6x13	Order no. 30696520
		Adjusting screw M5x8	Order no. 30696523
	HSK connection	HSK-A63 coolant tube	Order no. 30326006
		Balancing screw M8x10	Order no. 10012538

Dimensions in mm.

Anticlockwise design on request.

Special design with increased number of teeth on request.

* d_1 Depending on the milling cartridge type, see page 269.

** Included in scope of delivery.

The maximum operating speeds refer only to the cutting edge system.

NeoMill®-Diamond-PowerBlue

PCD face milling head, wide spacing PBC

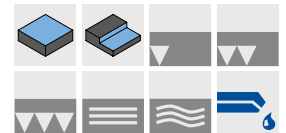
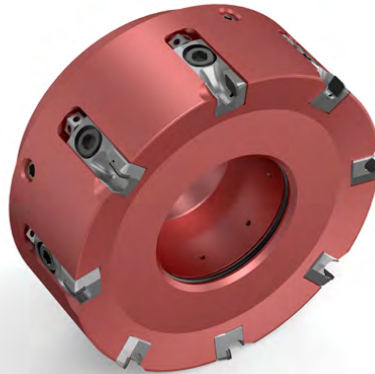
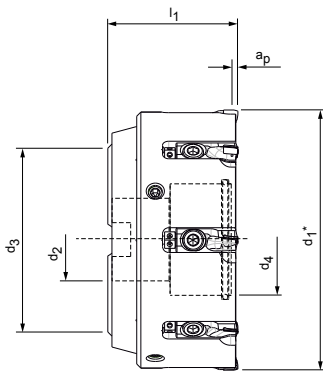

Tool body made of steel

Dimensions					Z_{eff}	a_p max.	Weight incl. milling cartridges [kg]	Max. operating speed [min^{-1}]	Specification	Order no.
d_1^*	d_2	d_3	d_4	l_1						
63	22	48	26	48	5	5	1,0	25.000	CFM901-063-CA22-Z05R-PBC-S	30940667
80	27	60	34	50	6	5	1,5	22.000	CFM901-080-CA27-Z06R-PBC-S	30940669
100	32	78	43	50	6	5	2,5	18.000	CFM901-100-CA32-Z06R-PBC-S	30940703
125	40	89	54	63	8	5	4,7	18.000	CFM901-125-CA40-Z08R-PBC-S	30982043

Tool body made of aluminium

100	32	78	43	50	6	5	1,1	20.000	CFM901-100-CA32-Z06R-PBC-A	30982041
125	40	89	54	63	8	5	2,1	18.000	CFM901-125-CA40-Z08R-PBC-A	30940705
160	40	130	-	63	10	5	2,6	14.000	CFM901-160-CA40-Z10R-PBC-A	30982047
200	60	134	-	63	12	5	3,8	11.000	CFM901-200-CA60-Z12R-PBC-A	30940720
250	60	134	-	63	15	5	6,1	8.500	CFM901-250-CA60-Z15R-PBC-A	30940724
315	60	232	-	80	18	5	12,0	7.250	CFM901-315-CA60-Z18R-PBC-A	30940726
400	60	232	-	80	24	5	19,0	6.100	CFM901-400-CA60-Z24R-PBC-A	30982048

Accessories

	PBC	Milling cartridge	Page 269
		Milling cutter arbor for milling cutter head see MAPAL catalogue "CLAMPING"	
	d_1 160 - 180 200 - 400	Fastening screws for milling cutter arbor ISO 4762 - M12x45-12.9 ISO 4762 - M16x50-12.9	Order no. 10006594 10007775

Spare parts**

		Clamping screws for milling cartridge M6x13	Order no. 30696520
		Adjusting screw M5x8	Order no. 30696523
	d_1 63 - 125	Fastening screw with coolant delivery	Page 379
	d_1 160 - 400	Coolant cover and fastening screw M6x20	Page 379
		Balancing screw	Page 378

Dimensions in mm.

Anticlockwise design on request.

Special design with increased number of teeth on request.

* d_1 Depending on the milling cartridge type, see page 269.

** Included in scope of delivery.

The maximum operating speeds refer only to the cutting edge system.

NeoMill®-Diamond-PowerBlue

PCD face milling head, close spacing PBC

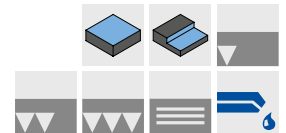
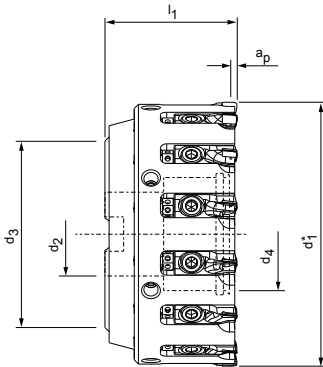

Tool body made of steel

Dimensions					Z _{eff}	a _p max.	Weight incl. milling cartridges [kg]	Max. operating speed [min ⁻¹]	Specification	Order no.
d ₁ *	d ₂	d ₃	d ₄	l ₁						
63	22	48	26	48	8	5	0,9	25.000	CFM901-063-CA22-Z08R-PBC-S	30940668
80	27	60	34	50	8	5	1,5	20.000	CFM901-080-CA27-Z08R-PBC-S	30940702
100	32	78	43	50	10	5	2,4	18.000	CFM901-100-CA32-Z10R-PBC-S	30940704
125	40	89	54	63	14	5	4,7	16.000	CFM901-125-CA40-Z14R-PBC-S	30982045

Tool body made of aluminium

100	32	78	43	50	10	5	1,2	18.000	CFM901-100-CA32-Z10R-PBC-A	30982042
125	40	89	54	63	14	5	2,2	16.000	CFM901-125-CA40-Z14R-PBC-A	30940706
160	40	96	-	63	18	5	2,7	13.000	CFM901-160-CA40-Z18R-PBC-A	30940708
200	60	134	-	63	24	5	4,0	10.000	CFM901-200-CA60-Z24R-PBC-A	30940721
250	60	134	-	63	30	5	6,4	8.000	CFM901-250-CA60-Z30R-PBC-A	30940725
315	60	232	-	80	36	5	12,3	7.000	CFM901-315-CA60-Z36R-PBC-A	30940727
400	60	232	-	80	48	5	19,4	5.500	CFM901-400-CA60-Z48R-PBC-A	30982049

Accessories

	PBC	Milling cartridge	Page 269
		Milling cutter arbor for milling cutter head see MAPAL catalogue "CLAMPING"	
	d ₁ 160 - 180 200 - 400	Fastening screws for milling cutter arbor ISO 4762 - M12x45-12.9 ISO 4762 - M16x50-12.9	Order no. 10006594 10007775

Spare parts**

		Clamping screws for milling cartridge M6x13	Order no. 30696520
		Adjusting screw M5x8	Order no. 30696523
	d ₁ 63 - 125	Fastening screw with coolant delivery	Page 379
	d ₁ 160 - 400	Coolant cover and fastening screw M6x18	Page 379
		Balancing screw	Page 378

Dimensions in mm.

Anticlockwise design on request.

Special design with increased number of teeth on request.

* d₁ Depending on the milling cartridge type, see page 269.

** Included in scope of delivery.

The maximum operating speeds refer only to the cutting edge system.

PBC milling cartridge

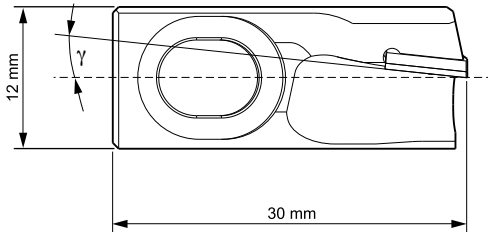

Milling cartridge – face milling inserts

	Rake angle γ [°]	R_z value [μm]	a_p max.	Running direction	Cutting material	Specification	Order no.
	6	≤ 5	5	Right	PU611	PBC-711-0-PU611	30956576
	6	≤ 10	5	Right	PU611	PBC-712-0-PU611	30956577
	6	≤ 20	5	Right	PU611	PBC-713-0-PU611	30956578
	6	> 20	5	Right	PU611	PBC-714-0-PU611	30956579
	0	≤ 5	5	Right	PU611	PBC-731-0-PU611	30956572
	0	≤ 10	5	Right	PU611	PBC-732-0-PU611	30956573
	0	≤ 20	5	Right	PU611	PBC-733-0-PU611	30956574
	0	> 20	5	Right	PU611	PBC-734-0-PU611	30956575

Milling cartridge – corner milling blade

	6	≤ 5	5	Right	PU611	PBC-611-0-PU611	30956584
	6	≤ 10	5	Right	PU611	PBC-612-0-PU611	30956585
	6	≤ 20	5	Right	PU611	PBC-613-0-PU611	30956586
	6	> 20	5	Right	PU611	PBC-614-0-PU611	30956587
	0	≤ 5	5	Right	PU611	PBC-631-0-PU611	30956580
	0	≤ 10	5	Right	PU611	PBC-632-0-PU611	30956581
	0	≤ 20	5	Right	PU611	PBC-633-0-PU611	30956582
	0	> 20	5	Right	PU611	PBC-634-0-PU611	30956583

Special geometries

Assembly note:

In order to achieve defined surfaces, it can make sense to supplement a face or corner milling blade tipping with a process-dependent number of special geometries (wide finishing/PT).

Milling cartridge – wide face milling blade

	0	< 3	2	Right	PU611	PBC-831-0-PU611	30961943
--	---	-------	---	-------	-------	-----------------	----------

Milling cartridge – PT milling insert

	0	-	2	Right	PU611	PBC-931-0-PU611	30961944
--	---	---	---	-------	-------	-----------------	----------



Eco milling head system

First choice for finishing

The Diamond-Eco milling head system is primarily designed for finishing operations in aluminium with high-quality surface finishes. As opposed to the Power system with regrindable milling cartridges, the Eco milling head system uses disposable milling cartridges that reduce logistical efforts. As there is less PCD tipping, the cutting depth is limited to max. 3 mm. The PCD cutting edges are fixed stably and securely by a highly precise dovetail guide. Changing the milling cartridges is quite straightforward. Adjustment is user-friendly with radially accessible, wedge-shaped adjusting elements. Integrated chip deflectors significantly increase the tool life of the cutter tool body.

While the classic NeoMill-Diamond-Eco-series already has an integrated chip guiding geometry, the innovative milling cartridges of the further developed NeoMill-Diamond-Eco-

Blue-series impress with a special chip guiding geometry that specifically keeps chips away from the component surface. This means that parts cleaning can be reduced to a minimum in series production.

With tough and long-chipping material, a significantly better surface finish is optically achieved and the risk of the formation of scratches is significantly reduced. This has advantages particularly during dry machining and with minimum quantity lubrication. The integrated coolant outlets in the milling cartridges ensure optimal cooling and lubrication of the PCD cutting edge, particularly with minimum quantity lubrication.

With the same basic set-up and even more cutting edges ($z = 28$ for tool diameter 125 mm), the RapidMill Blue series achieves the highest possible productivity in face milling.

AT A GLANCE

- 1. Choice for finishing aluminium
- Sensitive wedge adjustment
- Cutting depths up to $a_p = 3$ mm
- Disposable milling cartridges
- NeoMill-Diamond-EcoBlue with optimised chip guiding geometry and integrated coolant outlets

ADVANTAGES

- Superior surface finishes
- Setting of the axial run-out to the μm
- Easy handling

Tool features in detail

NeoMill®-Diamond-Eco NeoMill®-Diamond-EcoBlue

- 1 Central coolant supply**
 - Coolant supplied indirectly via central coolant screw or cap
- 2 High-accuracy wedge adjustment**
 - Simple handling
 - μm -precise setting of the axial run-out
- 3 Dovetail guide**
 - Exact positioning of the blades over the whole tool life
- 4 Replaceable PCD milling cartridges**
 - Long tool lifes
 - Special chip guiding geometry for targeted chip removal
- 5 Special cutting edge geometry**
 - Face milling insert
 - Corner milling blade
 - Wide face milling blade
 - PT milling insert for defined roughness depths

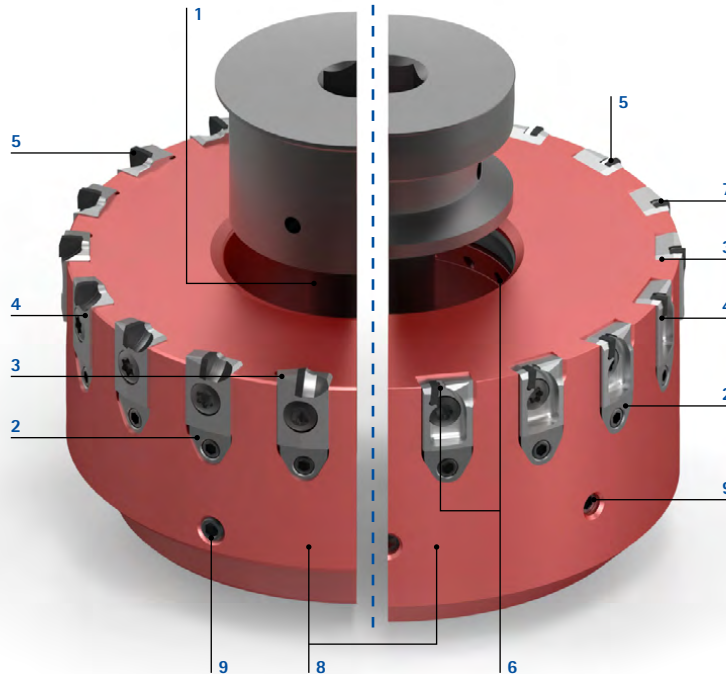

- 6 Integrated coolant outlets**
 - Direct cooling and lubrication of the cutting edges
 - Suitable for dry machining and MQL applications
- 7 Minimum cutting edge overhang**
 - Low noise
 - Very quiet running
- 8 Tool body made of steel or high-strength aluminium**
 - Wear-resistant
 - Lightweight design allows use at very high spindle speeds
- 9 Balancing screws**
 - Perfect radial run-out due to balanced milling body

NeoMill-Diamond-Eco



- Lightweight aluminium tool body
- Particularly sensitive adjustment for finishing operations
- Cost-effective disposable milling cartridge with smaller PCD cutting edges compared to the Power system

NeoMill-Diamond-Eco and -RapidBlue



- Innovative chip guiding geometry
- High process reliability as less chips and dirt in the finished part
- Direct cooling and lubrication of the cutting edges
- Significantly better surface finishes
- Suitable for dry machining and MQL applications

NeoMill-Diamond-FlyCutter



- Stress-free machining of the part due to highly positive cutting edge geometry
- Specially developed for very soft, long-chipping aluminium
- Suitable for machining vacuum-tensioned, thin-walled parts
- Weight reduction enables the use of larger diameters on small machines without exceeding the max. tool weight

Controlled chip removal for more quality, productivity, process reliability and longer tool life.

NeoMill®-Diamond-Eco

PCD face milling cutter, monoblock design EMC

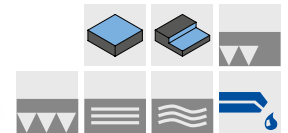
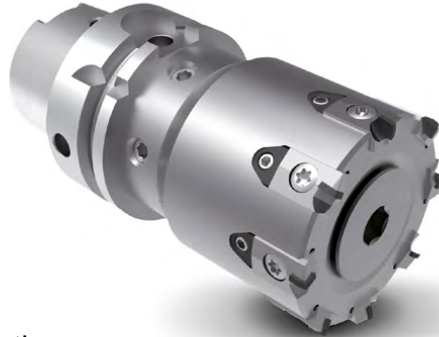
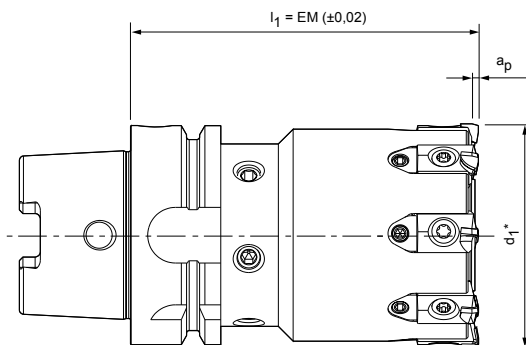





Tool body with HSK-A (hollow shank taper form A) connection

Dimensions			Z _{eff}	a _p max.	Weight incl. milling cartridges [kg]	Max. operating speed [min ⁻¹]	Specification	Order no.
d ₁ *	HSK-A nominal size	l ₁						
50	63	100	6	3	1,7	27.000	CFM901-050-A063-Z06R-EMC-S	30696632
63	63	100	8	3	2,12	27.000	CFM901-063-A063-Z08R-EMC-S	30696634
80	63	100	10	3	2,68	25.000	CFM901-080-A063-Z10R-EMC-S	30696636
100	63	100	14	3	3,45	20.000	CFM901-100-A063-Z14R-EMC-S	30696637

Accessories

	EMC...	Milling cartridge	Page 275
-------------------------------------------------------------------------------------	--------	-------------------	----------

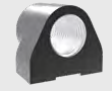
Spare parts**

		Clamping screws for milling cartridge M5x11	Order no. 30696524
		Threaded spindle M5x0.5LH/RHx17	Order no. 30696525
		Adjusting wedge M5x0.5	Order no. 30696526
		Fastening screw with coolant delivery	Page 381
	HSK connection	HSK-A63 coolant tube	Order no. 30326006

Dimensions in mm.

Special design with increased number of teeth on request.

* d₁ Depending on the milling cartridge type, see page 275.

** Included in scope of delivery.

The maximum operating speeds refer only to the cutting edge system.

For cutting data recommendations, see end of chapter.

NeoMill®-Diamond-Eco

PCD face milling head, wide spacing EMC

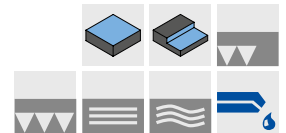
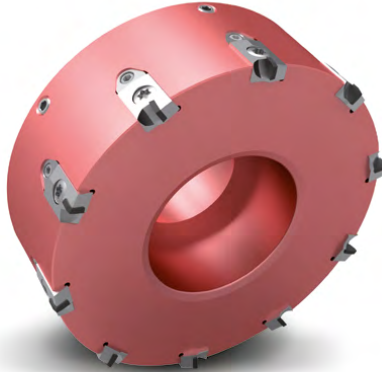
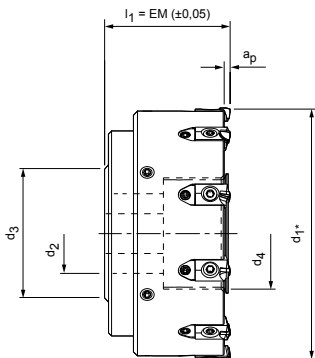

Tool body made of aluminium

Dimensions					Z _{eff}	a _p max.	Weight incl. milling cartridges [kg]	Max. operating speed [min ⁻¹]	Specification	Order no.
d ₁ *	d ₂	d ₃	d ₄	l ₁						
63	22	49	28	48	5	3	0,40	33.000	CFM901-063-CA22-Z05R-EMC-A	30696567
80	27	49	36	50	6	3	0,70	33.000	CFM901-080-CA27-Z06R-EMC-A	30696568
100	32	59	45	50	8	3	1,10	29.500	CFM901-100-CA32-Z08R-EMC-A	30696569
125	40	67	56	63	10	3	2,20	25.500	CFM901-125-CA40-Z10R-EMC-A	30696570
160	40	96	-	63	12	3	2,80	22.200	CFM901-160-CA40-Z12R-EMC-A	30696571
200	60	136	-	63	16	3	4,20	18.100	CFM901-200-CA60-Z16R-EMC-A	30696572
250	60	136	-	63	20	3	6,70	14.500	CFM901-250-CA60-Z20R-EMC-A	30696573

Accessories

	EMC	Milling cartridge	Page 275
		Milling cutter arbor for milling cutter head see MAPAL catalogue "CLAMPING"	
	d ₁ 160 200 - 250	Fastening screws for milling cutter arbor ISO 4762 - M12x45-12.9 ISO 4762 - M16x50-12.9	Order no. 10006594 10007775

Spare parts**

		Clamping screws for milling cartridge M5x11	Order no. 30696524
		Threaded spindle M5x0.5LH/RHx17	Order no. 30696525
		Adjusting wedge M5x0.5	Order no. 30696526
	d ₁ 63 - 125	Fastening screw with coolant delivery	Page 381
	d ₁ 160 - 250	Coolant cover and fastening screw M6x20	Page 381

Dimensions in mm.

* d₁ Depending on the milling cartridge type, see page 275.

** Included in scope of delivery.

The maximum operating speeds refer only to the cutting edge system.

For cutting data recommendations, see end of chapter.

NeoMill®-Diamond-Eco

PCD face milling head, close spacing EMC

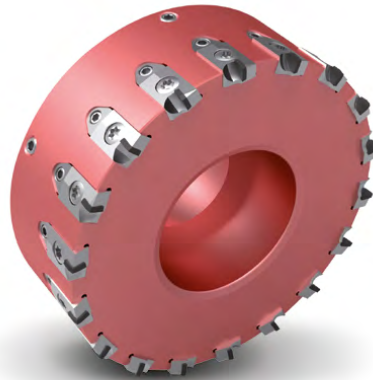
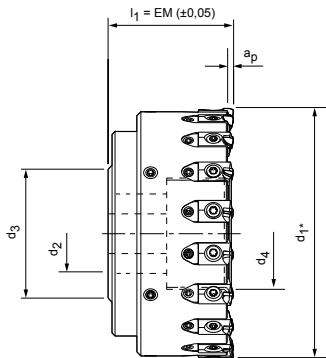

Tool body made of aluminium

Dimensions					Z _{eff}	a _p max.	Weight incl. milling cartridges [kg]	Max. operating speed [min ⁻¹]	Specification	Order no.
d ₁ *	d ₂	d ₃	d ₄	l ₁						
63	22	49	28	48	8	3	0,42	33.000	CFM901-063-CA22-Z08R-EMC-A	30696576
80	27	49	36	50	10	3	0,75	33.000	CFM901-080-CA27-Z10R-EMC-A	30696577
100	32	59	45	50	14	3	1,20	29.500	CFM901-100-CA32-Z14R-EMC-A	30696578
125	40	67	56	63	18	3	2,20	25.500	CFM901-125-CA40-Z18R-EMC-A	30696579
160	40	96	-	63	24	3	2,80	22.200	CFM901-160-CA40-Z24R-EMC-A	30696580
200	60	136	-	63	28	3	4,30	18.100	CFM901-200-CA60-Z28R-EMC-A	30696581
250	60	136	-	63	36	3	6,80	14.500	CFM901-250-CA60-Z36R-EMC-A	30696582

Accessories

	EMC	Milling cartridge	Page 275
		Milling cutter arbor for milling cutter head see MAPAL catalogue "CLAMPING"	
	d ₁ 160 200 - 250	Fastening screws for milling cutter arbor ISO 4762 - M12x45-12.9 ISO 4762 - M16x50-12.9	Order no. 10006594 10007775

Spare parts**

		Clamping screws for milling cartridge M5x11	Order no. 30696524
		Threaded spindle M5x0.5LH/RHx17	Order no. 30696525
		Adjusting wedge M5x0.5	Order no. 30696526
	d ₁ 63 - 125	Fastening screw with coolant delivery	Page 381
	d ₁ 160 - 250	Coolant cover and fastening screw M6x20	Page 381

Dimensions in mm.

Special design with increased number of teeth on request.

* d₁ Depending on the milling cartridge type, see page 275.

** Included in scope of delivery.

The maximum operating speeds refer only to the cutting edge system.

For cutting data recommendations, see end of chapter.

EMC milling cartridge

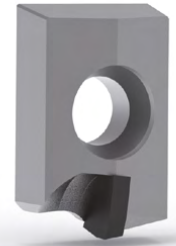
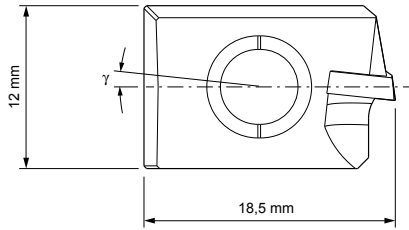

Milling cartridge – face milling inserts

	Rake angle γ [°]	R _z value [μm]	a _p max.	Running direction	Cutting material	Specification	Order no.
	6	≤ 5	3	Right	PU611	EMC-711-0-PU611	30696600
	6	≤ 10	3	Right	PU611	EMC-712-0-PU611	30696603
	6	≤ 20	3	Right	PU611	EMC-713-0-PU611	30696606
	6	> 20	3	Right	PU611	EMC-714-0-PU611	30696608
	0	≤ 5	3	Right	PU611	EMC-731-0-PU611	30696614
	0	≤ 10	3	Right	PU611	EMC-732-0-PU611	30696619
	0	≤ 20	3	Right	PU611	EMC-733-0-PU611	30696621
	0	> 20	3	Right	PU611	EMC-734-0-PU611	30696623

Milling cartridge – corner milling blade

	6	≤ 5	3	Right	PU611	EMC-611-0-PU611	30696585
	6	≤ 10	3	Right	PU611	EMC-612-0-PU611	30696588
	6	≤ 20	3	Right	PU611	EMC-613-0-PU611	30696589
	6	> 20	3	Right	PU611	EMC-614-0-PU611	30696590
	0	≤ 5	3	Right	PU611	EMC-631-0-PU611	30696595
	0	≤ 10	3	Right	PU611	EMC-632-0-PU611	30696597
	0	≤ 20	3	Right	PU611	EMC-633-0-PU611	30696598
	0	> 20	3	Right	PU611	EMC-634-0-PU611	30696599

Special geometries

Assembly note:

In order to achieve defined surfaces, it can make sense to supplement a face or corner milling blade tipping with a process-dependent number of special geometries (wide finishing/PT).

Milling cartridge – wide face milling blade

	6	< 5	3	Right	PU611	EMC-811-0-PU611	30696625
	0	< 3	3	Right	PU611	EMC-831-0-PU611	30696627

Milling cartridge – PT milling insert

	0	-	3	Right	PU611	EMC-931-0-PU611	30696631
--	---	---	---	-------	-------	-----------------	----------

NeoMill®-Diamond-EcoBlue

PCD face milling cutter, monoblock variant EBC

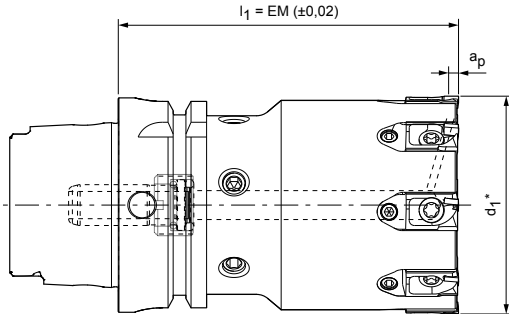





Tool body with HSK-A (hollow shank taper form A) connection

Dimensions			Z _{eff}	a _p max.	Weight incl. milling cartridges [kg]	Max. operating speed [min ⁻¹]	Specification	Order no.
d ₁ *	HSK-A nominal size	l ₁						
32	63	100	4	2	1,3	27.000	CFM901-032-A063-Z04R-EBC-S	30545054
40	63	100	6	2	1,45	27.000	CFM901-040-A063-Z06R-EBC-S	30545055
50	63	100	6	2	1,72	27.000	CFM901-050-A063-Z06R-EBC-S	30545056
63	63	100	8	2	2,18	27.000	CFM901-063-A063-Z08R-EBC-S	30545057
80	63	100	10	2	2,84	25.000	CFM901-080-A063-Z10R-EBC-S	30545058
100	63	100	14	2	3,58	20.000	CFM901-100-A063-Z14R-EBC-S	30545059

Accessories

	EBC...	Milling cartridge	Page 279
-------------------------------------------------------------------------------------	--------	-------------------	----------

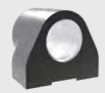
Spare parts**

		Clamping screws for milling cartridge TORX® M5x11 TX25	Order no. 30696524
	d ₁ 32 - 40 50 - 100	Threaded spindle M5x0.5LH/RHx15 M5x0.5LH/RHx17	Order no. 30696528 30696525
	d ₁ 32 - 40 50 - 100	Adjusting wedge M5x0.5 M5x0.5	Order no. 30696527 30696526
	HSK connection	HSK-63 coolant tube	Order no. 30326006

Dimensions in mm.

* d₁ Depending on the milling cartridge type, see page 279.

** Included in scope of delivery.

The maximum operating speeds refer only to the cutting edge system.

For cutting data recommendations, see end of chapter.

NeoMill®-Diamond-EcoBlue

PCD face milling head, wide spacing EBC

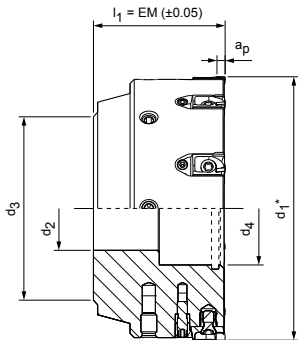



Tool body made of steel

Dimensions					Z _{eff}	a _p max.	Weight incl. milling cartridges [kg]	Max. operating speed [min ⁻¹]	Specification	Order no.
d ₁ *	d ₂	d ₃	d ₄	l ₁						
63	22	48	26	48	5	2	0,96	33.000	CFM901-063-CA22-Z05R-EBC-S	30569914
80	27	60	34	50	6	2	1,63	33.000	CFM901-080-CA27-Z06R-EBC-S	30569915
100	32	78	43	50	8	2	2,60	29.500	CFM901-100-CA32-Z08R-EBC-S	30569916
125	40	89	54	63	10	2	4,85	25.500	CFM901-125-CA40-Z10R-EBC-S	30569917
160	40	96	116,5	63	12	2	6,58	22.200	CFM901-160-CA40-Z12R-EBC-S	30569918





Tool body made of aluminium

63	22	48	26	48	5	2	0,43	33.000	CFM901-063-CA22-Z05R-EBC-A	30545037
80	27	60	34	50	6	2	0,71	33.000	CFM901-080-CA27-Z06R-EBC-A	30545038
100	32	78	43	50	8	2	1,13	29.500	CFM901-100-CA32-Z08R-EBC-A	30545039
125	40	89	54	63	10	2	2,08	25.500	CFM901-125-CA40-Z10R-EBC-A	30542646
160	40	-	116,5	63	12	2	2,52	22.200	CFM901-160-CA40-Z12R-EBC-A	30545040
200	60	-	156,5	63	16	2	3,80	18.100	CFM901-200-CA60-Z16R-EBC-A	30545041
250	60	-	206,5	63	20	2	6,11	14.500	CFM901-250-CA60-Z20R-EBC-A	30545042
315	60	-	271,5	80	24	2	12,15	11.500	CFM901-315-CA60-Z24R-EBC-A	30545052
400	60	-	356,5	80	28	2	19,00	9.000	CFM901-400-CA60-Z28R-EBC-A	30545044

Accessories

	EBC	Milling cartridge	Page 279
		Milling cutter arbor for milling cutter head see MAPAL catalogue "CLAMPING"	
	d ₁ 160 200 - 400	Fastening screws for milling cutter arbor ISO 4762 - M12x45-12.9 ISO 4762 - M16x50-12.9	Order no. 10006594 10007775

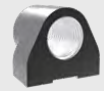
Spare parts**

		Clamping screws for milling cartridge TORX® M5x11 TX25	Order no. 30696524
		Threaded spindle M5x0.5LH/RHx17	Order no. 30696525
		Adjusting wedge M5x0.5	Order no. 30696526
	d ₁ 50 - 125	Fastening screw with coolant delivery	Page 381
	d ₁ 160 - 400	Coolant cover and fastening screw M6x20	Page 381

Dimensions in mm.

* d₁ Depending on the milling cartridge type, see page 279.

** Included in scope of delivery.

The maximum operating speeds refer only to the cutting edge system.

For cutting data recommendations, see end of chapter.

NeoMill®-Diamond-EcoBlue

PCD face milling head, close spacing EBC

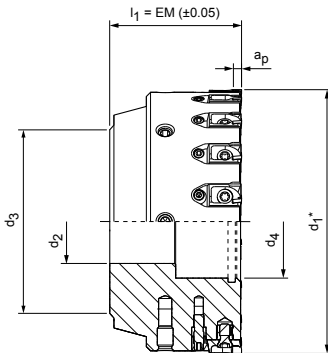

Tool body made of steel

Dimensions					Z _{eff}	a _p max.	Weight incl. milling cartridges [kg]	Max. operating speed [min ⁻¹]	Specification	Order no.
d ₁ *	d ₂	d ₃	d ₄	l ₁						
50	22	45	16	48	6	2	0,59	35.000	CFM901-050-CA22-Z06R-EBC-S	30569919
63	22	48	26	48	8	2	0,95	33.000	CFM901-063-CA22-Z08R-EBC-S	30569920
80	27	60	34	50	10	2	1,61	33.000	CFM901-080-CA27-Z10R-EBC-S	30569921
100	32	78	43	50	14	2	2,59	29.500	CFM901-100-CA32-Z14R-EBC-S	30569922
125	40	89	54	63	18	2	4,81	25.500	CFM901-125-CA40-Z18R-EBC-S	30569923
160	40	96	116,5	63	24	2	6,54	22.000	CFM901-160-CA40-Z24R-EBC-S	30569924

Tool body made of aluminium

50	22	45	16	48	6	2	0,28	35.000	CFM901-050-CA22-Z06R-EBC-A	30545045
63	22	48	26	48	8	2	0,45	33.000	CFM901-063-CA22-Z08R-EBC-A	30545046
80	27	60	34	50	10	2	0,73	33.000	CFM901-080-CA27-Z10R-EBC-A	30545047
100	32	78	43	50	14	2	1,17	29.500	CFM901-100-CA32-Z14R-EBC-A	30545048
125	40	89	54	63	18	2	2,14	25.500	CFM901-125-CA40-Z18R-EBC-A	30519037
160	40	-	116,5	63	24	2	2,60	22.200	CFM901-160-CA40-Z24R-EBC-A	30545049
200	60	-	156,5	63	28	2	3,88	14.500	CFM901-200-CA60-Z28R-EBC-A	30545050
250	60	-	206,5	63	36	2	6,22	14.500	CFM901-250-CA60-Z36R-EBC-A	30545051
315	60	-	271,5	80	46	2	12,29	11.500	CFM901-315-CA60-Z46R-EBC-A	30545043
400	60	-	356,5	80	58	2	19,21	9.000	CFM901-400-CA60-Z58R-EBC-A	30545053

Accessories

	EBC	Milling cartridge	Page 279
		Milling cutter arbor for milling cutter head see MAPAL catalogue "CLAMPING"	
	d ₁ 160 200 - 400	Fastening screws for milling cutter arbor ISO 4762 - M12x45-12.9 ISO 4762 - M16x50-12.9	Order no. 10006594 10007775

Spare parts**

		Clamping screws for milling cartridge TORX® M5x11 TX25	Order no. 30696524
		Threaded spindle M5x0.5LH/RHx17	Order no. 30696525
		Adjusting wedge M5x0.5	Order no. 30696526
	d ₁ 50 - 125	Fastening screw with coolant delivery	Page 381
	d ₁ 160 - 400	Coolant cover and fastening screw M6x20	Page 381

Dimensions in mm.

* d₁ Depending on the milling cartridge type, see page 279.

** Included in scope of delivery.

The maximum operating speeds refer only to the cutting edge system.

For cutting data recommendations, see end of chapter.

EBC milling cartridge

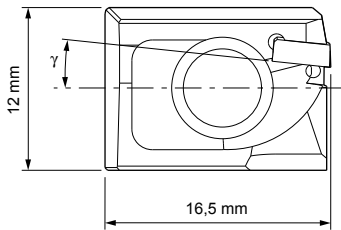

Milling cartridge – face milling inserts

	Rake angle γ [°]	R _z value [μm]	a _p max.	Running direction	Cutting material	Specification	Order no.
	0	≤ 5	2	Right	PU611	EBC-731-0-PU611	30559589
	0	≤ 10	2	Right	PU611	EBC-732-0-PU611	30559591
	0	≤ 20	2	Right	PU611	EBC-733-0-PU611	30559595
	0	> 20	2	Right	PU611	EBC-734-0-PU611	30559599
	6	≤ 5	2	Right	PU611	EBC-711-0-PU611	30502818
	6	≤ 10	2	Right	PU611	EBC-712-0-PU611	30559592
	6	≤ 20	2	Right	PU611	EBC-713-0-PU611	30559596
	6	> 20	2	Right	PU611	EBC-714-0-PU611	30559600

Milling cartridge – corner milling blade

	Rake angle γ [°]	R _z value [μm]	a _p max.	Running direction	Cutting material	Specification	Order no.
	0	≤ 5	2	Right	PU611	EBC-631-0-PU611	30559590
	0	≤ 10	2	Right	PU611	EBC-632-0-PU611	30559593
	0	≤ 20	2	Right	PU611	EBC-633-0-PU611	30559597
	0	> 20	2	Right	PU611	EBC-634-0-PU611	30559601
	6	≤ 5	2	Right	PU611	EBC-611-0-PU611	30518869
	6	≤ 10	2	Right	PU611	EBC-612-0-PU611	30559594
	6	≤ 20	2	Right	PU611	EBC-613-0-PU611	30559598
	6	> 20	2	Right	PU611	EBC-614-0-PU611	30559602

Special geometries

Assembly note:

In order to achieve defined surfaces, it can make sense to supplement a face or corner milling blade tipping with a process-dependent number of special geometries (wide finishing/PT).

Milling cartridge – wide face milling blade

	Rake angle γ [°]	R _z value [μm]	a _p max.	Running direction	Cutting material	Specification	Order no.
	0	< 3	2	Right	PU611	EBC-831-0-PU611	30542645

Milling cartridge – PT milling insert

	Rake angle γ [°]	R _z value [μm]	a _p max.	Running direction	Cutting material	Specification	Order no.
	0	≤ 5	2	Right	PU611	EBC-931-0-PU611	30559603

NeoMill®-Diamond-RapidBlue

PCD face milling head, close spacing RBC

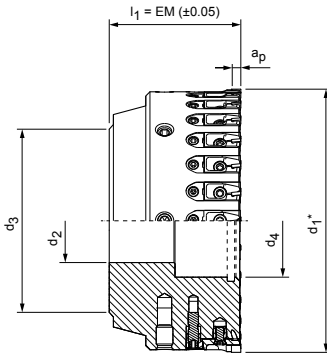

Tool body made of aluminium

Dimensions					Z _{eff}	a _p max.	Weight incl. milling cartridges [kg]	Max. operating speed [min ⁻¹]	Specification	Order no.
d ₁ *	d ₂	d ₃	d ₄	l ₁						
50	22	45	16	48	10	1	0,29	35.000	CFM901-050-CA22-Z10R-RBC-A	30547876
63	22	48	26	48	13	1	0,47	33.000	CFM901-063-CA22-Z13R-RBC-A	30547877
80	27	60	34	50	16	1	0,75	33.000	CFM901-080-CA27-Z16R-RBC-A	30547878
100	32	78	43	50	22	1	1,18	29.500	CFM901-100-CA32-Z22R-RBC-A	30547879
125	40	89	54	63	28	1	2,16	25.500	CFM901-125-CA40-Z28R-RBC-A	30547880
160	40	-	116,5	63	34	1	2,61	22.200	CFM901-160-CA40-Z34R-RBC-A	30547881
200	60	-	156,5	63	44	1	3,91	18.100	CFM901-200-CA60-Z44R-RBC-A	30547882

Accessories

	RBC	Milling cartridge	Page 281
		Milling cutter arbor for milling cutter head see MAPAL catalogue "CLAMPING"	
	d ₁ 160 200 - 400	Fastening screws for milling cutter arbor ISO 4762 - M12x45-12.9 ISO 4762 - M16x50-12.9	Order no. 10006594 10007775

Spare parts**

		Clamping screws for milling cartridge TORX PLUS® M4X8.5-TX15-IP	Order no. 30412229
	d ₁ 50 63 - 200	Threaded spindle M5x0.5LH/RHx15 M5x0.5LH/RHx17	Order no. 30696528 30696525
		Adjusting wedge M5x0.5	Order no. 30557564
	d ₁ 50 - 125	Fastening screw with coolant delivery	Page 381
	d ₁ 160 - 400	Coolant cover and fastening screw M6x20	Page 291

Dimensions in mm.

* d₁ Depending on the milling cartridge type, see page 281.

** Included in scope of delivery.

The maximum operating speeds refer only to the cutting edge system.

For cutting data recommendations, see end of chapter.

RBC milling cartridge

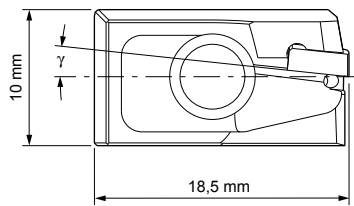

Milling cartridge – face milling inserts

	Rake angle γ [°]	R _z value [μm]	a _p max.	Running direction	Cutting material	Specification	Order no.
	0	≤ 5	1	Right	PU611	RBC-731-0-PU611	30560072
	0	≤ 10	1	Right	PU611	RBC-732-0-PU611	30560075
	0	≤ 20	1	Right	PU611	RBC-733-0-PU611	30560079
	0	> 20	1	Right	PU611	RBC-734-0-PU611	30560083
	6	≤ 5	1	Right	PU611	RBC-711-0-PU611	30547873
	6	≤ 10	1	Right	PU611	RBC-712-0-PU611	30560076
	6	≤ 20	1	Right	PU611	RBC-713-0-PU611	30560080
	6	> 20	1	Right	PU611	RBC-714-0-PU611	30560084

Milling cartridge – corner milling blade

	0	≤ 5	1	Right	PU611	RBC-631-0-PU611	30560073
	0	≤ 10	1	Right	PU611	RBC-632-0-PU611	30560077
	0	≤ 20	1	Right	PU611	RBC-633-0-PU611	30560081
	0	> 20	1	Right	PU611	RBC-634-0-PU611	30560085
	6	≤ 5	1	Right	PU611	RBC-611-0-PU611	30547874
	6	≤ 10	1	Right	PU611	RBC-612-0-PU611	30560078
	6	≤ 20	1	Right	PU611	RBC-613-0-PU611	30560082
	6	> 20	1	Right	PU611	RBC-614-0-PU611	30560086

Milling cartridge – wide face milling blade

	0	< 3	1	Right	PU611	RBC-831-0-PU611	30560087
--	---	-----	---	-------	-------	-----------------	----------

Milling cartridge – PT milling insert

	0	-	1	Right	PU611	RBC-931-0-PU611	30560088
--	---	---	---	-------	-------	-----------------	----------

NeoMill®-Diamond-FlyCutter

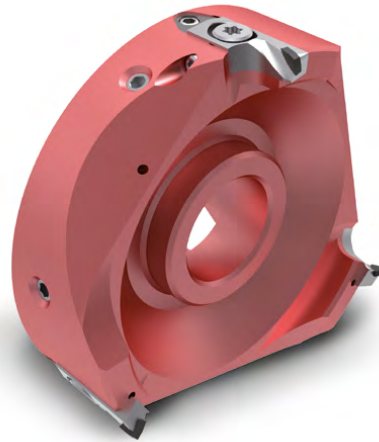
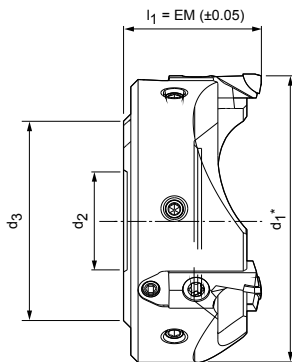

PCD face milling head, weight-reduced design FMC



Tool body made of aluminium

Dimensions				Z_{eff}	a_p max.	Weight incl. milling cartridges [kg]	max. operating speed [min^{-1}]	Specification	Order no.
d_1^*	d_2	d_3	l_1						
63	27	55	42	3	3	0,22	33.000	CFM901-063-CA27-Z03R-FMC-A	30772751
80	27	59	38	3	3	0,299	33.000	CFM901-080-CA27-Z03R-FMC-A	30388951-200
100	27	59	38	3	3	0,418	30.000	CFM901-100-CA27-Z03R-FMC-A	30381973-200
125	27	59	38	3	3	0,627	25.000	CFM901-125-CA27-Z03R-FMC-A	30388952-200
140	27	59	38	4	3	0,800	23.000	CFM901-140-CA27-Z04R-FMC-A	30466716-200
160	27	59	50	4	3	1,469	21.000	CFM901-160-CA27-Z04R-FMC-A	30508209

Accessories

	FMC...	Milling cartridge	Page 283
		See MAPAL catalogue "CLAMPING"	

Spare parts**

		Clamping screws for milling cartridge ISO 14580 – M5x8-8.8-KL	Order no. 30499981
		Threaded spindle M5x0.5LH/RHx17	Order no. 30696525
		Adjusting wedge M5x0.5	Order no. 30696526
		Locking screw ISO 4028 – M4x6-45H-KL	Order no. 30367364
	d_1 80 – 160	Fastening screw with coolant delivery and washer	Page 381

Dimensions in mm.

* d_1 Depending on the milling cartridge type, see page 283.

** Included in scope of delivery.

The maximum operating speeds refer only to the cutting edge system.

For cutting data recommendations, see end of chapter.

FMC milling cartridge

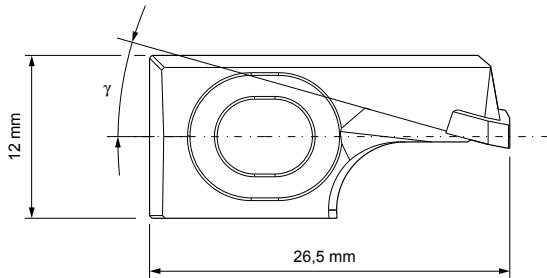

Milling cartridge – face milling inserts

	Rake angle γ [°]	R _z value [μm]	a _p max.	Running direction	Cutting material	Specification	Order no.
	15	≤ 5	3	Right	PU611	FMC-751-0-PU611	30410278-300
	15	> 20	3	Right	PU611	FMC-754-0-PU611	30410278-302

Milling cartridge – corner milling blade

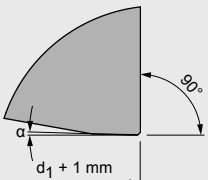
	15	≤ 10	3	Right	PU611	FMC-652-0-PU611	30410278-303
-------------------------------------------------------------------------------------	----	------	---	-------	-------	-----------------	--------------

Milling cartridge – wide face milling blade

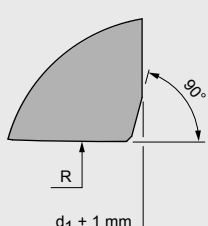
	10	≤ 5	3	Right	PU611	FMC-841-0-PU611	30410278-301
-------------------------------------------------------------------------------------	----	-----	---	-------	-------	-----------------	--------------

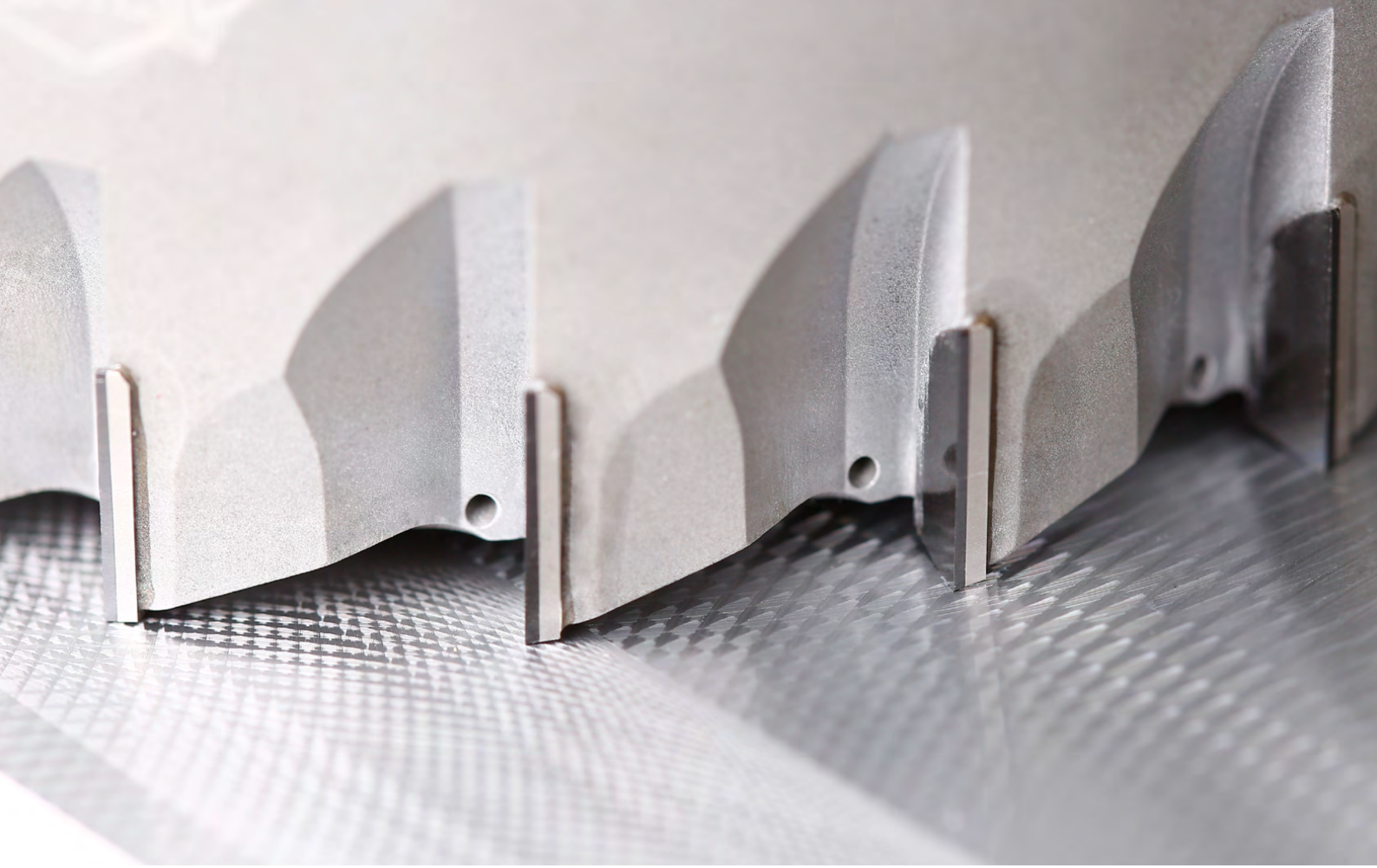

FaceMill-Diamond

Maximum number of teeth for high productivity

For many years, the FaceMill-Diamond PCD face milling cutter has been used worldwide with great success. It is particularly strong in HPC applications or when machining unstable parts – and that with cutting depths up to 10 mm. The monolithic design with brazed PCD cutting edges allows large numbers of teeth, thus enabling high feed rates and increased material removal rates. Machining with the FaceMill-Diamond results in very good surface finishes and long tool life.

The FaceMill-Diamond has been overhauled with the goal of making the proven solution even better. For optimal cooling and lubrication of the PCD cutting edges, the coolant outlets are positioned directly at the cutting edges in the new model. This feature ensures

improved chip removal and offers significant benefits, particularly in applications with minimum quantity lubrication or air cooling.

Based on requirements pertaining to more flexibility and independence from the machine connection, the product range was expanded to include a modular milling head variant: The face milling cutter is now available as a milling cutter head variant. The milling cutter can thus be used flexibly, in particular for small series with machinery with different connections or even for large series that are produced on another machine and then relocated.

AT A GLANCE

- Large number of fixed brazed PCD cutting edges
- Proven geometry variants available for different surface finish requirements ($\leq 10 \mu\text{m}$ / $> 10 \mu\text{m}$)
- Cutting depths of up to $a_p = 10 \text{ mm}$ possible

ADVANTAGES

- Improved chip removal and longer tool lives thanks to cooling directly at the cutting edge
- Cutterhead variant for flexible use with different machine connections

Tool features in detail

1 Brazed PCD cutting edge

- Cutting edges made of PCD for long tool lives
- High cutting depth of up to 10 mm possible

2 Proven cutting edge geometry

- Available for different surface finish requirements ($R_z \leq 10 \mu\text{m}$ / $> 10 \mu\text{m}$)

3 Integrated coolant outlets

- Direct cooling and lubrication of the cutting edges
- Improved chip removal

4 Tool body made of steel

- Wear-resistant and ductile
- Multiple reconditioning possible

5 Balancing screws

- Perfect radial run-out due to balanced milling body

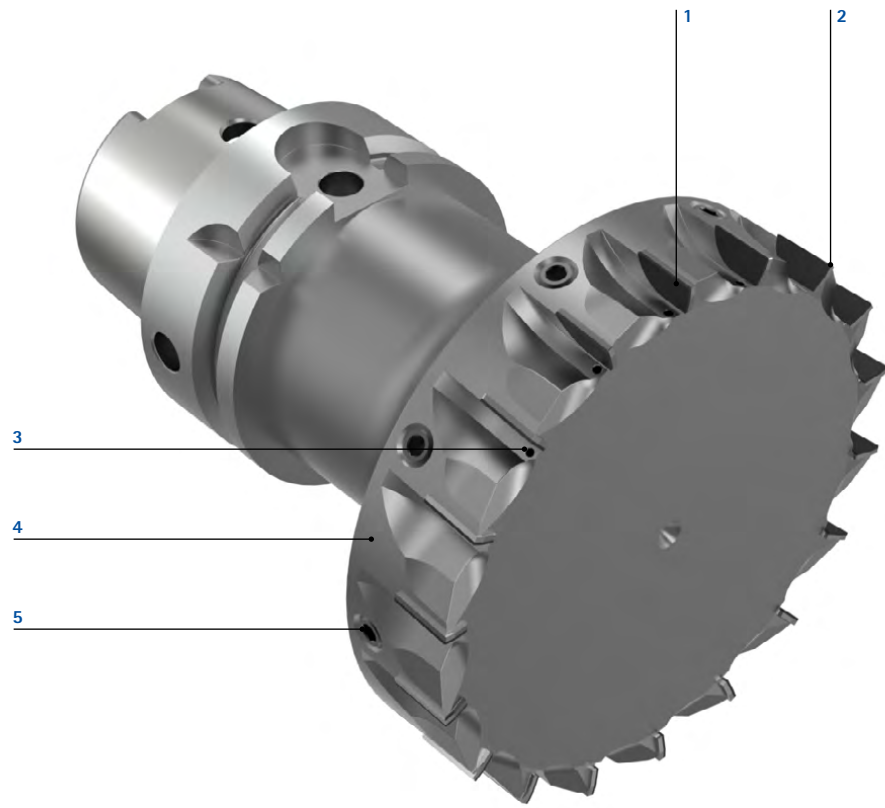

Largest number of cutting edges



- Highest symmetry and smooth running make extreme cutting speeds possible
- High feed rates possible and thus maximum productivity can be achieved

Direct coolant supply

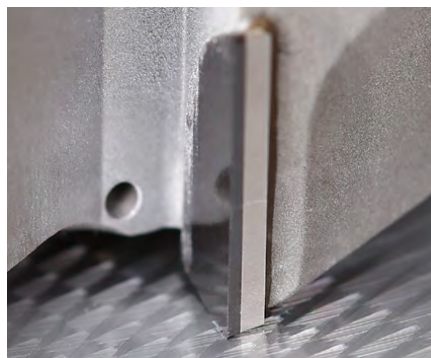

- Cooling directly at the cutting edge ensures improved chip removal
- Significantly reduced risk of chips coming between workpiece and tool

Modular construction



- Highest flexibility due to modularity and independence if there is machinery with different connections
- Especially for small series with different machinery
- Reduced noise level due to minimum cutting edge overhang and compact design

Highest number of teeth for more productivity in manufacturing.

FaceMill-Diamond

PCD face milling cutter with internal cooling
SHM581/591

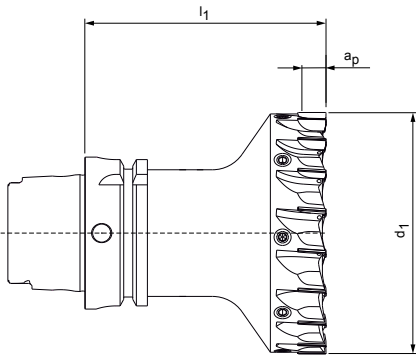

Design:

Diameter of milling cutter: 40.00 – 125.00 mm
Cutting material: PU611
Number of cutting edges: 10-22
Helix angle: 4°
Special features: Coolant outlets directly at the cutting edge

Application:

For face milling, especially with high stock removal. For cutting depths of up to 10 mm.



With tool body with HSK-A63 (hollow shank taper form A63) connection

Dimensions					Z _{eff}	a _p max.	Weight [kg]	Max. operating speed [min ⁻¹]	Specification*	Order number			
d ₁	d ₂	d ₃	d ₄	l ₁						SHM581 Rz ≤ 10		SHM591 Rz > 10	
									0.1x45°	R 0.4	0.1x45°	R 0.4	
40	-	-	-	100	10	10	1,42	33.000	[Series]-040BZ10R-[Form]A6-PU611	30981554	30981557	30981655	30981657
50	-	-	-	100	12	10	1,69	33.000	[Series]-050BZ12R-[Form]A6-PU611	30981568	30981570	30981667	30981669
63	-	-	-	100	14	10	1,97	33.000	[Series]-063BZ14R-[Form]A6-PU611	30981580	30981582	30981680	30981682
80	-	-	-	100	16	10	2,4	31.000	[Series]-080BZ16R-[Form]A6-PU611	30981602	30981605	30981692	30981694
100	-	-	-	100	18	10	3,01	28.000	[Series]-100BZ18R-[Form]A6-PU611	30981623	30981625	30981708	30981710
125	-	-	-	100	22	10	4,23	25.000	[Series]-125BZ22R-[Form]A6-PU611	30981639	30981641	30981724	30981726

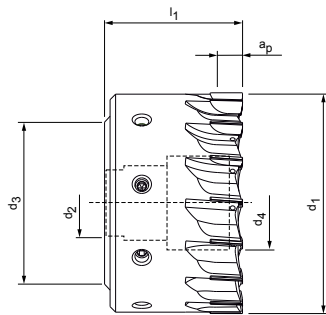

Milling cutter head

Dimensions					Z _{eff}	a _p max.	Weight [kg]	Max. operating speed [min ⁻¹]	Specification*	Order number			
d ₁	d ₂	d ₃	d ₄	l ₁						SHM581 Rz ≤ 10		SHM591 Rz > 10	
									0.1x45°	R 0.4	0.1x45°	R 0.4	
50	22	45	16	48	12	10	0,55	30.000	[Series]-050BZ12R-[Form]CA-PU611	30932481	30995680	30995698	30995700
63	22	48	26	48	14	10	0,91	30.000	[Series]-063BZ14R-[Form]CA-PU611	30995682	30995685	30995702	30995703
80	27	60	34	50	16	10	1,55	29.000	[Series]-080BZ16R-[Form]CA-PU611	30995687	30995688	30995705	30995707
100	32	78	43	50	18	10	2,49	27.000	[Series]-100BZ18R-[Form]CA-PU611	30932465	30995692	30995709	30995710
125	40	89	54	63	22	10	4,62	22.000	[Series]-125BZ22R-[Form]CA-PU611	30995694	30995696	30995712	30995714

Series

SHM581	SHM591
Surface quality Rz ≤ 10	Surface quality Rz > 10

Shape

F0010	R0040
Chamfer size 0.1x45°	Radius 0.4 mm

Example:

SHM581-050BZ12R-F0010CA-PU611

or

Example:

SHM591-050BZ12R-R0040CA-PU611

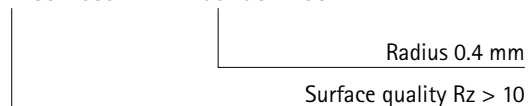
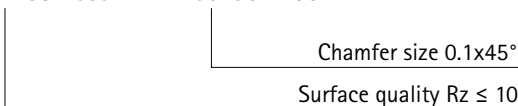

Tool body with other connection

Tool body with different connections in the dimensions of the connection HSK-A63 (hollow shank taper form A63) available at short notice.



HSK-100



SK40



BT40

Cutting edges with other geometries



Cutting edges with other geometries available at short notice:

- Radius: 0.1 - 1.5 mm
- Chamfer size: 0.1 - 0.9 mm

Custom tools made to order

Customised special designs are available on request.

- Individual dimensions
- Different numbers of teeth
- Insert position
- Different cutting materials
- Anticlockwise design

Accessories

	Milling cutter arbor for milling cutter head see MAPAL catalogue "CLAMPING"
-------------------------------------------------------------------------------------	-----------------------------------------------------------------------------

Spare parts**

	d ₁	Fastening screw with coolant delivery	Order no.
	50	SW8 - 20 Nm	30984018
	63	SW10 - 50 Nm	30984019
	80	SW12 - 80 Nm	30984030
	100	SW14 - 100 Nm	30984031
	125	SW14 - 200 Nm	30984032

Dimensions in mm.

* Specification plus required cutting edge design.

** Included in scope of delivery.

The maximum operating speeds refer only to the cutting edge system.

Cutting data recommendation for face milling cutters with PCD

Feed and cutting speed



MMG*	Workpiece material	Strength/hardness [N/mm ² - HRC]	NeoMill-Diamond-Power / NeoMill-Diamond-PowerBlue		NeoMill-Diamond-Eco						
			v _c [m/min]	f _z [mm]		v _c [m/min]	f _z [mm]				
				Cutting depth a _p max. 3 mm	Cutting depth a _p max. 5 mm			Cutting depth a _p max. 3 mm			
N	N1.1	Aluminium, non-alloy and alloy < 3 % Si	max. 6,000	to 0.2	0.1	max. 6,000	to 0.2				
	N1.2	Aluminium, alloy ≤ 7 % Si	max. 6,000			max. 6,000					
	N1.3	Aluminium, alloy > 7-12 % Si	max. 6,000			max. 6,000					
	N1.4	Aluminium, alloy > 12 % Si	max. 2,000			max. 2,000					
	N2.1	Copper, non-alloy and low-alloy	< 300			max. 6,000		max. 6,000			
	N2.2	Copper, alloy	> 300			max. 2,000		max. 2,000			
	N2.3	Brass, bronze, gunmetal	< 1200			max. 2,000		max. 2,000			
	N3.1	Graphite, > 8 μm				max. 2,000		max. 2,000			
	N4.1	Plastic, thermoplastics				max. 2,000		max. 2,000			
	N4.2	Plastic, thermosets				max. 2,000		max. 2,000			
	C	C1.1	Plastic matrix, aramide fibre-reinforced (AFRP)			max. 2,000		to 0.2	0.1	max. 2,000	to 0.2
		C1.2	Plastic matrix (thermosetting), CFRP/GFRP			max. 2,000				max. 2,000	
		C1.3	Plastic matrix (thermoplastic), CFRP/GFRP			max. 2,000				max. 2,000	
		C2.1	Carbon matrix, carbon fibre-reinforced (CFC)			max. 2,000				max. 2,000	
S	S1.1	Titanium, titanium alloys	< 400	150 - 500		150 - 500					
	S2.1	Titanium, titanium alloys	< 1200	150 - 500		150 - 500					
	S2.2	Titanium, titanium alloys	> 1200	150 - 500		150 - 500					
	S3.1	Nickel, non-alloy and alloy	< 900	150 - 500		150 - 500					
	S3.2	Nickel, non-alloy and alloy	> 900	150 - 500		150 - 500					
	S4.1	High-temperature super alloy Ni, Co and Fe-based		150 - 500		150 - 500					
S5.1	Tungsten and molybdenum alloys		150 - 500		150 - 500						

* MAPAL machining groups



SHOULDER MILLING CUTTER

Shoulder milling cutter with indexable inserts

NeoMill – radial technology	
NeoMill-2-Corner, AOKT12	292
NeoMill-4-Corner, ANMU12	294
NeoMill-4S-Corner, SDKT10	296
NeoMill-8-Corner, SNMU12	298
TGMill – tangential technology	
TGMill-2-Corner, CT_D09	300
TGMill-4-Corner, CT_Q09	302

Shoulder milling cutter with PCD

Face milling cutter with PCD combined with corner milling blade cartridge ..	258
------------------------------------------------------------------------------	-----

Accessories and spare parts

Shoulder milling cutter with indexable inserts	
Accessories for indexable inserts	384
Allocating milling cutter clamping screws	386

Technical appendix

Cutting data recommendations	306
Application notes facing and shoulder milling	398
Handling notes Milling cutter clamping screw	412

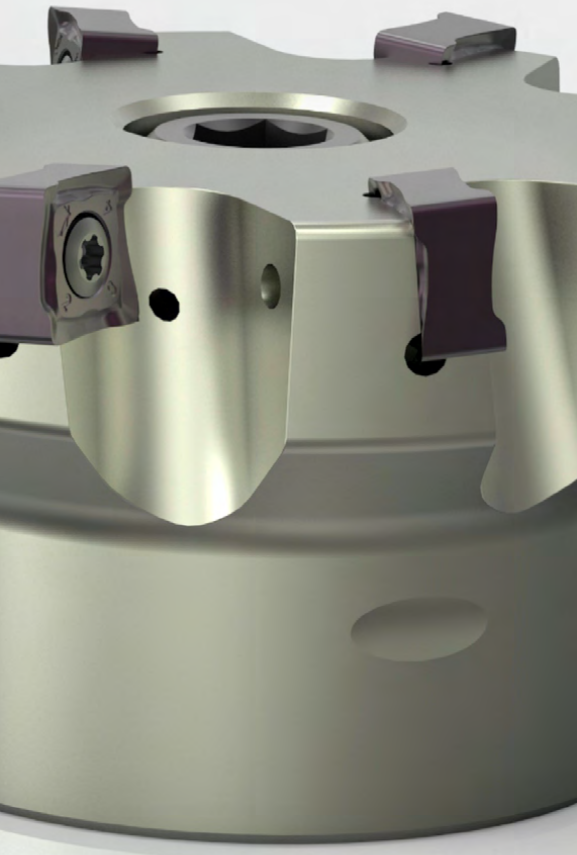

NeoMill®-2-Corner

Shoulder milling cutter, with radial technology
AOKT12

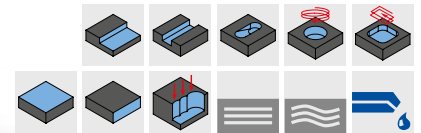
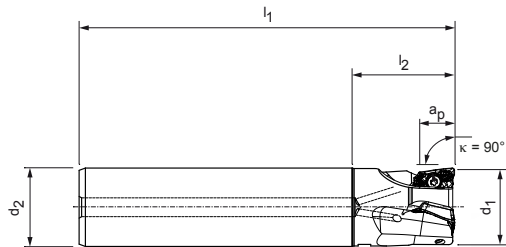

End milling cutter

Dimensions				Z _{eff}	a _p max.	Weight [kg]	Max. operating speed [min ⁻¹]	Cylindrical shank form	Internal cooling	Specification	Order no.
d ₁	d ₂	l ₁	l ₂								
20	20	110	30	2	11	0,2	55.000	HA	✓	ICM901-020-HA20-Z02R-AO_T12	31002166
20	20	81	30	2	11	0,2	55.000	HB	✓	ICM901-020-HB20-Z02R-AO_T12	31002167
25	25	120	32	3	11	0,4	49.000	HA	✓	ICM901-025-HA25-Z03R-AO_T12	31002168
25	25	88	32	3	11	0,3	49.000	HB	✓	ICM901-025-HB25-Z03R-AO_T12	31002169
32	32	130	40	4	11	0,7	43.000	HA	✓	ICM901-032-HA32-Z04R-AO_T12	31002170
32	32	100	40	4	11	0,5	43.000	HB	✓	ICM901-032-HB32-Z04R-AO_T12	31002171
40	32	150	88	5	11	0,9	39.000	HA	✓	ICM901-040-HA32-Z05R-AO_T12	31002174
40	32	110	48	5	11	0,7	39.000	HB	✓	ICM901-040-HB32-Z05R-AO_T12	31002175

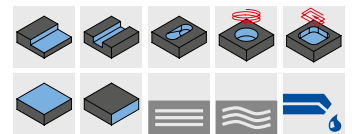
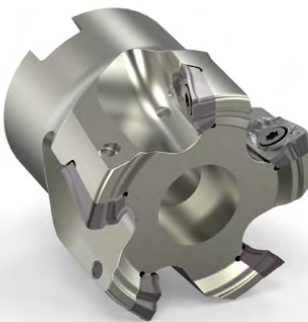
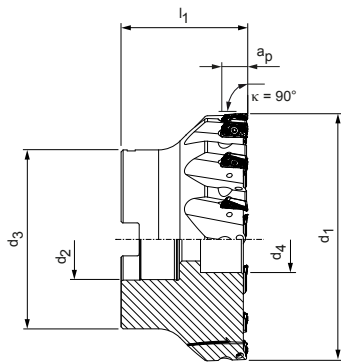

Milling cutter head

Dimensions					Z _{eff}	a _p max.	Weight [kg]	Max. operating speed [min ⁻¹]	Internal cooling	Specification	Order no.
d ₁	d ₂	d ₃	d ₄	l ₁							
40	16	32	14	40	5	11	0,2	39.000	✓	ICM901-040-CA16-Z05R-AO_T12	31002184
50	22	48	18,5	40	6	11	0,4	35.000	✓	ICM901-050-CA22-Z06R-AO_T12	31002185
63	22	48	18,5	40	8	11	0,6	31.000	✓	ICM901-063-CA22-Z08R-AO_T12	31002187

Dimensions in mm.

The maximum operating speeds refer only to the cutting edge system.

AOKT

Radial indexable insert, double edge

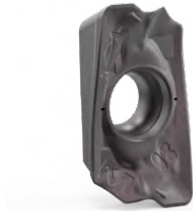

Workpiece material	P			M		K	
	Unalloyed Wear-resistant	Alloyed Tough/Ductile		Austenitic Wear-resistant	Ferritic Tough/Ductile		
Substrate	Carbide			Carbide		Carbide	
Coating	PVD		CVD	PVD		PVD	CVD
Cutting material type	HP975	HP980	HC775	HP980	HP985	HP975	HC770
Cutting edge design	M05	M03	M03	M03	M03	M05	M05
AOKT12	a_p max. [mm]						
AOKT12T304R-	*	31029366			31029367	31029366	31218303
AOKT12T308R-	*	31029368	31200903	31124557	31200903	31029369	31029368

Feed per tooth

Application	Medium machining				
	M03		M05		
Cutting edge design					
Coating	PVD	CVD	PVD	CVD	
Edge rounding	++	++	+++	+++	
Feed/tooth [mm]	P	0.08-0.25	0.08-0.19	0.1-0.25	0.1-0.19
	M	0.08-0.2			
	K			0.1-0.3	0.1-0.23
	N				

Legend: ++ = medium rounded | +++ = heavily rounded

Plunge angle

Diameter [mm]	Plunge angle [°]
20	6
25	4,2
32	3
40	2,2
50	1,7
63	1,3

Accessories

	AOKT12T3	Indexable inserts	Page 293
		Chuck for end milling cutter see MAPAL catalogue "CLAMPING"	
		Milling cutter arbor for milling cutter head see MAPAL catalogue "CLAMPING"	
		Milling cutter clamping screw for milling cutter head	Page 386

Spare parts**

	Clamping screw for indexable insert TORX®	Order no.
	End milling cutter	10105074
	Milling cutter head	10105075
	M3x6.5-TX8-IP	
	M3x7.5-TX8-IP	

* a_p max. depends on the type of milling cutter and application.

** Included in scope of delivery.

For cutting data recommendations, see end of chapter.

NeoMill®-4-Corner

Shoulder milling cutter, with radial technology
ANMU12

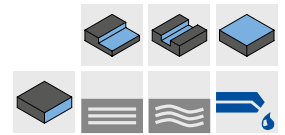
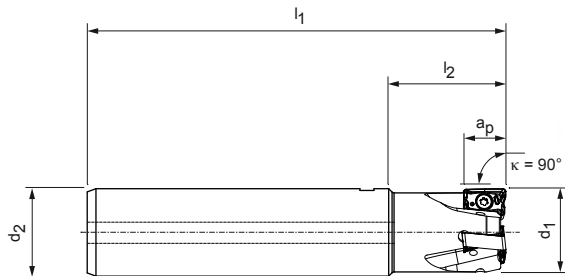

End milling cutter

Dimensions				Z _{eff}	a _p max.	Weight [kg]	Max. operating speed [min ⁻¹]	Cylindrical shank form	Internal cooling	Specification	Order no.
d ₁	d ₂	l ₁	l ₂								
25	25	120	32	3	10	0,41	42.000	HA	✓	ICM901-025-HA25-Z03R-AN_U12	31002200
25	25	88	32	3	10	0,29	42.000	HB	✓	ICM901-025-HB25-Z03R-AN_U12	31002201
32	32	130	40	4	10	0,74	31.500	HA	✓	ICM901-032-HA32-Z04R-AN_U12	31002202
32	32	100	40	4	10	0,55	31.500	HB	✓	ICM901-032-HB32-Z04R-AN_U12	31002203
40	32	150	50	5	10	0,98	25.000	HA	✓	ICM901-040-HA32-Z05R-AN_U12	31002206
40	32	110	50	5	10	0,73	25.000	HB	✓	ICM901-040-HB32-Z05R-AN_U12	31002207

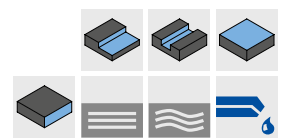
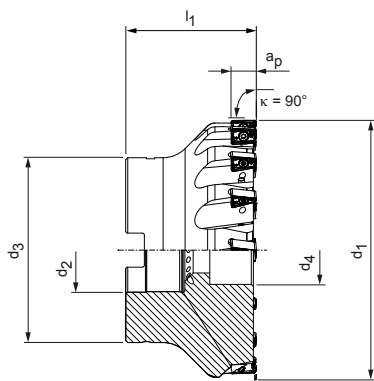

Milling cutter head, medium spacing

Dimensions					Z _{eff}	a _p max.	Weight [kg]	Max. operating speed [min ⁻¹]	Internal cooling	Specification	Order no.
d ₁	d ₂	d ₃	d ₄	l ₁							
50	22	48	18,5	40	6	10	0,4	23.000	✓	ICM901-050-CA22-Z06R-AN_U12	31018838
63	22	48	18,5	40	8	10	0,6	21.000	✓	ICM901-063-CA22-Z08R-AN_U12	31018870
80	27	60	20,5	50	10	10	1,2	18.000	✓	ICM901-080-CA27-Z10R-AN_U12	31018871
100	32	78	27,5	55	12	10	2,1	16.000	✓	ICM901-100-CA32-Z12R-AN_U12	31018872

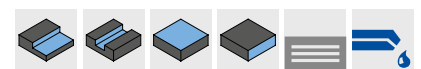

Milling cutter head, close spacing

Dimensions					Z _{eff}	a _p max.	Weight [kg]	Max. operating speed [min ⁻¹]	Internal cooling	Specification	Order no.
d ₁	d ₂	d ₃	d ₄	l ₁							
40	16	32	14	40	6	6	0,2	26.000	✓	ICM901-040-CA16-Z06R-AN_U12	31002214
50	22	48	18,5	40	8	6	0,5	23.000	✓	ICM901-050-CA22-Z08R-AN_U12	31002215
63	22	48	18,5	40	10	6	0,6	21.000	✓	ICM901-063-CA22-Z10R-AN_U12	31002217
80	27	60	20,5	50	12	6	1,2	18.000	✓	ICM901-080-CA27-Z12R-AN_U12	31002218

ANMU

Radial indexable insert, four cutting edges



Workpiece material	P			M		K			
	Unalloyed Wear-resistant	Alloyed Tough/Ductile		Austenitic Wear-resistant	Ferritic Tough/Ductile	GJL Wear-resistant	GJS Tough/Ductile	GJL Wear-resistant	GJS Tough/Ductile
Substrate	Carbide			Carbide		Carbide			
Coating	PVD		CVD	PVD		PVD		CVD	
Cutting material type	HP975	HP980	HC775	HP980	HP985	HP965	HP975	HC760	HC770
Cutting edge design	M05	M03	M03	M03	M03	M05	M05	M05	M05
ANMU12	a_p max. [mm]								
ANMU120504R-	*	31029427					31029427		31218310
ANMU120508R-	*	30968178	31027000	31124584	31027000	31029429	31029430	30968178	31124582 31124583
Cutting edge design	U05	U03	U03	U03	U03	U05	U05	U05	U05
ANMU12	a_p max. [mm]								
ANMU120508R-	*	31253944	31253948	31273152	31253948	31290794	31273129	31253944	31273153 31253947

Feed per tooth

Application	Cutting edge design	Medium machining				Difficult conditions			
		M03		M05		U03		U05	
Coating	Edge rounding	PVD	CVD	PVD	CVD	PVD	CVD	PVD	CVD
		++	++	+++	+++	++	++	+++	+++
Feed/tooth [mm]	P	0.08 - 0.25	0.08 - 0.19	0.1 - 0.25	0.1 - 0.19	0.08 - 0.25	0.08 - 0.19	0.1 - 0.25	0.1 - 0.19
	M	0.08 - 0.2	0.08 - 0.15			0.08 - 0.2	0.08 - 0.15		
	K			0.1 - 0.3	0.1 - 0.23			0.1 - 0.3	0.1 - 0.23
	N								

Legend: ++ = medium rounded | +++ = heavily rounded

Accessories

	ANMU1205	Indexable inserts	Page 295
		Chuck for end milling cutter see MAPAL catalogue "CLAMPING"	
		Milling cutter arbor for milling cutter head see MAPAL catalogue "CLAMPING"	
		Milling cutter clamping screw for milling cutter head	Page 386

Spare parts**

	ANMU1205	Clamping screw for indexable insert TORX® M3x8.5-TX8-IP	Order no. 10105076
--	----------	---------------------------------------------------------------	-----------------------

* a_p max. depends on the type of milling cutter and application.

** Included in scope of delivery.

The maximum operating speeds refer only to the cutting edge system.
For cutting data recommendations, see end of chapter.

NeoMill®-4S-Corner

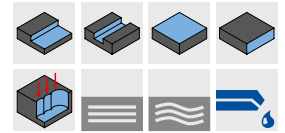
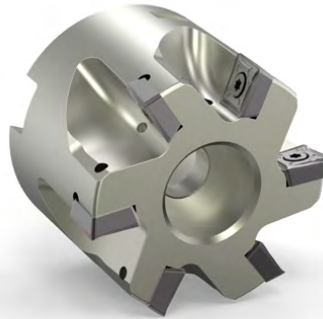
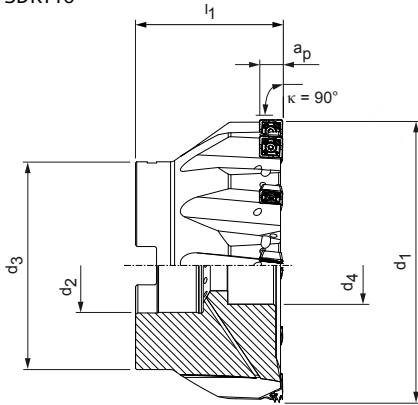

Shoulder milling cutter, with radial technology
SDKT10



Milling cutter head

Dimensions					Z _{eff}	a _p max.	Weight [kg]	Max. operating speed [min ⁻¹]	Internal cooling	Specification	Order no.
d ₁	d ₂	d ₃	d ₄	l ₁							
40	16	32	13,8	40	5	8	0,2	37.000	✓	ICM901-040-CA16-Z05R-SD_T10	31002262
50	22	48	18,5	40	6	8	0,4	33.000	✓	ICM901-050-CA22-Z06R-SD_T10	31002263
63	22	48	18,5	40	7	8	0,6	30.000	✓	ICM901-063-CA22-Z07R-SD_T10	31002264
80	27	60	20	50	9	8	1,1	26.000	✓	ICM901-080-CA27-Z09R-SD_T10	31002265
100	32	78	27	55	10	8	2,1	23.000	✓	ICM901-100-CA32-Z10R-SD_T10	31002266
125	40	89	33	63	12	8	3,5	21.000	✓	ICM901-125-CA40-Z12R-SD_T10	31002267
160	40	89	65	63	15	8	5	18.000	-	ICM900-160-CA40-Z15R-SD_T10	31002269

Accessories

	SDKT10T3	Indexable inserts	Page 297
		Milling cutter arbor for milling cutter head see MAPAL catalogue "CLAMPING"	
		Milling cutter clamping screw for milling cutter head	Page 386

Spare parts*

	SDKT10T3	Clamping screw for indexable insert TORX® M3x7.5-TX8-IP	Order no. 10105075
-------------------------------------------------------------------------------------	----------	---------------------------------------------------------	-----------------------

Dimensions in mm.

The maximum operating speeds refer only to the cutting edge system.

*Included in scope of delivery.

SDKT

Radial indexable insert, four cutting edges



Workpiece material	P				M			
	Unalloyed Wear-resistant	Alloyed Tough/Ductile	Unalloyed Wear-resistant	Alloyed Tough/Ductile	Austenitic Wear-resistant	Ferritic Tough/Ductile	Austenitic Wear-resistant	Ferritic Tough/Ductile
Substrate	Carbide				Carbide			
Coating	PVD		CVD		PVD			
Cutting material type	HP980		HC775		HP980		HP985	
Cutting edge design	M03		M03		M03		M03	
SDKT10	a_p max. [mm]							
SDKT10T308R-	*	31029463	31271444	31029463	31029463	31029463	31029465	31029465

Feed per tooth

Application		Medium machining	
Cutting edge design		M03	
Coating		PVD	CVD
Edge rounding		++	++
Feed/tooth [mm]	P	0.08 - 0.25	0.08 - 0.19
	M	0.08 - 0.2	0.08 - 0.15
	K		
	N		

Legend: ++ = medium rounded

* a_p max. depends on the type of milling cutter and application.
 For related clamping screw and screwdriver see page 384.
 For cutting data recommendations, see end of chapter.

NeoMill®-8-Corner

Shoulder milling cutter, with radial technology
SNMU12

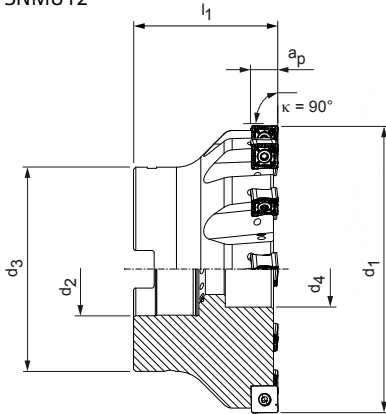

Milling cutter head, medium spacing

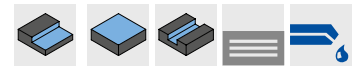

Dimensions					Z _{eff}	a _p max.	Weight [kg]	Max. operating speed [min ⁻¹]	Internal cooling	Specification	Order no.
d ₁	d ₂	d ₃	d ₄	l ₁							
50	22	48	18,5	40	4	8	0,4	17.000	✓	ICM901-050-CA22-Z04R-SN_U12	31002271
63	22	48	18,5	40	6	8	0,5	15.000	✓	ICM901-063-CA22-Z06R-SN_U12	31002272
80	27	60	20,5	50	8	8	1,2	13.000	✓	ICM901-080-CA27-Z08R-SN_U12	31002273
100	32	78	27,5	55	10	8	2,2	12.000	✓	ICM901-100-CA32-Z10R-SN_U12	31002274
125	40	89	33	63	12	8	3,7	11.000	✓	ICM901-125-CA40-Z12R-SN_U12	31002275
160	40	89	65	63	16	8	4,9	9.000	-	ICM900-160-CA40-Z16R-SN_U12	31002277
200	60	89	-	63	18	8	8,5	8.000	-	ICM900-200-CA60-Z18R-SN_U12	31002278



Milling cutter head, close spacing

50	22	48	18,5	40	6	6	0,4	17.000	✓	ICM901-050-CA22-Z06R-SN_U12	31002279
63	22	48	18,5	40	8	6	0,6	15.000	✓	ICM901-063-CA22-Z08R-SN_U12	31002280
80	27	60	20,5	50	10	6	1,1	13.000	✓	ICM901-080-CA27-Z10R-SN_U12	31002281
100	32	78	27,5	55	12	6	2,2	12.000	✓	ICM901-100-CA32-Z12R-SN_U12	31002282
125	40	89	33	63	14	6	3,6	11.000	✓	ICM901-125-CA40-Z14R-SN_U12	31002283
160	40	89	65	63	18	6	4,8	9.000	-	ICM900-160-CA40-Z18R-SN_U12	31002285

Accessories

	SNMU1205	Indexable inserts	Page 299
		Milling cutter arbor for milling cutter head see MAPAL catalogue "CLAMPING"	
		Milling cutter clamping screw for milling cutter head	Page 386

Spare parts*

	SNMU1205	Clamping screw for indexable insert TORX PLUS® M4x11-TX15-IP	Order no. 10018468
-------------------------------------------------------------------------------------	----------	--------------------------------------------------------------	-----------------------

Dimensions in mm.

The maximum operating speeds refer only to the cutting edge system.

* Included in scope of delivery.

SNMU

Radial indexable insert, eight cutting edges

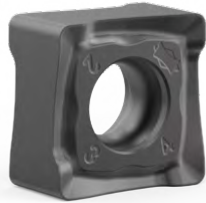

Workpiece material	P			M		K			
	Unalloyed Wear-resistant	Alloyed Tough/Ductile		Austenitic Wear-resistant	Ferritic Tough/Ductile	GJL Wear-resistant	GJS Tough/Ductile	GJL Wear-resistant	GJS Tough/Ductile
Substrate	Carbide			Carbide		Carbide			
Coating	PVD		CVD	PVD		PVD		CVD	
Cutting material type	HP975	HP980	HC775	HP980	HP985	HP965	HP975	HC760	HC770
Cutting edge design	M05	M03	M03	M03	M03	M05	M05	M05	M05
SNMU12	a_p max. [mm]								
SNMU120508R-	30968200	31029466	31124590	31029466	31029469	31029480	30968200	31124588	31124589
SNMU120512R-	31029482					31029483	31029482	31170977	31170976
SNMU120516R-	31175561						31175561		31218330
SNMU120520R-	31175564						31175564		31218332

Feed per tooth

Application		Medium machining			
Cutting edge design		M03		M05	
Coating		PVD	CVD	PVD	CVD
Edge rounding		++	++	+++	+++
Feed/tooth [mm]	P	0.08 - 0.25	0.08 - 0.19	0.1 - 0.25	0.1 - 0.19
	M	0.08 - 0.2	0.08 - 0.15		
	K			0.1 - 0.3	0.1 - 0.23
	N				

Legend: ++ = medium rounded | +++ = heavily rounded

* a_p max. depends on the type of milling cutter and application.
 For related clamping screw and screwdriver see page 384.
 For cutting data recommendations, see end of chapter.

TGMill-2-Corner

Shoulder milling cutter with tangential technology

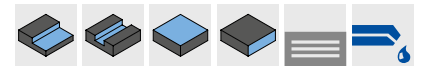
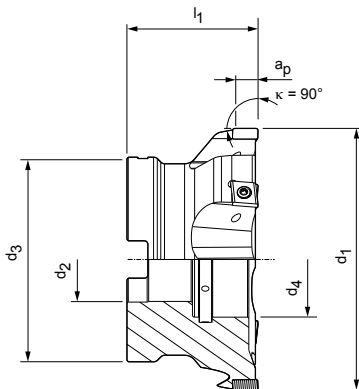

CT_D09



Milling cutter head, close spacing

Dimensions					Z _{eff}	a _p max.	Weight [kg]	Max. operating speed [min ⁻¹]	Internal cooling	Specification	Order no.
d ₁	d ₂	d ₃	d ₄	l ₁							
63	22	48	28	50	8	7	0,5	34.000	✓	ICM901-063-CA22-Z8R-CT_D09	30527703
80	27	60	38	50	12	7	1	30.200	✓	ICM901-080-CA27-Z12R-CT_D09	30527705
100	32	78	44	50	14	7	1,4	27.000	✓	ICM901-100-CA32-Z14R-CT_D09	30527706
125	40	89	56	63	18	7	2,6	24.100	✓	ICM901-125-CA40-Z18R-CT_D09	30527707
160	40	89	56	63	20	7	4	21.300	✓	ICM901-160-CA40-Z20R-CT_D09	30527708
200	60	140	-	63	25	7	8,1	19.100	✓	ICM901-200-CA60-Z25R-CT_D09	30527711

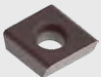
Accessories

	CT_D09T3	Indexable inserts	Page 301
		Milling cutter arbor for milling cutter head see MAPAL catalogue "CLAMPING"	
		Milling cutter clamping screw for milling cutter head	Page 386

Spare parts*

	CT_D09T3...	Clamping screw for indexable insert TORX PLUS® M3.5x9.4-TX10-IP	Order no. 10007315
-------------------------------------------------------------------------------------	-------------	-----------------------------------------------------------------	-----------------------

Dimensions in mm.

Further dimensions and designs in medium and wide spacing available upon request.

* Included in scope of delivery.

The maximum operating speeds refer only to the cutting edge system.

CTHD

Tangential indexable inserts, double edge

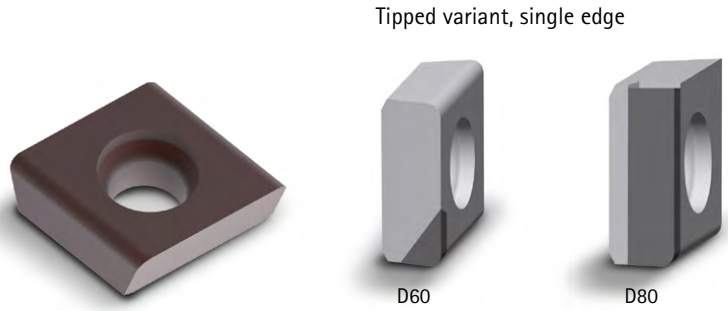

Workpiece material	N	
	Al alloyed ← Wear-resistant	Cu alloyed → Tough/Ductile
Substrate	Carbide	PCD
Coating	-	-
Cutting material type	HU616	PU617

Cutting edge design		D00		D80
CTHD09	a_p max. [mm]			
CTHD09T304...R-...	*	30029737		30492519
CTHD09T304...R90M018-...	*	30567180		31283626
CTHD09T308...R-...	*	30029738		30374036
CTHD09T312...R-...	*	30029739		

Cutting edge design			D60
CTHD09	a_p max. [mm]		
CTHD09T304...R-...	2.5		31283617
CTHD09T304...R90M018-...	2.5		31283618
CTHD09T308...R-...	2.5		31283621

Feed per tooth

Application		Universal application		
Cutting edge design		D00	D60	D80
Edge rounding		0	0	0
Feed/tooth [mm]	P			
	M			
	K			
	N	0.05 - 0.5	0.05 - 0.5	0.05 - 0.5

Legend: 0 = sharp edged

* a_p max. depends on the type of milling cutter and application.
 For related clamping screw and screwdriver see page 385.
 For cutting data recommendations, see end of chapter.

TGMill-4-Corner

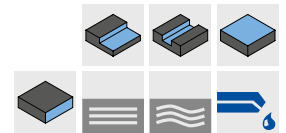
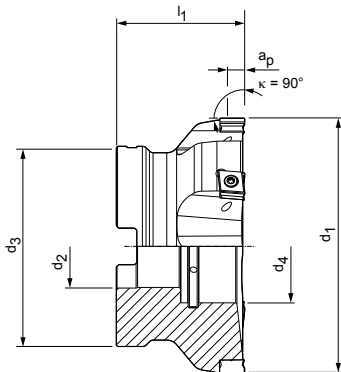

Shoulder milling cutter with tangential technology
CT_Q09



Milling cutter head, close spacing

Dimensions					Z _{eff}	a _p max.	Weight [kg]	Max. operating speed [min ⁻¹]	Internal cooling	Specification	Order no.
d ₁	d ₂	d ₃	d ₄	l ₁							
63	22	48	28	50	8	7	0,6	30.400	✓	ICM901-063-CA22-Z8R-CT_Q09	30527712
80	27	60	38	50	12	7	0,8	27.000	✓	ICM901-080-CA27-Z12R-CT_Q09	30527713
100	32	78	44	50	14	7	1,5	24.000	✓	ICM901-100-CA32-Z14R-CT_Q09	30527714
125	40	89	56	63	18	7	2,7	21.600	✓	ICM901-125-CA40-Z18R-CT_Q09	30527715
160	40	89	56	63	20	7	4,1	19.000	✓	ICM901-160-CA40-Z20R-CT_Q09	30527716
200	60	140	-	63	25	7	8,1	17.000	✓	ICM901-200-CA60-Z25R-CT_Q09	30527717

Accessories

	CT_Q0905	Indexable inserts	Page 304
		Milling cutter arbor for milling cutter head see MAPAL catalogue "CLAMPING"	
		Milling cutter clamping screw for milling cutter head	Page 386

Spare parts*

	CT_Q0905	Clamping screw for indexable insert TORX PLUS® M3.5x11-TX10-IP	Order no. 10105079
-------------------------------------------------------------------------------------	----------	----------------------------------------------------------------	-----------------------

Dimensions in mm.

Further dimensions and designs in medium and wide spacing available upon request.

* Included in scope of delivery.

The maximum operating speeds refer only to the cutting edge system.

CUSTOM-MADE FACE AND SHOULDER MILLING CUTTERS



In unstable machining situations or with large projection lengths, special milling cutters are designed with vibration dampers or vibration-damped connections are used to increase machining quality and tool life.

► Customised special solution upon request

CUSTOMISED SPECIAL SOLUTIONS

- Individual dimensions
- Different numbers of teeth
- Tool design with insert seats for tangential, radial and special cutting edges
- Milling cutter head or monolithic design with different connections
- Standard milling cutter arbor with vibration damper or customised tool body with integrated vibration damper

INSERTS IN SPECIAL DESIGN

- Special inserts with component-specific geometries and a large selection of cutting materials
- High process reliability in case of contour-dependent shapes and geometries
- Saves complex machining sequences, reducing cycle and non-productive times
- Multi-cutting-edge capability for manufacturing complex component-specific contours

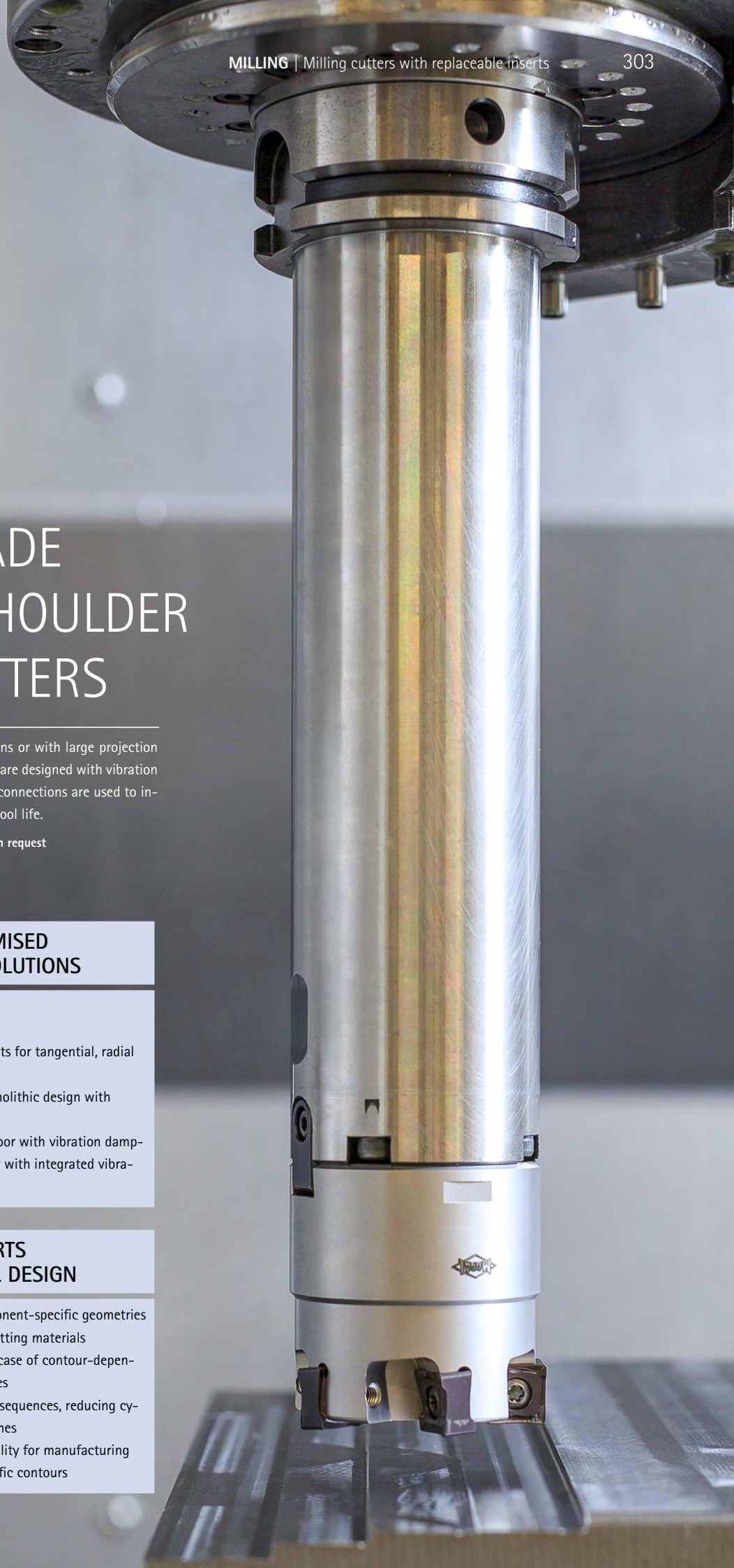

CTHQ | CTNQ

Tangential indexable inserts, four cutting edges

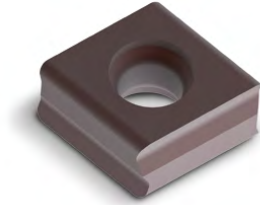

Workpiece material	P		M	
	Unalloyed Wear-resistant	Alloyed Tough/Ductile	Austenitic Wear-resistant	Ferritic Tough/Ductile
Substrate	Carbide		Carbide	
Coating	PVD		CVD	
Cutting material type	HP975		HP980, HP985	

Cutting edge design		H08		H06	H06	H06
CTNQ09	a_p max. [mm]					
CTNQ090508...R-...	*	31048496		31272737	31048497	31048498
CTNQ090512...R-...	*	31048510		31272700	31048511	31048512
CTHQ09						
CTHQ090508...R-...	*	31048522		31272841	31048523	31048524
CTHQ090512...R-...	*	31048526		31272850	31048527	31048528

Cutting edge design		A38	A36	A36	A36	A36
CTNQ09	a_p max. [mm]					
CTNQ090508...R-...	*	31048514		31272812	31048515	31048516
CTNQ090512...R-...	*	31048518		31272720	31048519	31048520
CTHQ09						
CTHQ090508...R-...	*	31048530		31272837	31048531	31048532
CTHQ090508...R90M008-...	*		31190731	31272835	31190733	
CTHQ090512...R-...	*	31048534		31272845	31048535	31048536

Feed per tooth

Application		Roughing					Medium machining				
		H06		H08		H21	A36		A38		H20
Cutting edge design		PVD	CVD	PVD	CVD	PVD	PVD	CVD	PVD	CVD	PVD
Coating											
Edge rounding		++		+++		+	++		+++		0
Feed/tooth [mm]	P	0.12-0.3	0.12-0.23	0.12-0.35	0.12-0.27		0.1-0.25	0.1-0.19	0.12-0.25	0.12-0.19	
	M	0.1-0.3	0.1-0.23				0.12-0.25	0.12-0.19			
	K			0.12-0.4	0.12-0.3				0.1-0.3	0.1-0.23	
	N					0.15 - 0.35					0.1 - 0.3

Legend: 0 = sharp edged | + = slightly rounded | ++ = medium rounded | +++ = heavily rounded

* a_p max. depends on the type of milling cutter and application.
 For related clamping screw and screwdriver see page 385.
 For cutting data recommendations, see end of chapter.

K						N	
GJL ← Wear-resistant		GJS → Tough/Ductile		GJL ← Wear-resistant		GJS → Tough/Ductile	
PVD				Carbide		Carbide	
HP965		HP975		CVD		-	PVD
H08				H08		HU616	HP615
31048495	31048496	31272745		31272748			
31048499	31048510	31272705		31272707			
31048521	31048522	31272843		31272844			31257300
31048525	31048526	31272851		31272855			31316852
A38		A38		A36		H20	
31048513	31048514	31272816		31272817			
31048517	31048518	31272725		31272726			
31048529	31048530	31272838		31272840		31316862	
			31272832		31272834	31316865	
31048533	31048534	31272847		31272848		31316863	

Cutting data recommendations for shoulder milling cutters

Cutting speed

Shoulder milling cutter

MMG*		Workpiece material	Strength/hardness [N/mm ²] [HRC]	Cooling			
				MQL/Air	Dry	Coolant	
P	P1	P1.1 Structural, free-cutting, case hardened and heat-treated steels, non-alloy	< 700		✓		
		P1.2 Structural, free-cutting, case hardened and heat-treated steels, non-alloy	< 1200		✓		
	P2	P2.1 Nitrided, case hardened and heat-treated steels, alloy	< 900		✓		
		P2.2 Nitrided, case hardened and heat-treated steels, alloy	< 1400		✓		
	P3	P3.1 Tool, bearing, spring and high-speed steels**	< 800		✓		
		P3.2 Tool, bearing, spring and high-speed steels**	< 1000		✓		
		P3.3 Tool, bearing, spring and high-speed steels**	< 1500		✓		
	P4	P4.1 Stainless steels, ferritic and martensitic					
	P5	P5.1 Cast steel					
	P6	P6.1 Stainless cast steel, ferritic and martensitic					
M	M1	M1.1 Stainless steels, austenitic	< 700		✓		
		M1.2 Stainless steels, ferritic/austenitic (duplex)	< 1000				
	M2	M2.1 Stainless/heat-resistant cast steel, austenitic	< 700				
	M3	M3.1 Stainless cast steel, ferritic/austenitic (duplex)	< 1000				
K	K1	K1.1 Cast iron with lamellar graphite (grey cast iron), GJL	< 300		✓		
		K2.1 Cast iron with spheroidal graphite, GJS	< 500		✓		
	K2	K2.2 Cast iron with spheroidal graphite, GJS	500-800				
		K2.3 Cast iron with spheroidal graphite, GJS	> 800				
	K3	K3.1 Cast iron with spheroidal graphite, GJV; malleable cast iron, GJM	< 500				
		K3.2 Cast iron with spheroidal graphite, GJV; malleable cast iron, GJM	> 500				
N	N1	N1.1 Aluminium, non-alloy and alloy < 3 % Si				✓	
		N1.2 Aluminium, alloy ≤ 7 % Si				✓	
		N1.3 Aluminium, alloy > 7-12 % Si				✓	
		N1.4 Aluminium, alloy > 12 % Si				✓	
	N2	N2.1 Copper, non-alloy and low-alloy	< 300				✓
		N2.2 Copper, alloy	> 300				✓
		N2.3 Brass, bronze, gunmetal	< 1200				✓
	N3	N3.1 Graphite, > 8 µm					✓
		N3.2 Graphite, ≤ 8 µm					✓
	N4	N4.1 Plastic, thermoplastics					✓
		N4.2 Plastic, thermosets					✓
N4.3 Plastic, foams						✓	

* MAPAL machining groups

** If the alloy parts Cr, Mo, Ni, V, W in total > 8%, then select the next highest MAPAL machining group.

v _c [m/min] according to cutting material type and contact ratio a _e /D																			
Carbide PVD-coated										Carbide CVD-coated						Carbide - uncoated		PVD	
HP615		HP965		HP975		HP980		HP985		HC760		HC770		HC775		HU616		PU617	
> 0.6	< 0.6	> 0.6	< 0.6	> 0.6	< 0.6	> 0.6	< 0.6	> 0.6	< 0.6	> 0.6	< 0.6	> 0.6	< 0.6	> 0.6	< 0.6	> 0.6	< 0.6	> 0.6	< 0.6
				180	220	180	220					260	280						
				150	180	150	180					250	270	240	260				
				160	200	160	200					240	260	230	250				
						130	160							220	240				
						130	160												
						130	160												
						120	150												
						120	150												
						130	160												
						110	140												
						160	180	140	170										
						140	160	120	150										
								100	120										
								90	110										
		220	270	200	240					330	350	320	330						
		200	240	180	220					300	330	300	320						
		180	220	160	200							260	300						
		160	200	140	170							220	260						
		170	210	150	180					210	240	200	220						
		160	200	140	170					200	220	180	200						
700	700															500	500	2000	2000
400	480															300	360	1500	1800
300	360															230	280	1200	1440
270	330																	700	840
250	300															250	300	600	720
130	160															120	150	500	600
190	230															180	220	450	540
320	390															300	360		
320	390																		
220	270															300	360	500	600
210	260															250	300	400	480

The specified machining values are guide values.
 The optimum data for the respective machining task should be determined during the test or machining.



HIGH-FEED MILLING CUTTER

NeoMill – radial technology

NeoMill-2-HiFeed90, LP__06 _____	310
NeoMill-2-HiFeed90, LD__10 _____	312
NeoMill-2-HiFeed90, LD__18 _____	314
NeoMill-4-HiFeed90, SD__06 _____	320
NeoMill-4-HiFeed90, SD__10 _____	322
NeoMill-4-HiFeed90, SD__14 _____	324
NeoMill-4-HiFeed90, SD__18 _____	325

Accessories and spare parts

Accessories for indexable inserts _____	384
Allocating milling cutter clamping screws _____	386

Technical appendix

Cutting data recommendations _____	330
Handling notes Milling cutter clamping screw _____	412

NeoMill®-2-HiFeed90

High-feed and 90° shoulder milling cutter
LP_06



End milling cutter

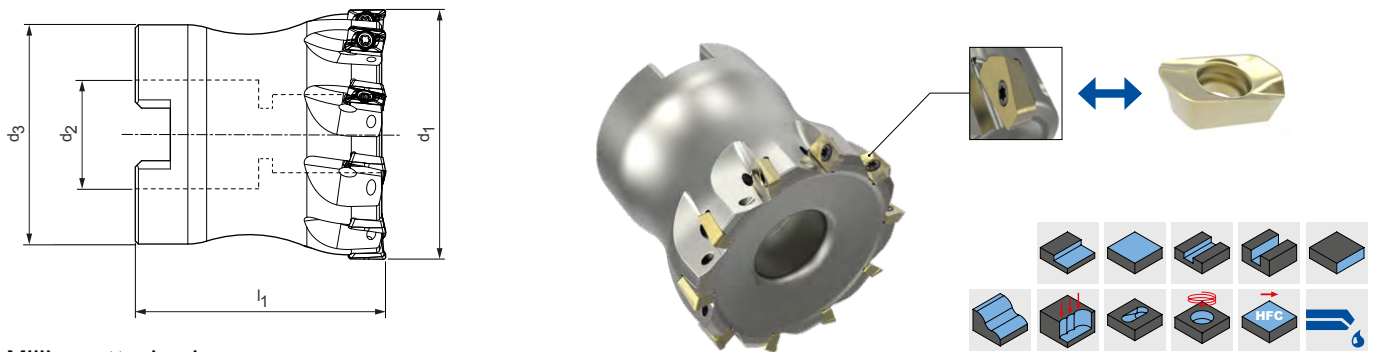

Dimensions				Z _{eff}	a _p max.		Weight [kg]	Internal cooling	Specification	Order no.
d ₁	d ₂	l ₁	l ₂		90°	HFC				
10	10	80	28	2	5,2	0,7	0,04	✓	IMH901-010-080-HA10-Z2R-LP_06	31146637
12	12	80	30	3	5,2	0,7	0,06	✓	IMH901-012-080-HA12-Z3R-LP_06	31146638
16	16	85	35	4	5,2	0,7	0,11	✓	IMH901-016-085-HB16-Z4R-LP_06	31146639
20	20	90	40	5	5,2	0,7	0,18	✓	IMH901-020-090-HB20-Z5R-LP_06	31146640
25	25	106	50	7	5,2	0,7	0,34	✓	IMH901-025-106-HB25-Z7R-LP_06	31146641



Milling cutter head

Dimensions				Z _{eff}	a _p max.		Weight [kg]	Internal cooling	Specification	Order no.
d ₁	d ₂	d ₃	l ₁		90°	HFC				
32	16	25	40	8	5,2	0,7	0,11	✓	IMH901-032-CA16-Z08R-LP_06	31146643
40	16	35	40	10	5,2	0,7	0,23	✓	IMH901-040-CA16-Z10R-LP_06	31146644
50	22	43	40	11	5,2	0,7	0,35	✓	IMH901-050-CA22-Z11R-LP_06	31146645

Accessories

	LP__0602	Indexable insert 90°	Page 318
	LP__0602	Indexable insert HFC	Page 316
		Milling cutter arbor for milling cutter head see MAPAL catalogue "CLAMPING"	
		Milling cutter clamping screw for milling cutter head	Page 386
		Chuck for end milling cutter see MAPAL catalogue "CLAMPING"	

Spare parts*

	LP__0602	Clamping screw for indexable insert M1.8X4.09-TX6-IP	Order no.
			31164571

CAM programming note

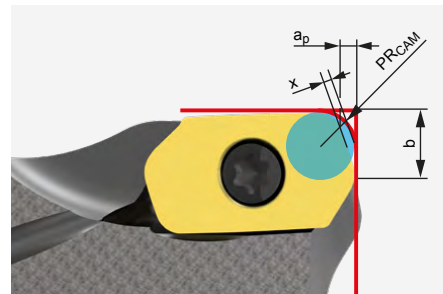

When using an HFC indexable insert, the programme radius PR_{CAM} must be observed.

LP__06

Dimensions [mm]			
PR_{CAM}	a_p	x	b
1,2	0,7	0,2	1,4

*Included in scope of delivery.

NeoMill®-2-HiFeed90

High-feed and 90° shoulder milling cutter
LD__10



End milling cutter

Dimensions				Z _{eff}	a _p max.		Weight [kg]	Internal cooling	Specification	Order no.
d ₁	d ₂	l ₁	l ₂		90°	HFC				
16	16	85	37	2	9	1,4	0,10	✓	IMH901-016-085-HB16-Z2R-LD__10	31144149*
20	20	90	40	2	9	1,4	0,17	✓	IMH901-020-090-HB20-Z2R-LD__10	31144159*
20	20	90	40	3	9	1,4	0,17	✓	IMH901-020-090-HB20-Z3R-LD__10	31144151
25	25	106	50	3	9	1,4	0,32	✓	IMH901-025-106-HB25-Z3R-LD__10	31144152
25	25	106	50	4	9	1,4	0,32	✓	IMH901-025-106-HB25-Z4R-LD__10	31144153
32	32	124	64	3	9	1,4	0,65	✓	IMH901-032-124-HB32-Z3R-LD__10	31144154
32	32	124	64	5	9	1,4	0,64	✓	IMH901-032-124-HB32-Z5R-LD__10	31144155

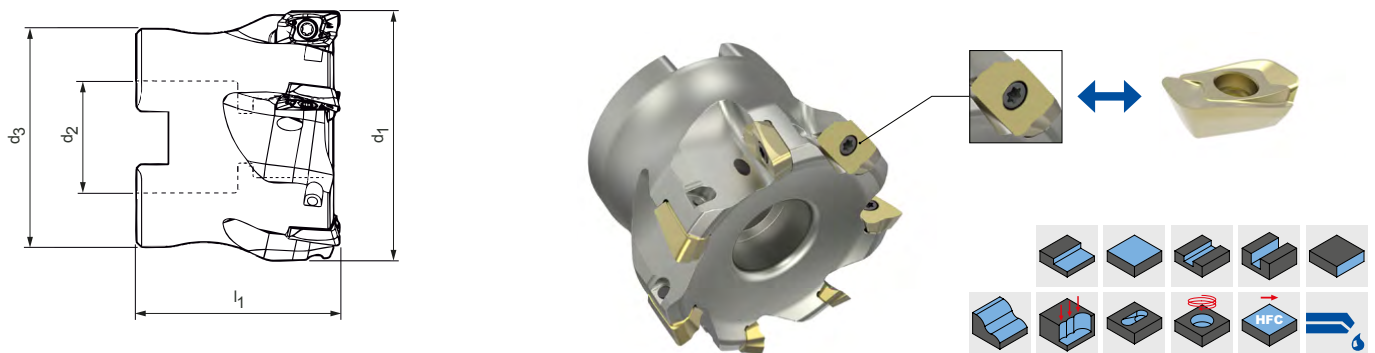





Milling cutter head

Dimensions				Z _{eff}	a _p max.		Weight [kg]	Internal cooling	Specification	Order no.
d ₁	d ₂	d ₃	l ₁		90°	HFC				
40	16	35	40	4	9	1,4	0,19	✓	IMH901-040-CA16-Z04R-LD__10	31144049
40	16	35	40	6	9	1,4	0,19	✓	IMH901-040-CA16-Z06R-LD__10	31144050
50	22	43	40	5	9	1,4	0,29	✓	IMH901-050-CA22-Z05R-LD__10	31144051
50	22	43	40	7	9	1,4	0,29	✓	IMH901-050-CA22-Z07R-LD__10	31144052
63	22	48	40	6	9	1,4	0,48	✓	IMH901-063-CA22-Z06R-LD__10	31144053
63	22	48	40	8	9	1,4	0,46	✓	IMH901-063-CA22-Z08R-LD__10	31144054
80	27	60	50	10	9	1,4	0,92	✓	IMH901-080-CA27-Z10R-LD__10	31144055

Dimensions in mm.

* Use with clamping screw M2.5X5.9

Accessories

	LD__1004	Indexable insert 90°	Page 318
	LD__1004	Indexable insert HFC	Page 316
		Milling cutter arbor for milling cutter head see MAPAL catalogue "CLAMPING"	
		Milling cutter clamping screw for milling cutter head	Page 386
		Chuck for end milling cutter see MAPAL catalogue "CLAMPING"	

Spare parts**

		Clamping screw for indexable insert	Order no.
	***	M2.5X5.9-TX8-IP	31161842
	LD__1004	M2.5X6.8-TX8-IP	31161843

CAM programming note

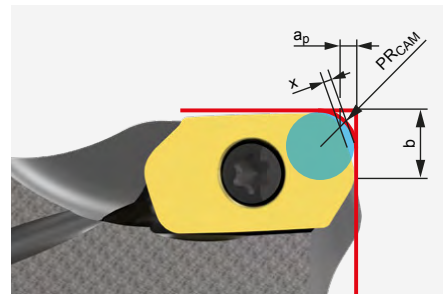

When using an HFC indexable insert, the programme radius PR_{CAM} must be observed.

LD__10

Dimensions [mm]			
PR_{CAM}	a_p	x	b
2,2	1,4	0,4	3,52

** Included in scope of delivery.

*** Use the order numbers marked with *.

NeoMill®-2-HiFeed90

90° shoulder milling cutter

LD__18

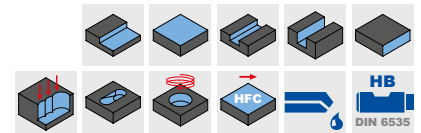
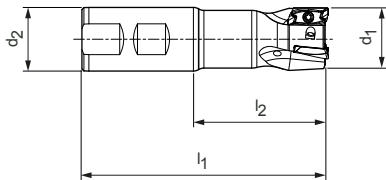

End milling cutter



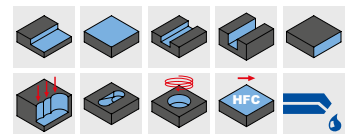
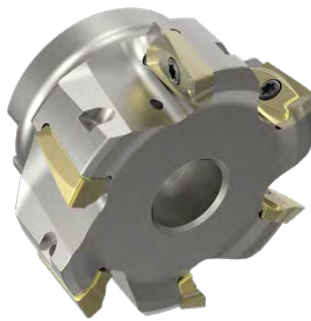
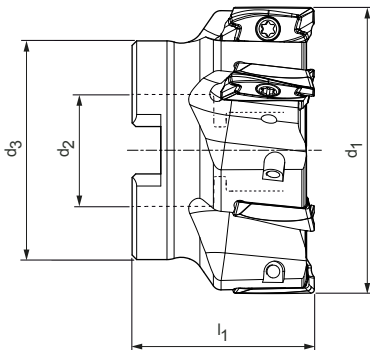

Dimensions				Z_{eff}	a_p max.	Weight [kg]	Internal cooling	Specification	Order no.
d_1	d_2	l_1	l_2						
25	25	106	50	2	17	0,30	✓	IMH901-025-106-HB25-Z2R-LD__18	31144161
32	32	124	64	3	17	0,61	✓	IMH901-032-124-HB32-Z3R-LD__18	31144162
40	32	124	65	4	17	0,70	✓	IMH901-040-130-HB32-Z4R-LD__18	31144163



Milling cutter head

Dimensions				Z_{eff}	a_p max.	Weight [kg]	Internal cooling	Specification	Order no.
d_1	d_2	d_3	l_1						
40	16	35	40	4	17	0,16	✓	IMH901-040-CA16-Z04R-LD__18	31144077
50	22	43	40	5	17	0,27	✓	IMH901-050-CA22-Z05R-LD__18	31144074
52	22	43	40	5	17	0,28	✓	IMH901-052-CA22-Z05R-LD__18	31144078
63	22	48	40	5	17	0,43	✓	IMH901-063-CA22-Z05R-LD__18	31144079
66	22	48	40	6	17	0,51	✓	IMH901-066-CA22-Z06R-LD__18	31144080
80	27	60	50	7	17	0,85	✓	IMH901-080-CA27-Z07R-LD__18	31144081
100	32	78	50	8	17	1,49	✓	IMH901-100-CA32-Z08R-LD__18	31144082
125	40	90	60	9	17	2,79	✓	IMH901-125-CA40-Z09R-LD__18	31144083
160	40	115	60	10	17	3,65	-	IMH900-160-CA40-Z10R-LD__18	31144084

Accessories

	LD__1805	Indexable insert 90°	Page 318
		Milling cutter arbor for milling cutter head see MAPAL catalogue "CLAMPING"	
		Milling cutter clamping screw for milling cutter head	Page 386
		Chuck for end milling cutter see MAPAL catalogue "CLAMPING"	

Spare parts*

	LD__1805	Clamping screw for indexable insert M3.5X10-TX15-IP	Order no. 30870699
-----------------------------------------------------------------------------------	----------	-----------------------------------------------------------	-----------------------

* Included in scope of delivery.

LPMX – LDMX

Radial indexable insert, double edge



For high-feed machining

		Carbide							
Workpiece material	P	Unalloyed		Alloyed		M	Austenitic		Ferritic
		← Wear-resistant	→ Tough/Ductile	← Wear-resistant	→ Tough/Ductile		← Wear-resistant	→ Tough/Ductile	
Coating		PVD		CVD			PVD		
Cutting material type		HP635	HP640	HC530	HC535	HP650	HP655		
Cutting edge design		PMS	PMS	PMS		MQL	MQL		
LPMX		a_p max. [mm]							
LPMX060210R-	0.7 *	31146693		31146692		31146694			
Cutting edge design		PMS	PMS	PMS	PMS	MQL	MQL		
LDMX		a_p max. [mm]							
LDMX100415R-	1.4 *	31144267	31144268	31144265	31144266	31144263	31144264		

Feed per tooth (selection according to cutting edge design)

* MMG	Cutting edge design	LP__06							LD__10						
		KV	a _p max. [mm]			f _z [mm]			KV	a _p max. [mm]			f _z [mm]		
P	PMS	-	0.2	0.4	0.7	0.2	0.5	0.8	Δ+	0.4	0.9	1.4	0.6	1	1.5
M	MQL	-	0.2	0.4	0.7	0.2	0.4	0.7	Δ+	0.4	0.9	1.4	0.5	0.9	1.3
K	KMS								Δ+	0.4	0.9	1.4	0.6	1.2	1.5
H	HMS	-	0.4	0.4	0.7	0.2	0.5	0.8	Δ+	0.4	0.9	1.4	0.6	1.2	1.5

Legend: KV = edge rounding | - = not specified | Δ+ = bevelled and slightly rounded

* a_p max. depends on the type of milling cutter and application.

** MAPAL machining groups

Carbide			
K		H	
PVD	CVD	PVD	CVD
HP630	HC525	HP320	HC220
		HMS	HMS
		31146696	31146695
KMS	KMS	HMS	HMS
31144262	31144261	31146721	31146723

Dimensions [mm]				
l	d	s	d ₁	R
0,7	3,64	2,15	2,05	1
1,5	6,6	4,76	2,8	1,5

Plunge angle | High-feed machining

Diameter [mm]	Plunge angle [°]	
	LP_06	LD_10
10	6.3	-
12	4.5	-
16	3.5	8.8
18	3	-
20	1.8	6.1
25	1.5	4.4
32	1.1	3.2
40	0.8	2.4
50	0.6	1.9
63	-	1.4
80	-	1.1

CAM programming note

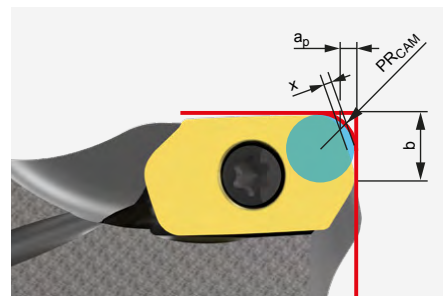

When using an HFC indexable insert, the programme radius PR_{CAM} must be observed.

Dimensions [mm]				
	PR_{CAM}	a_p	x	b
LP_06	1,2	0,7	0,2	1,4
LD_10	2,2	1,4	0,4	3,52

LPMX – LDGX – LDMX – LDHX

Radial indexable insert, double edge



For 90° machining

		Carbide					
Workpiece material	P	Alloyed					
		Unalloyed			Alloyed		
Coating		PVD					
Cutting material type		HP635		HP640		HP645	
Cutting edge design		PMU		PMU			
LPMX		a_p max. [mm]					
LPMX060204R-		5.2 *	31146697	31146698			
Cutting edge design							
LDGX		a_p max. [mm]					
LDGX180508R-		17 *					
Cutting edge design		PMU	PRU	PMU	PRU	PMU	PRU
LDMX		a_p max. [mm]					
LDMX100404R-		9 *	31146722	31146724			
LDMX100408R-		9 *	31144258	31144259		31144260	
LDMX100420R-		9 *	31144269	31144270			
LDMX100430R-		9 *	31144271	31144272			
LDMX180508R-		17 *	31144276	31144277		31144278	
LDMX180512R-		17 *		31144280	31144281		31144282
LDMX180516R-		17 *		31146720	31146719		
Cutting edge design							
LDHX		a_p max. [mm]					
LDHX100404R-		9 *					
LDHX100408R-		9 *					

Feed per tooth (selection according to cutting edge design)

* MMG	Cutting edge design	LP_06					LD_10					LD_18										
		KV	a _p max. [mm]		f _z [mm]		KV	a _p max. [mm]		f _z [mm]		KV	a _p max. [mm]		f _z [mm]							
P	PMU	-	0.5	2	5.2	0.1	0.13	0.17	Δ+	1	3	9	0.1	0.18	0.25	Δ+	1	6	17	0.1	0.19	0.25
	PRU								Δ+	1	6	17	0.15	0.22	0.8							
M	MMU	-	0.5	2	5.2	0.08	0.1	0.15	Δ+	1	3	9	0.1	0.15	0.2	Δ+	1	6	17	0.1	0.15	0.22
K	KMU								Δ+	1	3	9	0.15	0.2	0.27	Δ+	1	6	17	0.15	0.21	0.26
	KRU								Δ+	1	6	17	0.15	0.24	0.3							
N	NMU								0	1	3	9	0.1	0.14	0.26	0	1	6	17	0.1	0.14	0.26

Legend: KV = edge rounding | - = not specified | 0 = sharp edged | Δ+ = bevelled and slightly rounded

* a_p max. depends on the type of milling cutter and application.

** MAPAL machining groups

Carbide					
M		K		N	
Austenitic	Ferritic	GJL	GJS		
← Wear-resistant	→ Tough/Ductile	← Wear-resistant	→ Tough/Ductile		
PVD		PVD		Uncoated	PVD
HP650	HP655	HP630		HU110	HP110
MMU					
31146699					
				NMU	NMU
				31144411	31144254
MMU	MMU	KMU	KRU		
31146690	31146691				
31144256	31144257	31144255			
31144274	31144275	31144273			
31146715	31146717		31144279		
31146716	31146718				
				NMU	NMU
				31144409	31144252
				31144410	31144253

Dimensions [mm]				
l	d	s	d ₁	R
6	3,64	2,15	2,05	0,4
18	9,65	5	4,15	0,8
10	6,6	4,76	2,8	0,4
10	6,6	4,76	2,8	0,8
10	6,6	4,76	2,8	2
10	6,6	4,76	2,8	3
18	9,65	5	4,15	0,8
18	9,65	5	4,15	1,2
18	9,65	5	4,15	1,6
10	6,6	4,76	2,8	0,4
10	6,6	4,76	2,8	0,8

Plunge angle | 90° machining

Diameter [mm]	Plunge angle [°]		
	LP_06	LD_10	LD_18
10	8.4	-	-
12	6.3	-	-
16	5	18	-
18	3.5	-	-
20	2.3	12.2	-
25	1.8	8.7	-
32	1.3	6.2	-
40	1	4.6	5
50	0.8	3.5	4
52	-	-	3.8
63	-	2.7	3.18
66	-	-	2.9
80	-	2.1	2.51
100	-	-	2
125	-	-	1.6
160	-	-	1.25

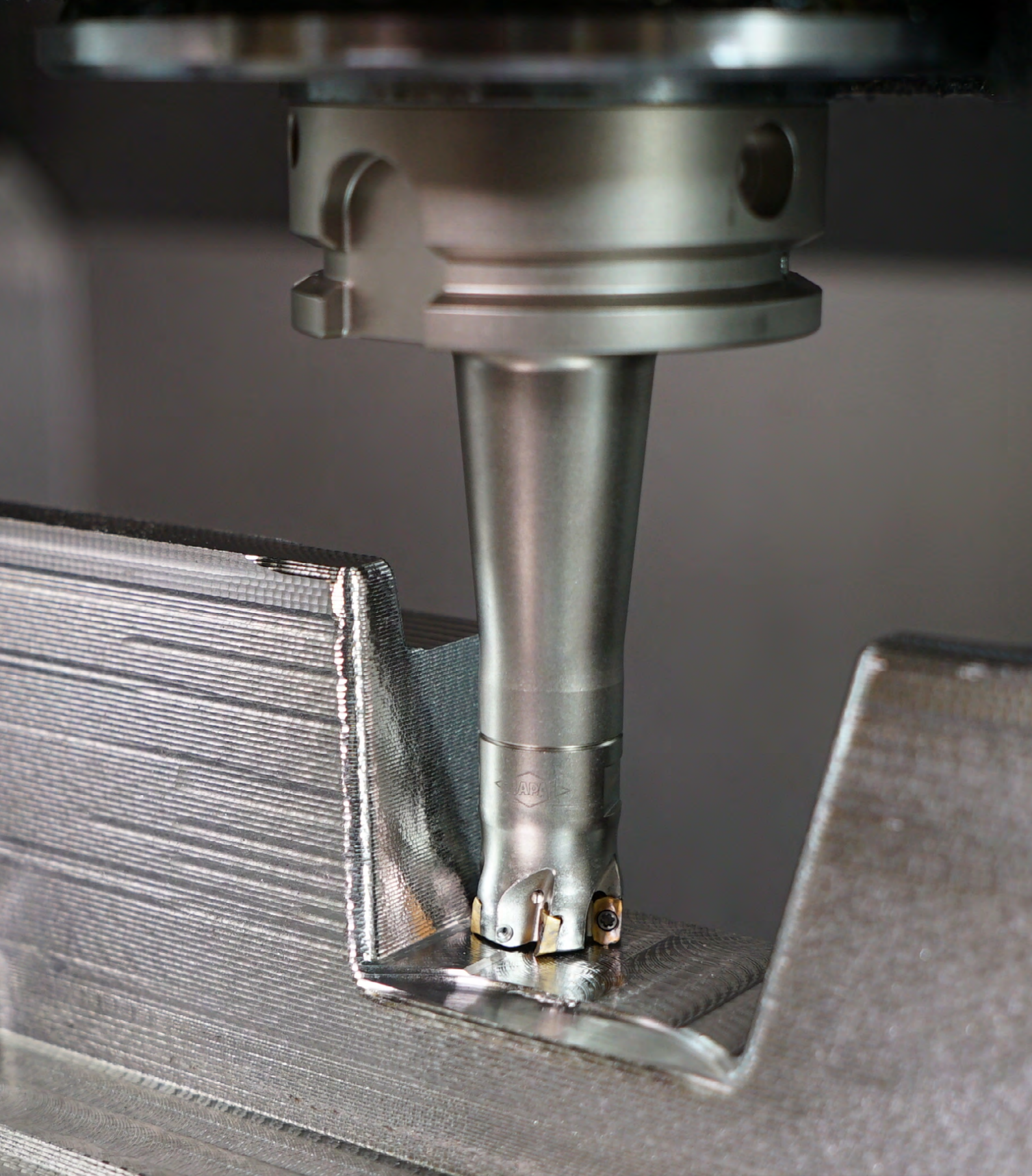

Screw-in milling cutters and other products for Die & Mould sector you will find under: die-mould.mapal.com

NeoMill®-4-HiFeed90

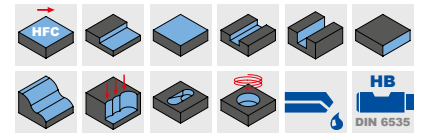
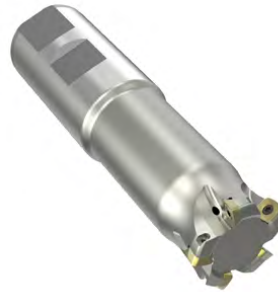
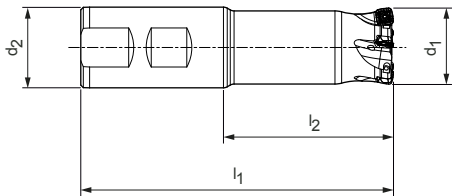

High-feed milling cutter
SD__06



End milling cutter

Dimensions				Z_{eff}	a_p max.	Weight [kg]	Internal cooling	Specification	Order no.
d_1	d_2	l_1	l_2						
16	16	85	37	2	1	0,10	✓	IMH901-016-085-HB16-Z2R-SD__06	31146632
20	20	90	40	3	1	0,17	✓	IMH901-020-090-HB20-Z3R-SD__06	31146633
25	25	106	50	4	1	0,33	✓	IMH901-025-106-HB25-Z4R-SD__06	31146634
32	32	124	64	5	1	0,66	✓	IMH901-032-124-HB32-Z5R-SD__06	31146635
35	32	124	64	5	1	0,67	✓	IMH901-035-124-HB32-Z5R-SD__06	31146636

Accessories

	SD__0602	Indexable insert HFC	Page 326
		Chuck for end milling cutter see MAPAL catalogue "CLAMPING"	

Spare parts*

	SD__0602	Clamping screw for indexable insert M2.2X5.2-TX7-IP	Order no. 31161853
-------------------------------------------------------------------------------------	----------	-----------------------------------------------------	-----------------------

CAM programming note

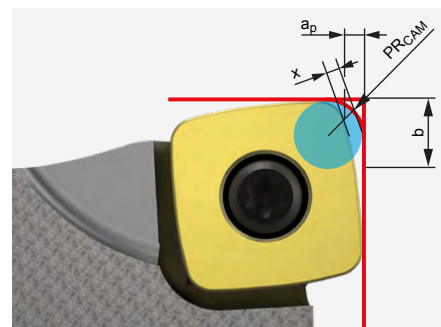

When using an HFC indexable insert, the programme radius PR_{CAM} must be observed.

SD__06

Dimensions			
PR_{CAM}	a_p	x	b
1,77	1,0	0,45	5,12

Dimensions in mm.

* Included in scope of delivery.

NeoMill®-4-HiFeed90

High-feed and 90° shoulder milling cutter
SD__10



End milling cutter



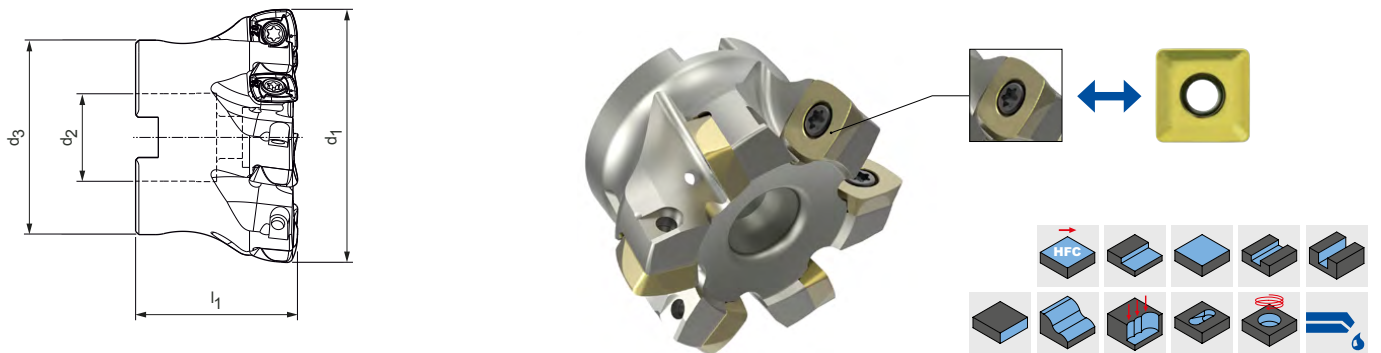

Dimensions				Z _{eff}	a _p max.		Weight [kg]	Internal cooling	Specification	Order no.
d ₁	d ₂	l ₁	l ₂		90°	HFC				
25	25	106	50	2	9	1,5	0,31	✓	IMH901-025-106-HB25-Z2R-SD__10	31144156
25	25	106	50	3	9	1,5	0,30	✓	IMH901-025-106-HB25-Z3R-SD__10	31144157
32	32	124	64	3	9	1,5	0,64	✓	IMH901-032-124-HB32-Z3R-SD__10	31144158



Milling cutter head

Dimensions				Z _{eff}	a _p max.		Weight [kg]	Internal cooling	Specification	Order no.
d ₁	d ₂	d ₃	l ₁		90°	HFC				
40	16	35	40	4	9	1,5	0,17	✓	IMH901-040-CA16-Z04R-SD__10	31144056
40	16	35	40	6	9	1,5	0,17	✓	IMH901-040-CA16-Z06R-SD__10	31144057
50	22	43	40	5	9	1,5	0,26	✓	IMH901-050-CA22-Z05R-SD__10	31144059
50	22	43	40	7	9	1,5	0,25	✓	IMH901-050-CA22-Z07R-SD__10	31144060
52	22	43	40	5	9	1,5	0,30	✓	IMH901-052-CA22-Z05R-SD__10	31144061
63	22	48	40	6	9	1,5	0,42	✓	IMH901-063-CA22-Z06R-SD__10	31144062
63	22	48	40	8	9	1,5	0,42	✓	IMH901-063-CA22-Z08R-SD__10	31144063
66	22	48	40	5	9	1,5	0,46	✓	IMH901-066-CA22-Z05R-SD__10	31144085
80	27	60	50	8	9	1,5	0,91	✓	IMH901-080-CA27-Z08R-SD__10	31144064

Accessories

	SD__1004	Indexable insert 90°	Page 328
	SD__1004	Indexable insert HFC	Page 326
		Milling cutter arbor for milling cutter head see MAPAL catalogue "CLAMPING"	
		Milling cutter clamping screw for milling cutter head	Page 386
		Chuck for end milling cutter see MAPAL catalogue "CLAMPING"	

Spare parts*

	SD__1004	Clamping screw for indexable insert M3X8.3-TX9-IP	Order no.
			31161852

CAM programming note

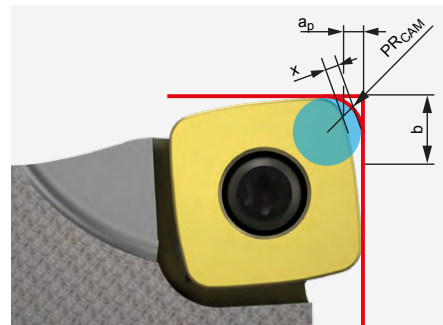

When using an HFC indexable insert, the programme radius PR_{CAM} must be observed.

SD__10

Dimensions [mm]			
PR_{CAM}	a_p	x	b
2,25	1,5	0,62	8,033

* Included in scope of delivery.

NeoMill®-4-HiFeed90

High-feed and 90° shoulder milling cutter
SD__14

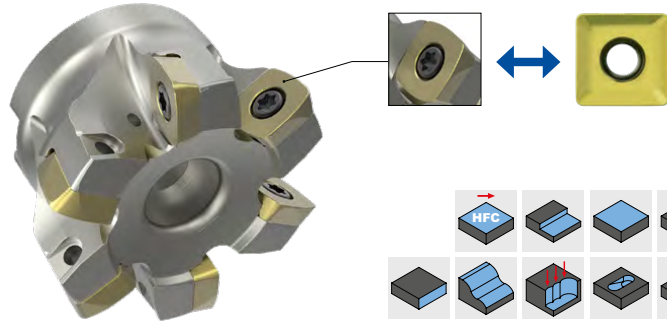
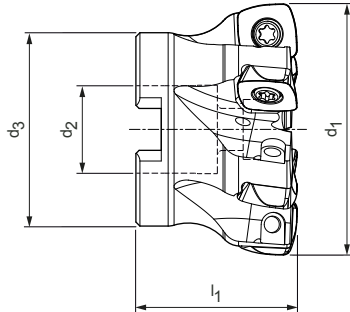

Milling cutter head

Dimensions				Z _{eff}	a _p max.		Weight [kg]	Internal cooling	Specification	Order no.
d ₁	d ₂	d ₃	l ₁		90°	HFC				
50	22	43	40	5	12,5	2,4	0,22	✓	IMH901-050-CA22-Z05R-SD__14	31144065
52	22	43	40	5	12,5	2,4	0,28	✓	IMH901-052-CA22-Z05R-SD__14	31144067
63	22	48	40	6	12,5	2,4	0,38	✓	IMH901-063-CA22-Z06R-SD__14	31144068
66	22	48	40	6	12,5	2,4	0,43	✓	IMH901-066-CA22-Z06R-SD__14	31144069
80	27	60	50	7	12,5	2,4	0,85	✓	IMH901-080-CA27-Z07R-SD__14	31144070
100	32	78	50	7	12,5	2,4	1,49	✓	IMH901-100-CA32-Z07R-SD__14	31144071
100	32	78	50	9	12,5	2,4	1,49	✓	IMH901-100-CA32-Z09R-SD__14	31144072
125	40	90	60	11	12,5	2,4	2,79	✓	IMH901-125-CA40-Z11R-SD__14	31144073

Accessories

	SD__1405	Indexable insert 90°	Page 328
	SD__1405	Indexable insert HFC	Page 326
		Milling cutter arbor for milling cutter head see MAPAL catalogue "CLAMPING"	
		Milling cutter clamping screw for milling cutter head	Page 386

Spare parts*

	SD__1405	Clamping screw for indexable insert M5X10.8-TX20-IP	Order no. 31161851
--	----------	-----------------------------------------------------	-----------------------

CAM programming note

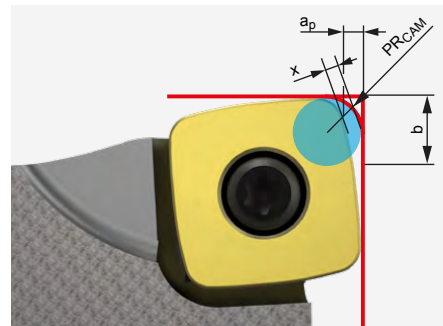

When using an HFC indexable insert, the programme radius P_{RCAM} must be observed.

SD__14

Dimensions [mm]			
P _{RCAM}	a _p	x	b
3,45	2,4	0,93	10,868

Dimensions in mm.

* Included in scope of delivery.

NeoMill®-4-HiFeed90

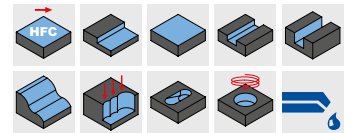
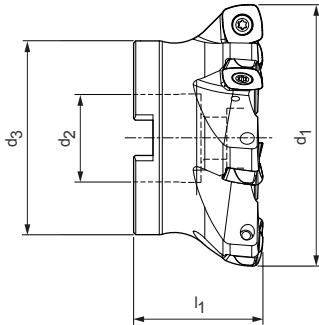

High-feed milling cutter
SD__18



Milling cutter head

Dimensions				Z_{eff}	a_p max.	Weight [kg]	Internal cooling	Specification	Order no.
d_1	d_2	d_3	l_1						
80	27	60	50	5	3,5	0,79	✓	IMH901-080-CA27-Z05R-SD__18	31144075
100	32	78	50	6	3,5	1,49	✓	IMH901-100-CA32-Z06R-SD__18	31144087
125	40	90	60	7	3,5	2,43	✓	IMH901-125-CA40-Z07R-SD__18	31144088
160	40	115	60	9	3,5	4,09	–	IMH900-160-CA40-Z09R-SD__18	31144089
200	60	140	65	11	3,5	5,83	–	IMH900-200-CA60-Z11R-SD__18	31144090

Accessories

	SD__1806	Indexable insert HFC	Page 326
		Milling cutter arbor for milling cutter head see MAPAL catalogue "CLAMPING"	
		Milling cutter clamping screw for milling cutter head	Page 386

Spare parts*

	SD__1806	Clamping screw for indexable insert M6X15-T25	Order no. 31161862
-------------------------------------------------------------------------------------	----------	-----------------------------------------------	-----------------------

CAM programming note

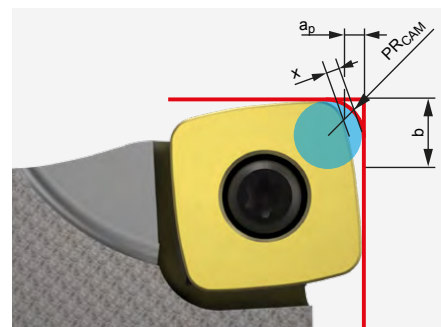

When using an HFC indexable insert, the programme radius PR_{CAM} must be observed.

SD__18

Dimensions [mm]			
PR_{CAM}	a_p	x	b
4,82	3,5	1,24	13,77

Dimensions in mm.

* Included in scope of delivery.

SDMT – SDMW

Radial indexable insert, four cutting edges

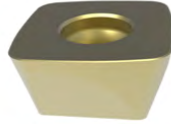

For high-feed machining

	Carbide				
Workpiece material	P				
	Unalloyed ← Wear-resistant	Alloyed → Tough/Ductile		Unalloyed ← Wear-resistant	Alloyed → Tough/Ductile
Coating	PVD			CVD	
Cutting material type	HP635	HP640	HP645	HC530	HC535
Cutting edge design	PMS	PMS		PMS	PMS

SDMT	a _p max. [mm]				
SDMT060212R-	1 *	31144355			
SDMT100415R-	1.5 *	31144367	31144368	31144365	31144366
SDMT140520R-	2.4 *	31144380	31144381	31144378	31144379
SDMT180630R-	3.5 *	31144384	31144385		

Cutting edge design		PRS	PRS	PRS	PRS	PRS
SDMW	a _p max. [mm]					
SDMW100415R-	1.5 *	31144393	31144394		31144391	31144392
SDMW140520R-	2.4 *	31144402	31144403		31144400	31144401
SDMW180630R-	3.5 *		31144407	31144408		

Feed per tooth (selection according to cutting edge design) and plunge angle

* MMG	Cutting edge design	SD_06			SD_10			SD_14			SD_18		
		KV	a _p max. [mm]	f _z [mm]	KV	a _p max. [mm]	f _z [mm]	KV	a _p max. [mm]	f _z [mm]	KV	a _p max. [mm]	f _z [mm]
P	PMS	-	0.3 0.5 1	0.4 0.6 1.1	Δ+	0.5 0.8 1.3	0.6 1 1.4	Δ+	0.6 1.2 2.2	0.7 1.4 2.2	Δ+	1 2.2 3.2	1.2 1.8 2.8
	PRS				Δ+	0.5 1 1.5	0.7 1.1 1.6	Δ+	0.7 1.5 2.4	0.8 1.6 2.4	Δ+	1 2.5 3.5	1.4 2.2 3
M	MQL	-	0.3 0.5 1	0.3 0.5 1	+	0.5 0.8 1.3	0.5 0.9 1.4	+	0.6 1.2 2.2	0.8 1.2 2.2	Δ+	1 2 3	1 1.6 2.5
K	KRS				Δ+	0.5 1 1.5	0.7 1.2 1.6	Δ+	0.7 1.6 2.4	0.8 1.7 2.4	Δ+	1 2.8 3.5	1.4 2.5 3
H	HMS	-	0.3 0.5 1	0.4 0.6 1.1					0.4 1.2 2.2	0.4 1.2 2.2			
	HRS				Δ+	0.4 0.8 1.2	0.4 1.1 1.6	Δ+	0.5 1.5 2.4	0.5 1.6 2.4	Δ+	1 2.2 3.5	0.8 1.8 2.8

Legend: KV = edge rounding | - = not specified | + = slightly rounded | Δ+ = bevelled and slightly rounded

* a_p max. depends on the type of milling cutter and application.

** MAPAL machining groups

Carbide						
M		K		H		
Austenitic		Ferritic		≥ 65 HRC		
Wear-resistant		Tough/Ductile		Wear-resistant		
PVD		PVD	CVD	PVD		CVD
HP650	HP655	HP630	HC525	HP320	HP325	HC220
MQL	MQL			HMS	HMS	

Dimensions [mm]				
l	d	s	d ₁	R

31144354				31144353	
31144363	31144364			31144362	31146714
31144376	31144377			31144375	
31144382	31144383				

1	6,75	2,5	2,5	1,2
1,1	10,2	4,86	3,5	1,5
2,2	14,7	5	5,5	2
3	18,7	6	6,5	3

		KRS	KRS	HRS	HRS	HRS
		31144390	31144389	31144387	31144388	31144386
		31144399	31144398	31144396	31144397	31144395
		31144406	31144405		31144404	

1,1	10,2	4,86	3,5	1,5
2,2	14,7	5	5,5	2
3	18,7	6	6,5	3

CAM programming note

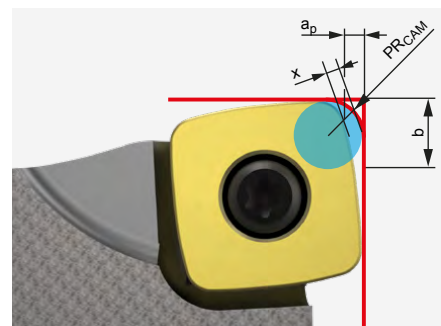

When using an HFC indexable insert, the programme radius PR_{CAM} must be observed.

Plunge angle | High-feed machining

Diameter [mm]	Plunge angle [°]			
	SDM_06	SDM_10	SDM_14	SDM_18
16	9	-	-	-
20	4.8	-	-	-
25	3	4.4	-	-
32	2	2.9	-	-
35	1.7	-	-	-
40	-	2	-	-
50	-	1.5	2.4	-
52	-	1.3	2.2	-
63	-	1.1	1.7	-
66	-	1	1.5	-
80	-	0.8	1.3	2.5
100	-	0.7	1	2
125	-	0.5	0.7	1.6
160	-	-	-	1.3
200	-	-	-	1

Dimensions [mm]				
	PR_{CAM}	a_p	x	b
SD_06	1,77	1,0	0,45	5,12
SD_10	2,25	1,5	0,62	8,033
SD_14	3,45	2,4	0,93	10,868
SD_18	4,82	3,5	1,24	13,77

SDHT – SDMT

Radial indexable insert, four cutting edges

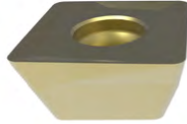

For 90° machining

		Carbide		
Workpiece material	P			
	Unalloyed	Alloyed		
	← Wear-resistant	Tough/Ductile →		
Coating	PVD			
Cutting material type		HP635	HP640	HP645
Cutting edge design				
SDHT		a_p max. [mm]		
SDHT100404R-		9 *		
SDHT100408R-		9 *		
SDHT140508R-		12.5 *		
SDHT140512R-		12.5 *		
Cutting edge design		PMU	PMU	PMU
SDMT		a_p max. [mm]		
SDMT100408R-		9 *	31144359	31144360
SDMT140512R-		12.5 *	31144372	31144373
				31144361
				31144374

Feed per tooth (selection according to cutting edge design)

* MMG	Cutting edge design	SD_10						SD_14							
		KV	a _p max. [mm]			f _z [mm]		KV	a _p max. [mm]			f _z [mm]			
P	PMU	Δ+	0.8	3	9	0.1	0.18	0.23	Δ+	1.2	6	12.5	0.1	0.2	0.25
M	MMU	+	0.8	3	9	0.08	0.14	0.2	+	1.2	6	12.5	0.1	0.15	0.22
K	KMU	Δ+	0.8	3	9	0.1	0.2	0.26	Δ+	1.2	6	12.5	0.1	0.22	0.28
N	NMU	0	0.8	5	9	0.05	0.12	0.2	0	1.2	8	12.5	0.06	0.14	0.22

Legend: KV = edge rounding | 0 = sharp edged | + = slightly rounded | Δ+ = bevelled and slightly rounded

* a_p max. depends on the type of milling cutter and application.

** MAPAL machining groups

Carbide				
M		K		N
Austenitic ← Wear-resistant		Ferritic → Tough/Ductile		
PVD		PVD	Uncoated	PVD
HP650	HP655	HP630	HU110	HP110
			NMU	NMU

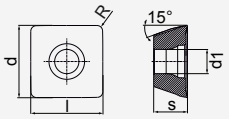
Dimensions [mm]				
				
l	d	s	d ₁	R

			31144412	31144349
			31144413	31144350
			31144414	31144351
			31144415	31144352

10,4	10,4	4,86	3,5	0,4
10,4	10,4	4,86	3,5	0,8
14,8	14,8	5,2	5,5	0,8
14,8	14,8	5,2	5,5	1,2

MMU	MMU	KMU		
31144357	31144358	31144356		
31144370	31144371	31144369		

10,4	10,4	4,86	3,5	0,8
14,8	14,8	5,2	5,5	1,2

Plunge angle | 90° machining

Diameter [mm]	Plunge angle [°]	
	SD__10	SD__14
25	7	-
32	4.6	-
40	3.3	-
50	2.4	5.5
52	2.2	5.3
63	1.8	3.7
66	1.6	3.4
80	1.3	2.6
100	1	1.9
125	0.8	1.5
160	0.5	-

Cutting data recommendations for high-feed milling cutters

Feed and cutting speed

High-feed milling cutter

MMG*	Workpiece material	Strength/hardness [N/mm ²] [HRC]	Cooling			
			MQL/Air	Dry	Coolant	
P	P1.1	Structural, free-cutting, case hardened and heat-treated steels, non-alloy	< 700		✓	
	P1.2	Structural, free-cutting, case hardened and heat-treated steels, non-alloy	< 1200		✓	
	P2.1	Nitrided, case hardened and heat-treated steels, alloy	< 900		✓	
	P2.2	Nitrided, case hardened and heat-treated steels, alloy	< 1400		✓	
	P3.1	Tool, bearing, spring and high-speed steels**	< 800		✓	
	P3.2	Tool, bearing, spring and high-speed steels**	< 1000		✓	
	P3.3	Tool, bearing, spring and high-speed steels**	< 1500		✓	
	P4.1	Stainless steels, ferritic and martensitic				
	P5.1	Cast steel				
	P6.1	Stainless cast steel, ferritic and martensitic				
M	M1.1	Stainless steels, austenitic	< 700		✓	
	M1.2	Stainless steels, ferritic/austenitic (duplex)	< 1000			
	M2.1	Stainless/heat-resistant cast steel, austenitic	< 700			
	M3.1	Stainless cast steel, ferritic/austenitic (duplex)	< 1000			
K	K1.1	Cast iron with lamellar graphite (grey cast iron), GJL	< 300		✓	
	K2.1	Cast iron with spheroidal graphite, GJS	< 500		✓	
	K2.2	Cast iron with spheroidal graphite, GJS	500-800			
	K2.3	Cast iron with spheroidal graphite, GJS	> 800			
	K3.1	Cast iron with spheroidal graphite, GJV; malleable cast iron, GJM	< 500			
	K3.2	Cast iron with spheroidal graphite, GJV; malleable cast iron, GJM	> 500			
N	N1.1	Aluminium, non-alloy and alloy < 3 % Si				✓
	N1.2	Aluminium, alloy ≤ 7 % Si				✓
	N1.3	Aluminium, alloy > 7-12 % Si				✓
	N1.4	Aluminium, alloy > 12 % Si				✓
	N2.1	Copper, non-alloy and low-alloy	< 300			✓
	N2.2	Copper, alloy	> 300			✓
	N2.3	Brass, bronze, gunmetal	< 1200			✓
H	H1.1	Hardened steel / cast steel	< 44		✓	
	H1.2	Hardened steel / cast steel	< 55		✓	
	H2.1	Hardened steel / cast steel	< 60		✓	
	H2.2	Hardened steel / cast steel	< 65		✓	
	H2.3	Hardened steel / cast steel	< 68		✓	
	H3.1	Wear-resistant cast/chill casting, GJN			✓	

* MAPAL machining groups

** If the alloy parts Cr, Mo, Ni, V, W in total > 8%, then select the next highest MAPAL machining group.

v _c [m/min] according to cutting material type and contact ratio a _e /D																											
Carbide PVD-coated																Carbide CVD-coated						Carbide uncoated					
HP110		HP320		HP325		HP630		HP635		HP640		HP645		HP650		HP655		HC220		HC525		HC530		HC535		HU110	
> 0.6	< 0.6	> 0.6	< 0.6	> 0.6	< 0.6	> 0.6	< 0.6	> 0.6	< 0.6	> 0.6	< 0.6	> 0.6	< 0.6	> 0.6	< 0.6	> 0.6	< 0.6	> 0.6	< 0.6	> 0.6	< 0.6	> 0.6	< 0.6	> 0.6	< 0.6	> 0.6	< 0.6
								220	290	180	230	130	220									220	310	180	250		
								190	260	150	200	100	190									190	280	150	220		
								190	230	160	180	180	220									190	250	160	200		
								160	200	130	150	150	190									160	220	130	170		
								170	210	130	160	160	190									170	230	130	180		
								150	190	120	150	150	180									150	210	120	180		
								130	170	100	130	130	160									130	190	100	160		
								130	170													130	190	120	180		
								140	180													140	200	130	190		
								120	160													120	180	110	170		
														140	180	130	160										
														110	150	100	130										
														110	130	100	120										
														80	100	70	90										
							180	320													210	360					
							150	200													180	250					
							140	180													170	230					
							130	160													160	210					
							140	180													170	230					
							130	160													160	210					
500	3000																									400	2500
400	500																									300	400
400	500																									300	400
400	500																									300	400
160	500																									120	400
200	300																									160	250
200	300																									160	250
		100	180	90	140															110	190						
		90	150	70	130															100	160						
		60	80																	60	90						
		65	95	60	90															70	100						

The specified machining values are guide values.
 The optimum data for the respective machining task should be determined during the test or machining.

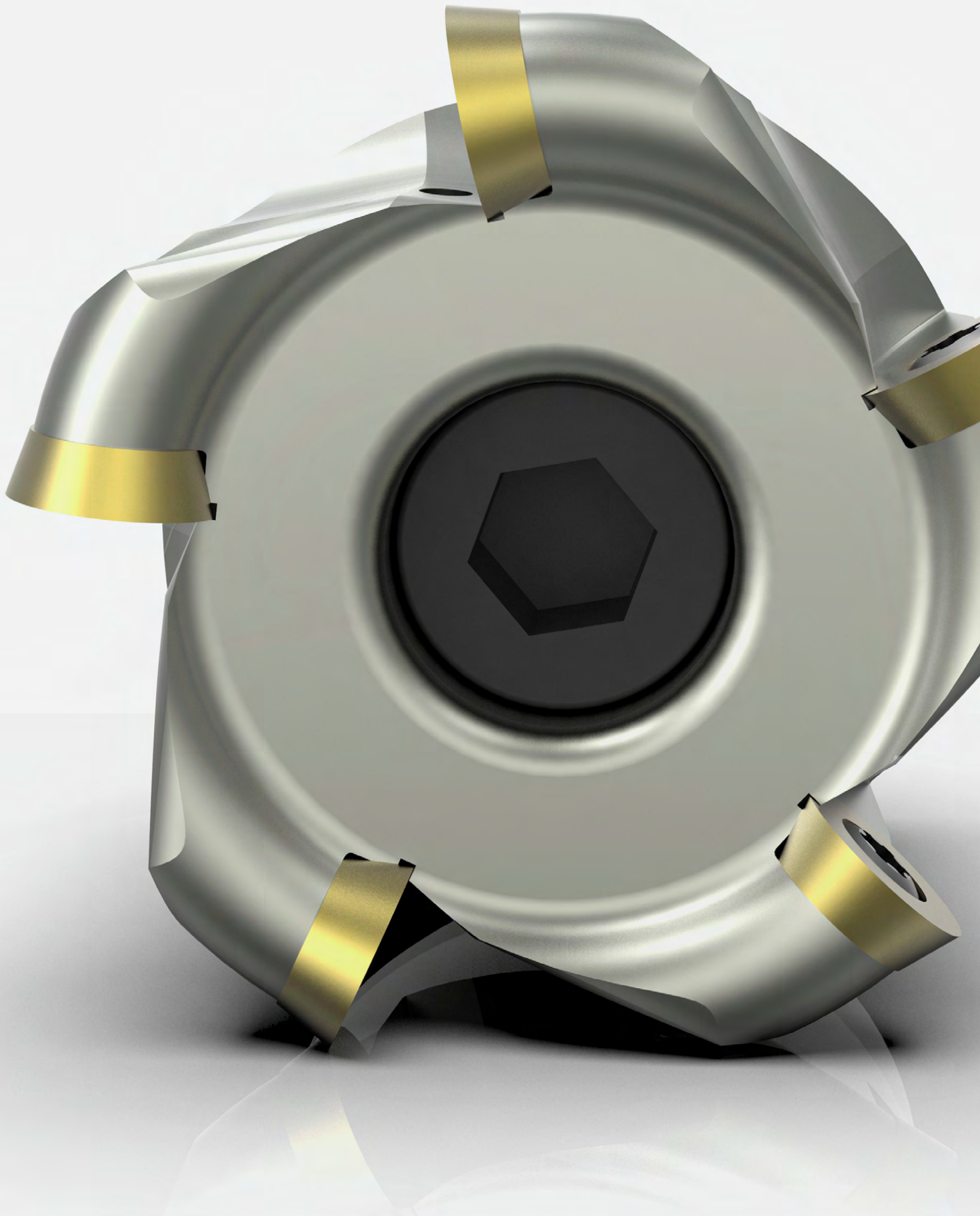



COPY MILLING CUTTER

NeoMill – radial technology

NeoMill-ISO-360, RD__07	_____	334
NeoMill-ISO-360, RD__10	_____	335
NeoMill-ISO-360, RD__12	_____	336
NeoMill-ISO-360, RD__16	_____	337

Accessories and spare parts

Accessories for indexable inserts	_____	384
Allocating milling cutter clamping screws	_____	386

Technical appendix

Cutting data recommendations	_____	340
Handling notes Milling cutter clamping screw	_____	412

NeoMill-ISO-360

Round-insert milling cutter, radius 3.5 mm
RD__07

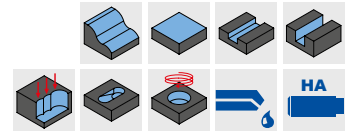
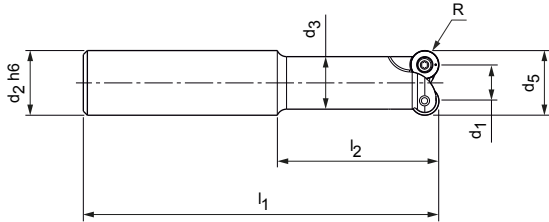

End milling cutter, cylindrical design

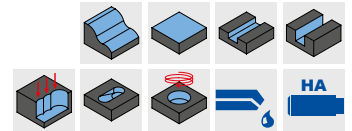
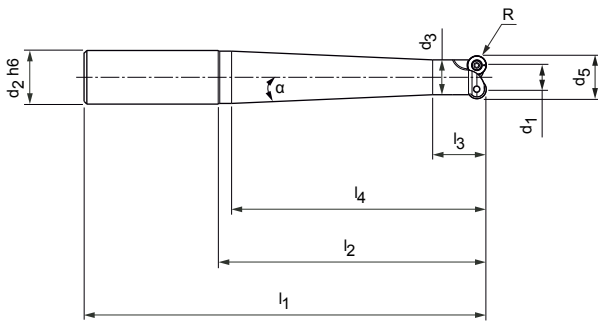

Dimensions						Z _{eff}	R	Weight [kg]	Internal cooling	Specification	Order no.
d ₁	d ₂ h6	d ₃	d ₅	l ₁	l ₂						
8	16	13	15	88	40	2	3,5	0,11	✓	IMR001-015-088-HA16-Z2R-RD__07	31144105
9	16	13	16	88	40	2	3,5	0,11	✓	IMR001-016-088-HA16-Z2R-RD__07	31144106



End milling cutter, conical design

Dimensions								Z _{eff}	R	Weight [kg]	Internal cooling	Specification	Order no.
d ₁	d ₂ h6	d ₃	l ₁	l ₂	l ₃	l ₄	α						
15	16	13	108	60	20	55	2,0°	2	3,5	0,14	✓	IMR101-015-108-HA16-Z2R-RD__07	31144092
15	20	13	130	80	20	75	3,4°	2	3,5	0,23	✓	IMR101-015-130-HA20-Z2R-RD__07	31144093
15	20	13	150	100	20	95	2,5°	2	3,5	0,26	✓	IMR101-015-150-HA20-Z2R-RD__07	31144094
15	25	13	176	120	20	115	3,5°	2	3,5	0,45	✓	IMR101-015-176-HA25-Z2R-RD__07	31144095
16	16	13	108	60	20	55	2,0°	2	3,5	0,14	✓	IMR101-016-108-HA16-Z2R-RD__07	31144096
16	20	13	130	80	20	75	3,4°	2	3,5	0,24	✓	IMR101-016-130-HA20-Z2R-RD__07	31144097
16	20	13	150	100	20	95	2,5°	2	3,5	0,27	✓	IMR101-016-150-HA20-Z2R-RD__07	31144098
16	25	13	176	120	20	115	3,5°	2	3,5	0,45	✓	IMR101-016-176-HA25-Z2R-RD__07	31144099

Accessories

	RD__0702	Indexable insert	Page 338
		Chuck for end milling cutter see MAPAL catalogue "CLAMPING"	

Spare parts*

	RD__0702	Clamping screw for indexable insert M2.5X5.5-TX7-IP	Order no. 31161854
-------------------------------------------------------------------------------------	----------	-----------------------------------------------------	-----------------------

Dimensions in mm.

* Included in scope of delivery.

NeoMill-ISO-360

Round-insert milling cutter, radius 5 mm

RD__10

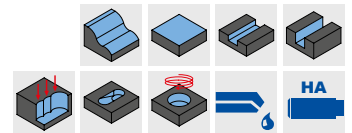
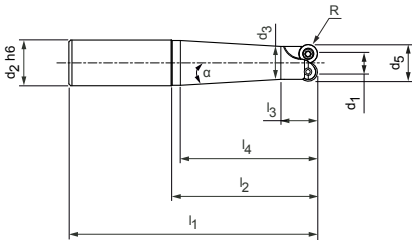

End milling cutter, conical design



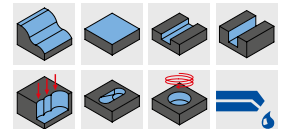
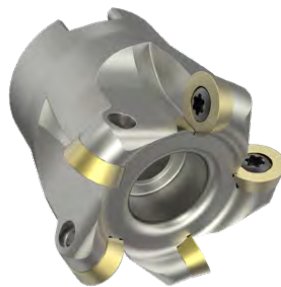
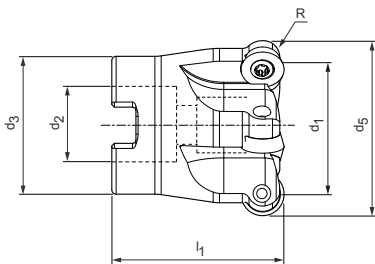

Dimensions								Z_{eff}	R	Weight [kg]	Internal cooling	Specification	Order no.
d_1	d_2 h6	d_3	l_1	l_2	l_3	l_4	α						
20	20	18	90	40	20	35	2,9°	2	5	0,18	✓	IMR101-020-090-HA20-Z2R-RD__10	31144100
20	20	18	110	60	20	55	1,3°	2	5	0,22	✓	IMR101-020-110-HA20-Z2R-RD__10	31144101
20	25	18	136	80	20	75	3,4°	2	5	0,40	✓	IMR101-020-136-HA25-Z2R-RD__10	31144102
20	25	18	156	100	20	95	2,5°	2	5	0,45	✓	IMR101-020-156-HA25-Z2R-RD__10	31144103
20	25	18	176	120	20	115	2,0°	2	5	0,50	✓	IMR101-020-176-HA25-Z2R-RD__10	31144104



Milling cutter head

Dimensions					Z_{eff}	R	Weight [kg]	Internal cooling	Specification	Order no.
d_1	d_2	d_3	d_5	l_1						
30	16	32	40	40	5	5	0,18	✓	IMR001-040-CA16-Z05R-RD__10	31143968
32	16	32	42	40	5	5	0,20	✓	IMR001-042-CA16-Z05R-RD__10	31143969
42	22	40	52	50	5	5	0,40	✓	IMR001-052-CA22-Z05R-RD__10	31144030
42	22	40	52	50	7	5	0,30	✓	IMR001-052-CA22-Z07R-RD__10	31144031

Accessories

	RD__1003	Indexable insert	Page 338
		Milling cutter arbor for milling cutter head see MAPAL catalogue "CLAMPING"	
		Milling cutter clamping screw for milling cutter head	Page 386
		Chuck for end milling cutter see MAPAL catalogue "CLAMPING"	

Spare parts*

	RD__1003	Clamping screw for indexable insert M3.5X7.2-TX15-IP	Order no. 31161859
-------------------------------------------------------------------------------------	----------	------------------------------------------------------	-----------------------

Dimensions in mm.
* Included in scope of delivery.

NeoMill-ISO-360

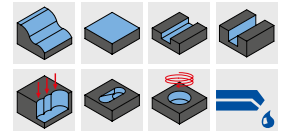
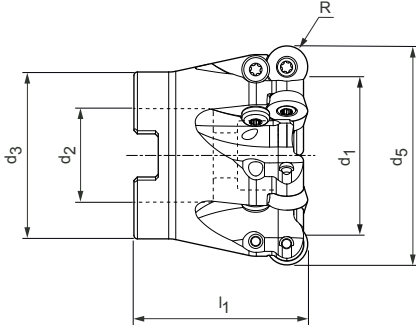

Round-insert milling cutter, radius 6 mm
RD__12





Milling cutter head

Dimensions					Z _{eff}	R	Weight [kg]	Internal cooling	Specification	Order no.
d ₁	d ₂	d ₃	d ₅	l ₁						
30	16	32	42	40	4	6	0,14	✓	IMR001-042-CA16-Z04R-RD__12	31144032
36	22	40	48	50	4	6	0,32	✓	IMR001-048-CA22-Z04R-RD__12	31144033
38	22	40	50	50	5	6	0,36	✓	IMR001-050-CA22-Z05R-RD__12	31144034
40	22	40	52	50	5	6	0,34	✓	IMR001-052-CA22-Z05R-RD__12	31144035
51	27	48	63	50	6	6	0,52	✓	IMR001-063-CA27-Z06R-RD__12	31144036
54	27	48	66	50	6	6	0,58	✓	IMR001-066-CA27-Z06R-RD__12	31144037
68	27	60	80	52	7	6	0,99	✓	IMR001-080-CA27-Z07R-RD__12	31144038

Accessories

	RD__12T3	Indexable insert	Page 338
		Milling cutter arbor for milling cutter head see MAPAL catalogue "CLAMPING"	
		Milling cutter clamping screw for milling cutter head	Page 386

Spare parts*

	RD__12T3	Clamping screw for indexable insert M3.5X8.6-TX15-IP	Order no. 31161860
	RD__12T3	Rotation lock M3.5X7.2-TX15-IP	Order no. 31161928

Dimensions in mm.

The maximum operating speeds refer only to the cutting edge system.

* Included in scope of delivery.

Depending on the clamping device used, different maximum operating speeds must be observed.

NeoMill-ISO-360

Round-insert milling cutter, radius 8 mm

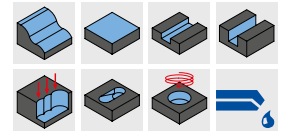
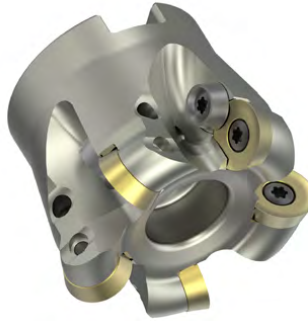
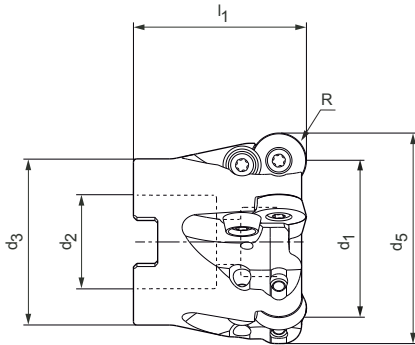

RD__16





Milling cutter head

Dimensions					Z _{eff}	R	Weight [kg]	Internal cooling	Specification	Order no.
d ₁	d ₂	d ₃	d ₅	l ₁						
34	22	40	50	50	4	8	0,27	✓	IMR001-050-CA22-Z04R-RD__16	31144039
36	22	40	52	50	4	8	0,30	✓	IMR001-052-CA22-Z04R-RD__16	31144040
47	27	48	63	50	5	8	0,44	✓	IMR001-063-CA27-Z05R-RD__16	31144041
50	27	48	66	50	5	8	0,67	✓	IMR001-066-CA27-Z05R-RD__16	31144042
64	27	60	80	52	6	8	0,99	✓	IMR001-080-CA27-Z06R-RD__16	31144044
64	27	60	80	52	7	8	0,97	✓	IMR001-080-CA27-Z07R-RD__16	31144045
84	32	70	100	52	7	8	1,28	✓	IMR001-100-CA32-Z07R-RD__16	31144046
109	40	90	125	63	8	8	2,66	✓	IMR001-125-CA40-Z08R-RD__16	31144047
144	40	128	160	63	9	8	4,18	✓	IMR001-160-CA40-Z09R-RD__16	31144048

Accessories

	RD__1604	Indexable insert	Page 338
		Milling cutter arbor for milling cutter head see MAPAL catalogue "CLAMPING"	
		Milling cutter clamping screw for milling cutter head	Page 386

Spare parts*

	RD__1604	Clamping screw for indexable insert M4.5X10.5-TX20-IP	Order no. 31161861
	RD__1604	Clamping screw for clamping plate M4.5X10.5-TX20-IP	Order no. 31161861
	RD__1604	Clamping plate	Order no. 31161929

Dimensions in mm.

The maximum operating speeds refer only to the cutting edge system.

* Included in scope of delivery.

Depending on the clamping device used, different maximum operating speeds must be observed.

RDKW – RDKT – RDHW – RDHT

Radial indexable insert, round insert

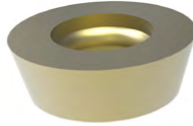

	Carbide				
Workpiece material	P		M		
	Unalloyed ← Wear-resistant	Alloyed → Tough/Ductile	Austenitic ← Wear-resistant	Ferritic → Tough/Ductile	
Coating	PVD		PVD		
Cutting material type	HP635	HP640	HP650	HP655	
Cutting edge design	PMU	PMU	MMU	MMU	
RDKW	<i>a_p max. [mm]</i>				
RDKW0501M0N-	1.2 *	31144308		31144305	31144306
RDKW0702M0N-	1.7 *	31144318	31144319	31144314	31144315
RDKW1003M0N-	2.5 *	31144329	31144330	31144325	31144326
RDKW12T3M0N-	3 *	31144338	31144339		
RDKW1604M0N-	4 *	31144347	31144348		
RDKT					
RDKT12T3M0N-	3 *	31144292	31144293	31144288	31144289
RDKT1604M0N-	4 *	31144298	31144299	31144294	31144295
RDHW					
RDHW0501M0N-	0.45 *				
RDHW0702M0N-	0.85 *				
RDHW1003M0N-	1.2 *				
RDHW12T3M0N-	1.5 *				
RDHW1604M0N-	2 *				
RDHT					
RDHT12T3M0N-	3 *			31144283	31144284

Feed per tooth (selection according to cutting edge design)

* MMG	Cutting edge design	RD_0501							RD_0702						
		KV	<i>a_p max. [mm]</i>			<i>f_z [mm]</i>			KV	<i>a_p max. [mm]</i>			<i>f_z [mm]</i>		
P	PMU	Δ+	0.25	0.7	1.2	0.14	0.26	0.5	Δ+	0.25	1	1.7	0.14	0.27	0.6
M	MMU	Δ+	0.25	0.7	1.2	0.13	0.23	0.45	Δ+	0.25	1	1.7	0.13	0.24	0.52
K	KMU	Δ+	0.25	0.7	1.2	0.15	0.27	0.53	Δ+	0.25	1	1.7	0.15	0.28	0.63
H	HFU	Δ+	0.1	0.18	0.45	0.1	0.2	0.36	Δ+	0.1	0.2	0.65	0.11	0.22	0.42
	HMU	Δ+	0.1	0.18	0.45	0.1	0.2	0.36	Δ+	0.1	0.2	0.65	0.11	0.22	0.42
	HRU	Δ+	0.12	0.24	0.6	0.1	0.22	0.4	Δ+	0.12	0.25	0.85	0.11	0.25	0.46

Legend: KV = edge rounding | Δ+ = bevelled and slightly rounded

* *a_p max.* depends on the type of milling cutter and application.

** MAPAL machining groups

Carbide					
K	H	≥ 65 HRC		60 HRC	58 HRC
		Wear-resistant		Tough/Ductile	
PVD	CVD	PVD			
HP630	HC220	HP310	HP320	HP325	
KMU	HMU	HFU	HMU	HRU	

Dimensions [mm]

d	s	d ₁
---	---	----------------

31144304			31144301	31144302
31144313			31144310	31144311
31144324			31144321	31144322
31144335			31144332	31144333
31144344			31144341	31144342

5	1,5	2,2
7	2,38	2,7
10	3,18	3,9
12	3,97	3,9
16	4,76	5,2

12	3,97	3,9
16	4,76	5,2

		31144285		
	31146700	31144286	31146701	31146702
	31146703	31144287	31146704	31146705
	31146707	31146706	31146708	31146709
	31146711	31146710	31146712	31146713

5	1,5	2,2
7	2,38	2,7
10	3,18	3,9
12	3,97	3,9
16	4,76	5,2

--	--	--	--	--

12	3,97	4,4
----	------	-----

	RD_1003					RD_12T3					RD_1604										
	KV	a _p max. [mm]		f _z [mm]		KV	a _p max. [mm]		f _z [mm]		KV	a _p max. [mm]		f _z [mm]							
	Δ+	0.28	1.5	2.5	0.15	0.28	0.64	Δ+	0.3	1.8	3	0.16	0.29	0.7	Δ+	0.3	2.4	4	0.18	0.3	0.75
	Δ+	0.26	1.5	2.5	0.14	0.25	0.55	Δ+*	0.27	1.8	3	0.15	0.25	0.6	Δ+	0.27	2.4	4	0.16	0.25	0.64
	Δ+	0.28	1.5	2.5	0.16	0.3	0.67	Δ+	0.3	1.8	3	0.18	0.32	0.75	Δ+	0.3	2.4	4	0.18	0.33	0.8
	Δ+	0.12	0.22	0.9	0.12	0.28	0.45	Δ+	0.12	0.25	1.1	0.13	0.28	0.5	Δ+	0.12	0.28	1.6	0.14	0.28	0.5
	Δ+	0.12	0.22	0.9	0.12	0.28	0.45	Δ+	0.12	0.25	1.1	0.13	0.28	0.5	Δ+	0.12	0.28	1.6	0.14	0.28	0.5
	Δ+	0.14	0.28	1.2	0.12	0.3	0.5	Δ+	0.14	0.3	1.5	0.13	0.3	0.56	Δ+	0.15	0.35	2	0.14	0.3	0.56

* no indication for RDHT

Cutting data recommendations for copy milling cutter

Feed and cutting speed

Copy milling cutter

MMG*		Workpiece material	Strength/hardness [N/mm ²] [HRC]	Cooling		
				MQL/Air	Dry	Coolant
P	P1	P1.1 Structural, free-cutting, case hardened and heat-treated steels, non-alloy	< 700		✓	
		P1.2 Structural, free-cutting, case hardened and heat-treated steels, non-alloy	< 1200		✓	
	P2	P2.1 Nitrided, case hardened and heat-treated steels, alloy	< 900		✓	
		P2.2 Nitrided, case hardened and heat-treated steels, alloy	< 1400		✓	
	P3	P3.1 Tool, bearing, spring and high-speed steels**	< 800		✓	
		P3.2 Tool, bearing, spring and high-speed steels**	< 1000		✓	
		P3.3 Tool, bearing, spring and high-speed steels**	< 1500		✓	
	P4	P4.1 Stainless steels, ferritic and martensitic				
	P5	P5.1 Cast steel				
	P6	P6.1 Stainless cast steel, ferritic and martensitic				
M	M1	M1.1 Stainless steels, austenitic	< 700		✓	
		M1.2 Stainless steels, ferritic/austenitic (duplex)	< 1000			
	M2	M2.1 Stainless/heat-resistant cast steel, austenitic	< 700			
	M3	M3.1 Stainless cast steel, ferritic/austenitic (duplex)	< 1000			
K	K1	K1.1 Cast iron with lamellar graphite (grey cast iron), GJL	< 300		✓	
		K2.1 Cast iron with spheroidal graphite, GJS	< 500		✓	
	K2	K2.2 Cast iron with spheroidal graphite, GJS	500-800			
		K2.3 Cast iron with spheroidal graphite, GJS	> 800			
	K3	K3.1 Cast iron with spheroidal graphite, GJV; malleable cast iron, GJM	< 500			
		K3.2 Cast iron with spheroidal graphite, GJV; malleable cast iron, GJM	> 500			
H	H1	H1.1 Hardened steel / cast steel	< 44		✓	
		H1.2 Hardened steel / cast steel	< 55		✓	
	H2	H2.1 Hardened steel / cast steel	< 60		✓	
		H2.2 Hardened steel / cast steel	< 65		✓	
	H3	H2.3 Hardened steel / cast steel	< 68		✓	
		H3.1 Wear-resistant cast/chill casting, GJN			✓	

* MAPAL machining groups

** If the alloy parts Cr, Mo, Ni, V, W in total > 8%, then select the next highest MAPAL machining group.

v _c [m/min] according to cutting material type and contact ratio a _e /D																		
Carbide PVD-coated																	CVD-coated	
HP310		HP320		HP325		HP630		HP635		HP640		HP650		HP655		HC220		
> 0.6	< 0.6	> 0.6	< 0.6	> 0.6	< 0.6	> 0.6	< 0.6	> 0.6	< 0.6	> 0.6	< 0.6	> 0.6	< 0.6	> 0.6	< 0.6	> 0.6	< 0.6	
								230	300	200	260							
								200	270	170	230							
								210	280	180	240							
								180	250	150	210							
								190	250	170	220							
								170	230	160	210							
								150	210	140	190							
								150	210									
								160	220									
								140	200									
												140	180	130	160			
												110	150	100	130			
												110	130	100	120			
												80	100	70	90			
							230	360										
							200	250										
							190	230										
							180	210										
							190	230										
							180	210										
90	290	80	270	90	180												80	270
70	230	60	210	60	170												60	190
60	190	50	170	50	130												50	150
50	140	40	120														40	120
60	140	50	120														50	120

The specified machining values are guide values.

The optimum data for the respective machining task should be determined during the test or machining.

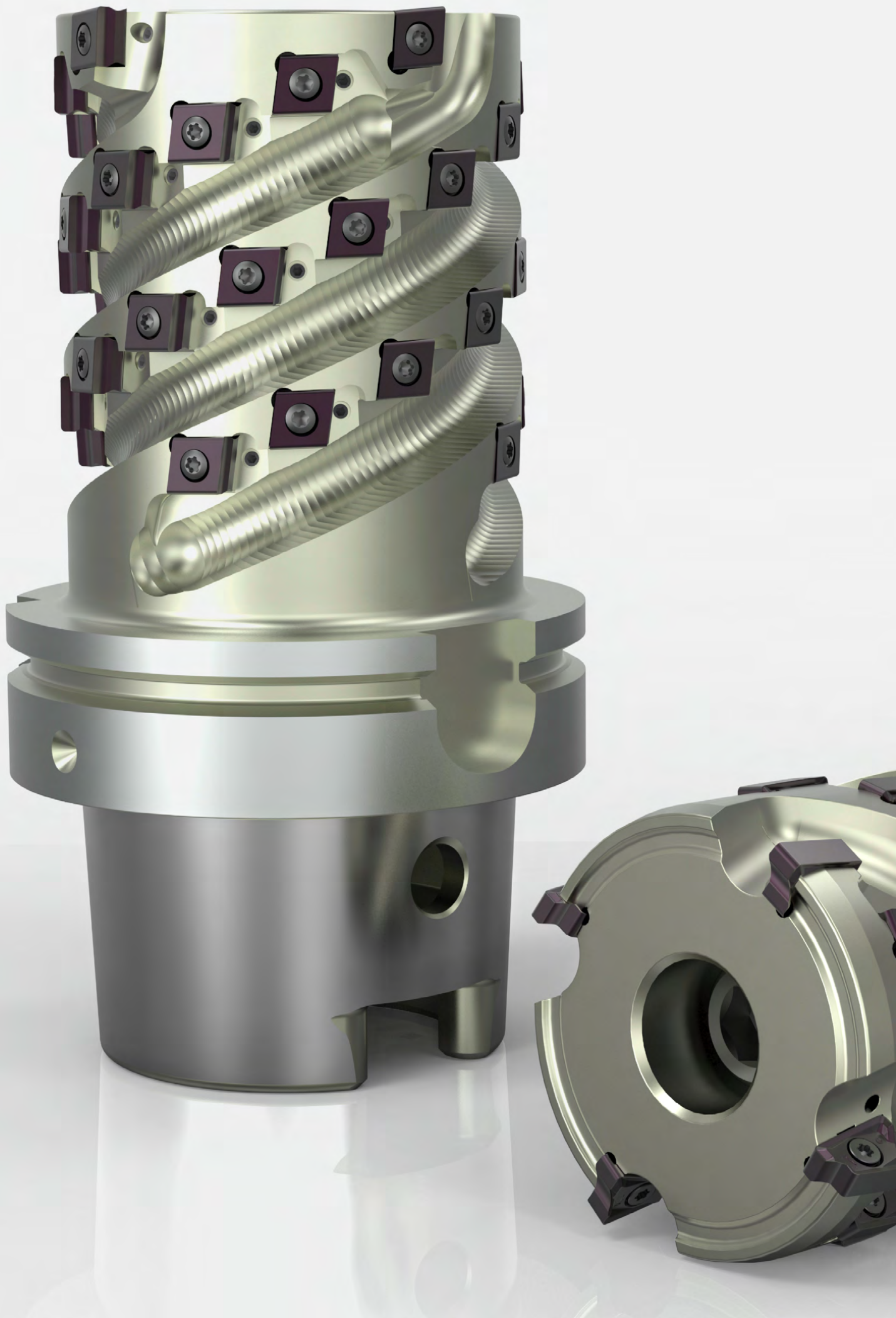

SHELL END FACE MILLING CUTTER

NeoMill – radial technology

NeoMill-2-Shell, AOKT	344
NeoMill-4-Shell, ANMU	346

TGMill – tangential technology

TGMill-2-Shell, CTHD	348
TGMill-4-Shell, CT_Q09	350

Accessories and spare parts

Accessories for indexable inserts	384
Allocating milling cutter clamping screws	386

Technical appendix

Cutting data recommendations	354
Handling notes Milling cutter clamping screw	412

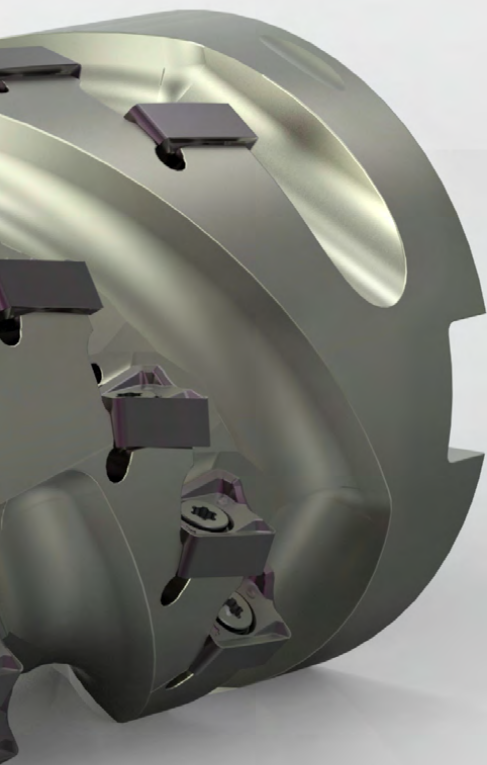

NeoMill®-2-Shell

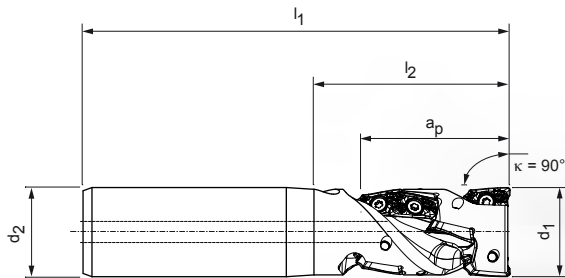

Shell end face milling cutter with radial technology
AOKT12



End milling cutter

Dimensions				Z_{eff}	Number of indexable inserts	a_p max.	Weight [kg]	Max. operating speed [min^{-1}]	Cylindrical shank form	Internal cooling	Specification	Order no.
d_1	d_2	l_1	l_2									
25	25	120	55	2	8	41	0,4	49.000	HA	✓	ISM901-025-HA25-Z02R-AO_T12	31002194
25	25	104	46	2	8	41	0,3	49.000	HB	✓	ISM901-025-HB25-Z02R-AO_T12	31002195
32	32	140	75	3	15	51	0,7	43.000	HA	✓	ISM901-032-HA32-Z03R-AO_T12	31002196
32	32	120	57	3	15	51	0,6	43.000	HB	✓	ISM901-032-HB32-Z03R-AO_T12	31002197
40	32	150	80	4	20	51	1,0	39.000	HA	✓	ISM901-040-HA32-Z04R-AO_T12	31002198
40	32	126	64	4	20	51	0,8	39.000	HB	✓	ISM901-040-HB32-Z04R-AO_T12	31002199

Accessories

	AOKT12T3	Indexable inserts	Page 345
		Chuck for end milling cutter see MAPAL catalogue "CLAMPING"	

Spare parts*

	AOKT12T3	Clamping screw for indexable insert TORX® M3x7.5-TX8-IP	Order no. 10105075
-------------------------------------------------------------------------------------	----------	---------------------------------------------------------	-----------------------

Dimensions in mm.

The maximum operating speeds refer only to the cutting edge system.

* Included in scope of delivery.

AOKT

Radial indexable insert, double edge

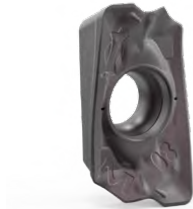

Workpiece material	P			M		K	
	Unalloyed Wear-resistant	Alloyed Tough/Ductile		Austenitic Wear-resistant	Ferritic Tough/Ductile		
Substrate	Carbide			Carbide		Carbide	
Coating	PVD		CVD	PVD		PVD	CVD
Cutting material type	HP975	HP980	HC775	HP980	HP985	HP975	HC770
Cutting edge design	M05	M03	M03	M03	M03	M05	M05
AOKT12	a_p max. [mm]						
AOKT12T304R-	*	31029366			31029367	31029366	31029368
AOKT12T308R-	*	31029368	31200903	31124557	31200903	31029369	31029368 31124556

Feed per tooth

Application		Medium machining			
		M03		M05	
Cutting edge design		PVD	CVD	PVD	CVD
Coating					
Edge rounding		++	++	+++	+++
Feed/tooth [mm]	P	0.08 - 0.25	0.08 - 0.19	0.1 - 0.25	0.1 - 0.19
	M	0.08 - 0.2	0.08 - 0.15		
	K			0.1 - 0.3	0.1 - 0.23
	N				

Legend: ++ = medium rounded | +++ = heavily rounded

* a_p max. depends on the type of milling cutter and application.
For related clamping screw and screwdriver see page 384.
For cutting data recommendations, see end of chapter.

NeoMill®-4-Shell

Shell end face milling cutter with radial technology
ANMU12

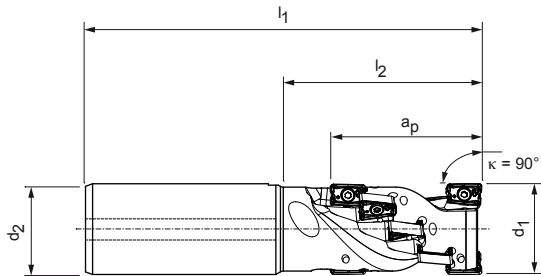

End milling cutter

Dimensions				Z _{eff}	Number of indexable inserts	a _p max.	Weight [kg]	Max. operating speed [min ⁻¹]	Cylindrical shank form	Internal cooling	Specification	Order no.
d ₁	d ₂	l ₁	l ₂									
32	32	140	70	2	10	52	0,7	29.000	HA	✓	ISM901-032-HA32-Z02R-AN_U12	31002236
32	32	125	61	2	10	52	0,6	29.000	HB	✓	ISM901-032-HB32-Z02R-AN_U12	31002237
40	32	150	80	3	18	62	0,9	26.000	HA	✓	ISM901-040-HA32-Z03R-AN_U12	31002238
40	32	135	73	3	18	62	0,8	26.000	HB	✓	ISM901-040-HB32-Z03R-AN_U12	31002239

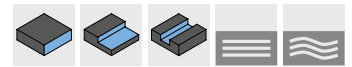
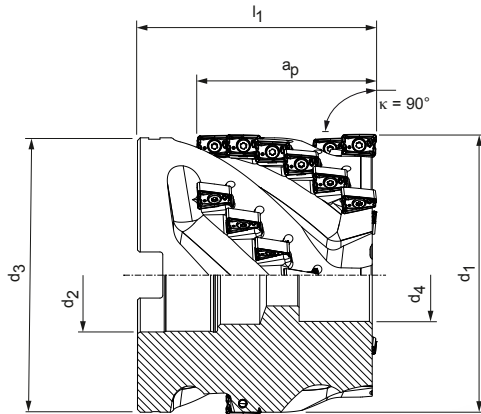

Milling cutter head

Dimensions					Z _{eff}	Number of indexable inserts	a _p max.	Weight [kg]	Max. operating speed [min ⁻¹]	Internal cooling	Specification	Order no.
d ₁	d ₂	d ₃	d ₄	l ₁								
40	16	38	14	60	3	12	42	0,4	26.000	-	ISM900-040-CA16-Z03R-AN_U12	31002240
50	22	48	18,5	70	4	20	52	0,7	23.000	-	ISM900-050-CA22-Z04R-AN_U12	31002241
63	27	60,6	20,5	75	4	20	52	1,2	21.000	-	ISM900-063-CA27-Z04R-AN_U12	31002242

Dimensions in mm.

The maximum operating speeds refer only to the cutting edge system.

ANMU

Radial indexable insert, four cutting edges







Workpiece material	P			M		K			
	Unalloyed Wear-resistant	Alloyed Tough/Ductile		Austenitic Wear-resistant	Ferritic Tough/Ductile	GJL Wear-resistant	GJS Tough/Ductile	GJL Wear-resistant	GJS Tough/Ductile
Substrate	Carbide			Carbide		Carbide			
Coating	PVD		CVD	PVD		PVD		CVD	
Cutting material type	HP975	HP980	HC775	HP980	HP985	HP965	HP975	HC760	HC770
Cutting edge design	M05	M03	M03	M03	M03	M05	M05	M05	M05
ANMU12	a_p max. [mm]								
ANMU120504R-	*	31029427					31029427		31218310
ANMU120508R-	*	30968178	31027000	31124584	31027000	31029429	31029430	30968178	31124582 31124583
Cutting edge design	U05	U03	U03	U03	U3	U05	U05	U05	U05
ANMU12	a_p max. [mm]								
ANMU120508R-	*	31253944	31253948	31273152	31253948	31290794	31273129	31253944	31273153 31253947

Feed per tooth

Application	Cutting edge design	Medium machining				Difficult conditions			
		M03		M05		U03		U05	
Coating	Edge rounding	PVD	CVD	PVD	CVD	PVD	CVD	PVD	CVD
		++	++	+++	+++	++	++	+++	+++
Feed/tooth [mm]	P	0.08 - 0.25	0.08 - 0.19	0.1 - 0.5	0.1 - 0.19	0.08 - 0.25	0.08 - 0.19	0.1 - 0.25	0.1 - 0.19
	M	0.08 - 0.2	0.08 - 0.15			0.08 - 0.2	0.08 - 0.15		
	K			0.1 - 0.3	0.1 - 0.23			0.1 - 0.3	0.1 - 0.23
	N								

Legend: ++ = medium rounded | +++ = heavily rounded

Accessories

	ANMU1205	Indexable inserts	Page 347
		Chuck for end milling cutter see MAPAL catalogue "CLAMPING"	
		Milling cutter arbor for milling cutter head see MAPAL catalogue "CLAMPING"	
		Milling cutter clamping screw for milling cutter head	Page 386

Spare parts**

	ANMU1205	Clamping screw for indexable insert TORX® M3x8.5-TX8-IP	Order no. 10105076
-------------------------------------------------------------------------------------	----------	---------------------------------------------------------	-----------------------

* a_p max. depends on the type of milling cutter and application.

** Included in scope of delivery.

For cutting data recommendations, see end of chapter.

TGMill-2-Shell

Shell end face milling cutter with tangential technology
CTHD09

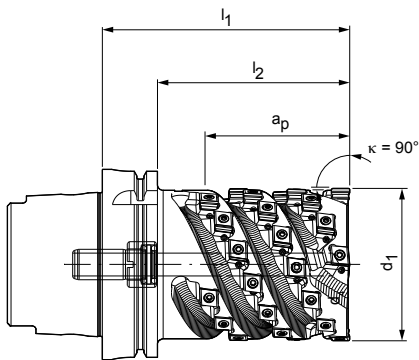



With connection HSK-A (hollow shank taper form A)

Dimensions				Z_{eff}	Number of indexable inserts	a_p max.	Weight [kg]	Max. operating speed [min^{-1}]	Internal cooling	Specification	Order no.
d_1	HSK-A nominal size	l_1	l_2								
63	100	130	100	3	30	75	3,9	20.000	✓	ISM901-063-A100-Z3R-CT_D09	30425932
80	100	130	100	4	40	75	5,3	20.000	✓	ISM901-080-A100-Z4R-CT_D09	30395633
100	100	130	100	4	40	75	6,8	20.000	✓	ISM901-100-A100-Z4R-CT_D09	30395638

Accessories

	CTHD09T3	Indexable inserts	Page 349
-------------------------------------------------------------------------------------	----------	-------------------	----------

Spare parts*

	CTHD09T3	Clamping screw for indexable insert TORX PLUS® M3.5x9.4-TX10-IP	Order no. 10007315
		Threaded pin M3x8-sw1.5 IKØ1.2	Order no. 30433620
	HSK-A connection	Coolant tube HSK100	Order no. 30326008

Dimensions in mm.

Other dimensions and mounting available upon request.

* Included in scope of delivery.

The maximum operating speeds refer to the cutting edge system.

CTHD

Tangential indexable inserts, double edge

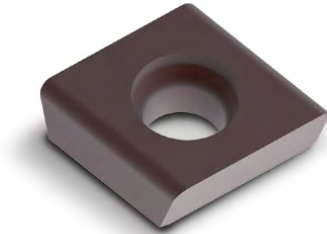

Workpiece material	N	
	Al alloyed ← Wear-resistant	Cu alloyed → Tough/Ductile
Substrate	Carbide	PCD
Coating	-	-
Cutting material type	HU616	PU617
Cutting edge design	D00	D80
CTHD09	a_p max. [mm]	
CTHD09T304...R-...	*	30029737
CTHD09T304...R90M018-...	*	30567180
CTHD09T308...R-...	*	30029738
CTHD09T312...R-...	*	30029739
Cutting edge design		D60
CTHD09	a_p max. [mm]	
CTHD09T304...R-...	2.5	31283617
CTHD09T304...R90M018-...	2.5	31283618
CTHD09T308...R-...	2.5	31283621

Feed per tooth

Application		Universal application		
		D00	D60	D80
Cutting edge design				
Edge rounding		0	0	0
Feed/tooth [mm]	P			
	M			
	K			
	N	0.05 - 0.5	0.05 - 0.5	0.05 - 0.5

Legend: 0 = sharp edged

* a_p max. depends on the type of milling cutter and application.
 For related clamping screw and screwdriver see page 385.
 For cutting data recommendations, see end of chapter.

TGMill-4-Shell

Shell end face milling cutter with tangential technology
CT_Q09

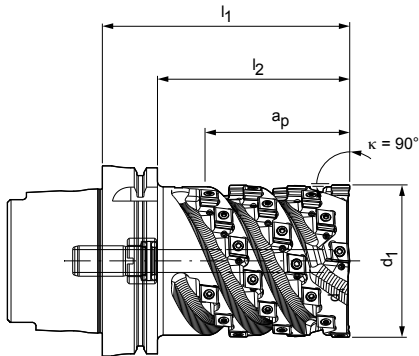

With connection HSK-A (hollow shank taper form A)

Dimensions				Z _{eff}	Number of indexable inserts	a _p max.	Weight [kg]	Max. operating speed [min ⁻¹]	Internal cooling	Specification	Order no.
d ₁	HSK-A nominal size	l ₁	l ₂								
63	100	130	100	4	40	75	4	20.000	✓	ISM901-063-A100-Z4R-CT_Q09	30395627
80	100	130	100	4	40	75	5,2	20.000	✓	ISM901-080-A100-Z4R-CT_Q09	30395634
100	100	130	100	5	50	75	6,9	20.000	✓	ISM901-100-A100-Z5R-CT_Q09	30395640

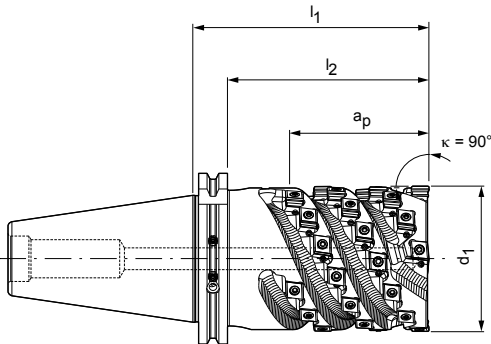



With connection shank taper

Dimensions				Z _{eff}	Number of indexable inserts	a _p max.	Weight [kg]	Max. operating speed [min ⁻¹]	Internal cooling	Specification	Order no.
d ₁	SK nominal size	l ₁	l ₂								
63	50	130	110	4	40	75	4,8	16.000	✓	ISM901-063-S050-Z4R-CT_Q09	30395631
80	50	130	110	4	40	75	6,0	16.000	✓	ISM901-080-S050-Z4R-CT_Q09	30395637
100	50	130	110	5	50	75	7,8	16.000	✓	ISM901-100-S050-Z5R-CT_Q09	30395642

Accessories

	CT_Q0905	Indexable inserts	Page 352
-------------------------------------------------------------------------------------	----------	-------------------	----------

Spare parts*

	CT_Q0905	Clamping screw for indexable insert TORX PLUS® M3.5x11-TX10-IP	Order no. 10105079
		Threaded pin M3x8-sw1.5 1Kø1.2	Order no. 30433620
	HSK-A connection	Coolant tube HSK100	Order no. 30326008

Dimensions in mm.

Tool body for aluminium machining available upon request.

* Included in scope of delivery.

The maximum operating speeds refer to the cutting edge system.

CUSTOM- MADE SHELL END FACE AND FORM MILLING CUTTER



Form milling cutter with a special geometry for pre-milling the blade root groove profile on a gas turbine for energy production. The blade root groove profile is used to subsequently join the turbine blades.

► Customised special solution upon request



CUSTOMISED SPECIAL SOLUTIONS

- Individual dimensions
- Different numbers of teeth
- Tool design with insert seats for tangential, radial and special inserts
- Milling cutter head or monolithic design with different connections
- Standard milling cutter arbor with vibration damper or customised tool body with integrated vibration damper

INSERTS IN SPECIAL DESIGN

- Special inserts with component-specific geometries and a large selection of cutting materials
- High process reliability in case of contour-dependent shapes and geometries
- Saves complex machining sequences, reducing cycle and non-productive times
- Multi-cutting-edge capability for manufacturing complex component-specific contours

CTHQ | CTNQ

Tangential indexable insert, four cutting edges

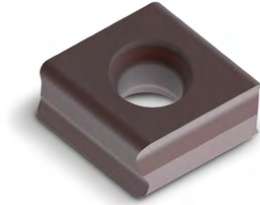

Workpiece material	P		M	
			Austenitic Ferritic Wear-resistant Tough/Ductile	
Substrate	Carbide		Carbide	
Coating	PVD	CVD	PVD	
Cutting material type	HP975	HC775	HP980	HP985

Cutting edge design		H08	H06	H06	H06
CTNQ09	<i>a_p max. [mm]</i>				
CTNQ090508...R-...	*	31048496	31272737	31048497	31048498
CTNQ090512...R-...	*	31048510	31272700	31048511	31048512
CTHQ09					
CTHQ090508...R-...	*	31048522	31272841	31048523	31048524
CTHQ090512...R-...	*	31048526	31272850	31048527	31048528

Cutting edge design		A38	A36	A36	A36
CTNQ09	<i>a_p max. [mm]</i>				
CTNQ090508...R-...	*	31048514	31272812	31048515	31048516
CTNQ090512...R-...	*	31048518	31272720	31048519	31048520
CTHQ09					
CTHQ090508...R-...	*	31048530	31272837	31048531	31048532
CTHQ090508...R90M008-...	*		31272835	31190733	
CTHQ090512...R-...	*	31048534	31272845	31048535	31048536

Feed per tooth

Application		Roughing					Medium machining				
		H06		H08		H21	A36		A38		H20
Cutting edge design		PVD	CVD	PVD	CVD	PVD	PVD	CVD	PVD	CVD	PVD
Coating		++		+++		+	++		+++		0
Edge rounding		++		+++		+	++		+++		0
Feed/tooth [mm]	P	0.12-0.3	0.12-0.23	0.12-0.35	0.12-0.27		0.1-0.25	0.1-0.19	0.12-0.25	0.12-0.19	
	M	0.1-0.3	0.1-0.23				0.12-0.25	0.12-0.19			
	K			0.12-0.4	0.12-0.3				0.1-0.3	0.1-0.23	
	N					0.15 - 0.35					0.1 - 0.3

Legend: 0 = sharp edged | + = slightly rounded | ++ = medium rounded | +++ = heavily rounded

* *a_p max.* depends on the type of milling cutter and application.
 For related clamping screw and screwdriver see page 385.
 For cutting data recommendations, see end of chapter.

K				N	
GJL ← Wear-resistant		GJS → Tough/Ductile		GJL ← Wear-resistant	
GJS → Tough/Ductile		GJS → Tough/Ductile		GJS → Tough/Ductile	
Carbide				Carbide	
PVD		CVD		-	PVD
HP965	HP975	HC760	HC770	HU616	HP615
H08	H08	H08	H08		H21
31048495	31048496	31272745	31272748		
31048499	31048510	31272705	31272707		
31048521	31048522	31272843	31272844		31257300
31048525	31048526	31272851	31272855		31316852
A38	A38	A38	A38	H20	
31048513	31048514	31272816	31272817		
31048517	31048518	31272725	31272726		
31048529	31048530	31272838	31272840	31316862	
				31316865	
31048533	31048534	31272847	31272848	31316863	

Cutting Data Recommendation for Shell End Face Milling Cutter

Feed and cutting speed

Shell end face milling cutter

MMG*		Workpiece material	Strength/hardness [N/mm ²] [HRC]	Cooling			
				MQL/Air	Dry	Coolant	
P	P1	P1.1 Structural, free-cutting, case hardened and heat-treated steels, non-alloy	< 700		✓		
		P1.2 Structural, free-cutting, case hardened and heat-treated steels, non-alloy	< 1200		✓		
	P2	P2.1 Nitrided, case hardened and heat-treated steels, alloy	< 900		✓		
		P2.2 Nitrided, case hardened and heat-treated steels, alloy	< 1400		✓		
	P3	P3.1 Tool, bearing, spring and high-speed steels**	< 800		✓		
		P3.2 Tool, bearing, spring and high-speed steels**	< 1000		✓		
		P3.3 Tool, bearing, spring and high-speed steels**	< 1500		✓		
	P4	P4.1 Stainless steels, ferritic and martensitic					
	P5	P5.1 Cast steel					
	P6	P6.1 Stainless cast steel, ferritic and martensitic					
M	M1	M1.1 Stainless steels, austenitic	< 700		✓		
		M1.2 Stainless steels, ferritic/austenitic (duplex)	< 1000				
	M2	M2.1 Stainless/heat-resistant cast steel, austenitic	< 700				
	M3	M3.1 Stainless cast steel, ferritic/austenitic (duplex)	< 1000				
K	K1	K1.1 Cast iron with lamellar graphite (grey cast iron), GJL	< 300		✓		
		K2.1 Cast iron with spheroidal graphite, GJS	< 500		✓		
	K2	K2.2 Cast iron with spheroidal graphite, GJS	500-800				
		K2.3 Cast iron with spheroidal graphite, GJS	> 800				
	K3	K3.1 Cast iron with spheroidal graphite, GJV; malleable cast iron, GJM	< 500				
		K3.2 Cast iron with spheroidal graphite, GJV; malleable cast iron, GJM	> 500				
N	N1	N1.1 Aluminium, non-alloy and alloy < 3 % Si				✓	
		N1.2 Aluminium, alloy ≤ 7 % Si				✓	
		N1.3 Aluminium, alloy > 7-12 % Si				✓	
		N1.4 Aluminium, alloy > 12 % Si				✓	
	N2	N2.1 Copper, non-alloy and low-alloy	< 300				✓
		N2.2 Copper, alloy	> 300				✓
		N2.3 Brass, bronze, gunmetal	< 1200				✓
	N3	N3.1 Graphite, > 8 µm					✓
		N3.2 Graphite, ≤ 8 µm					✓
	N4	N4.1 Plastic, thermoplastics					✓
N4.2 Plastic, thermosets						✓	
N4.3 Plastic, foams						✓	

* MAPAL machining groups

** If the alloy parts Cr, Mo, Ni, V, W in total > 8%, then select the next highest MAPAL machining group.

v _c [m/min] according to cutting material type and contact ratio a _e /D																			
Carbide PVD-coated										Carbide CVD-coated						Carbide - uncoated		PCD	
HP615		HP965		HP975		HP980		HP985		HC760		HC770		HC775		HU616		PU617	
> 0.6	< 0.6	> 0.6	< 0.6	> 0.6	< 0.6	> 0.6	< 0.6	> 0.6	< 0.6	> 0.6	< 0.6	> 0.6	< 0.6	> 0.6	< 0.6	> 0.6	< 0.6	> 0.6	< 0.6
				180	220	180	220					260	280						
				150	180	150	180					250	270	240	260				
				160	200	160	200					240	260	230	250				
						130	160							220	240				
						130	160												
						130	160												
						120	150												
						120	150												
						130	160												
						110	140												
						160	180	140	170										
						140	160	120	150										
								100	120										
								90	110										
		220	270	200	240					330	350	320	330						
		200	240	180	220					300	330	300	320						
		180	220	160	200							260	300						
		160	200	140	170							220	260						
		170	210	150	180					210	240	200	220						
		160	200	140	170					200	220	180	200						
700	700															500	500	2,000	2,000
400	480															300	360	1,500	1,800
300	360															230	280	1,200	1,440
270	330																	700	840
250	300															250	300	600	720
130	160															120	150	500	600
190	230															180	220	450	540
320	390															300	360		
320	390																		
220	270															300	360	500	600
210	260															250	300	400	480

The specified machining values are guide values.

The optimum data for the respective machining task should be determined during the test or machining.

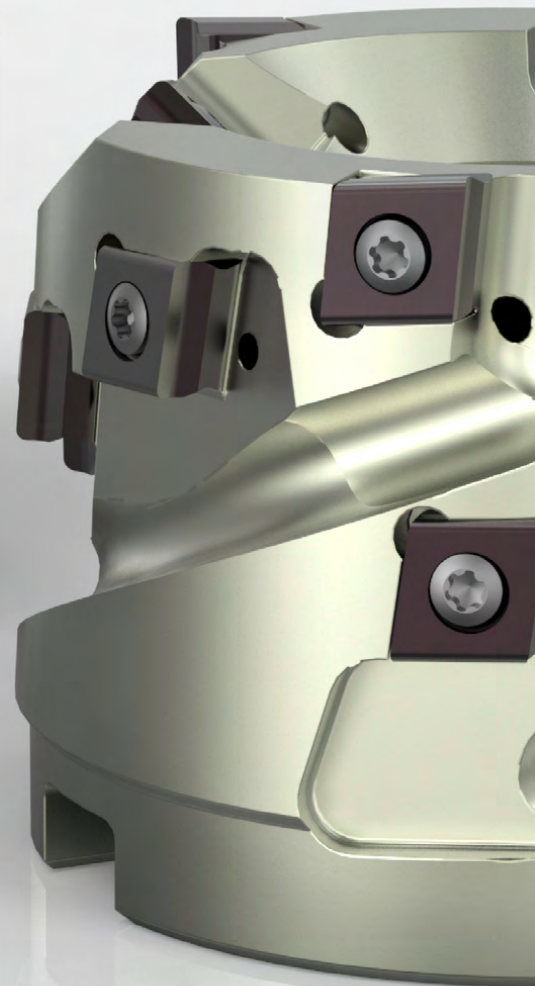



HELIX MILLING CUTTERS

TGMill – tangential technology

TGMill-2-Helical, CT_D09	358
TGMill-4-Helical, CT_Q09	360

Accessories and spare parts

Accessories for indexable inserts	385
Allocating milling cutter clamping screws	386

Technical appendix

Cutting data recommendations	364
Application notes Helix milling	400
Handling notes Milling cutter clamping screw	412

TGMill-2-Helical

Helix milling cutter with tangential technology, with integrated vibration damper
CT_D09

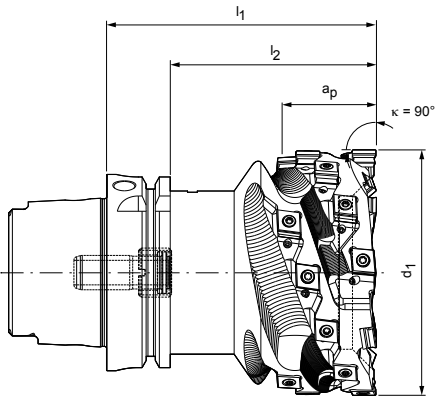



With connection HSK-A (hollow shank taper form A)

Dimensions				Z _{eff}	Number of indexable inserts	a _p max.	Weight [kg]	Max. operating speed [min ⁻¹]*	Internal cooling	Specification	Order no.
d ₁	HSK-A nominal size	l ₁	l ₂								
80	63	90	64	4	20+4	35	2,4	7.500	✓	IHM901-080-A063-Z4R-CT_D09	30395675
100	80	110	84	4	20+4	35	4,5	7.000	✓	IHM901-100-A080-Z4R-CT_D09	30395676
125	100	110	81	5	25+5	35	7,4	6.000	✓	IHM901-125-A100-Z5R-CT_D09	30395677

Accessories

	CT_D09T3	Indexable inserts	Page 359
-------------------------------------------------------------------------------------	----------	-------------------	----------

Spare parts**

	CT_D09T3	Clamping screw for indexable insert TORX PLUS® M3.5x9.4-TX10-IP	Order no. 10007315
		Threaded pin M3x8-sw1.5 IKØ1.2	Order no. 30433620
	HSK-A connection	Coolant tube HSK63 HSK80 HSK100	Order no. 30326006 30326007 30326008

Dimensions in mm.

Other dimensions and mounting available upon request.

* For nominal length l₁.

** Included in scope of delivery.

The maximum operating speeds refer to the insert system.

CTHD

Tangential indexable insert, double edge

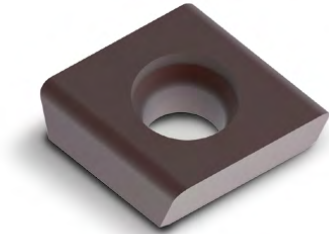

Workpiece material	N	
	Al alloyed ← Wear-resistant	Cu alloyed → Tough/Ductile
Substrate	Carbide	PCD
Coating	-	-
Cutting material type	HU616	PU617

Cutting edge design		D00	D80
CTHD09	a_p max. [mm]		
CTHD09T304...L-...	*	30029697	30492516
CTHD09T304...R-...	*	30029737	30492519
CTHD09T304...R90M018-...	*	30567180	31283626
CTHD09T308...L-...	*	30029698	30383869
CTHD09T308...R-...	*	30029738	30374036
CTHD09T312...L-...	*	30029699	
CTHD09T312...R-...	*	30029739	

Cutting edge design		D60
CTHD09	a_p max. [mm]	
CTHD09T304...L-...	2.5	31283606
CTHD09T304...R-...	2.5	31283617
CTHD09T304...R90M018-...	2.5	31283618
CTHD09T308...L-...	2.5	31283620
CTHD09T308...R-...	2.5	31283621

Feed per tooth

Application		Universal application		
		D00	D60	D80
Cutting edge design		0	0	0
Edge rounding		0	0	0
Feed/tooth [mm]	P			
	M			
	K			
	N	0.05 - 0.5	0.05 - 0.5	0.05 - 0.5

Legend: 0 = sharp edged

Assembly note

d_1	Number of indexable inserts	Right design	Left design
80	20+4	20	4
100	20+4	20	4
125	25+5	25	5
140	25+5	25	5
160	30+6	30	6

* a_p max. depends on the type of milling cutter and application.
 For related clamping screw and screwdriver see page 385.
 For cutting data recommendations, see end of chapter.

TGMill-4-Helical

Helix milling cutter with tangential technology, with integrated vibration damper
CT_Q09

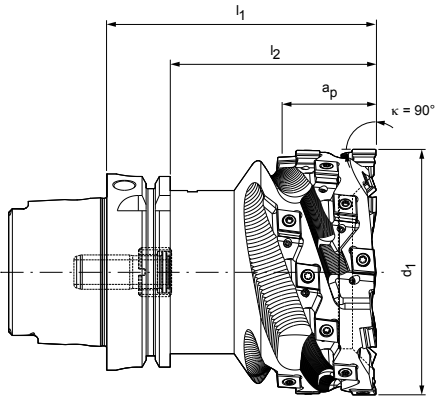



With connection HSK-A (hollow shank taper form A)

Dimensions				Z _{eff}	Number of indexable inserts	a _p max.	Weight [kg]	Max. operating speed [min ⁻¹]*	Internal cooling	Specification	Order no.
d ₁	HSK-A nominal size	l ₁	l ₂								
80	63	90	64	4	20+4	35	2,4	7.500	✓	IHM901-080-A063-Z4R-CT_Q09	30346711
100	80	110	84	4	20+4	35	4,6	7.000	✓	IHM901-100-A080-Z4R-CT_Q09	30346712
125	100	110	81	5	25+5	35	7,6	6.000	✓	IHM901-125-A100-Z5R-CT_Q09	30340468

Accessories

	CT_Q0905	Indexable inserts	Page 362
-------------------------------------------------------------------------------------	----------	-------------------	----------

Spare parts**

	CT_Q0905	Clamping screw for indexable insert TORX PLUS® M3.5x11-TX10-IP	Order no. 10105079
		Threaded pin M3x8-sw1.5 IKØ1.2	Order no. 30433620
	HSK-A connection	Coolant tube HSK63 HSK80 HSK100	Order no. 30326006 30326007 30326008

Assembly note

d ₁	Number of indexable inserts	Right design	Left design
100	20+4	20	4
125	25+5	25	5

Dimensions in mm.
Additional dimensions and mounting versions available upon request.
Tool body for aluminium machining available upon request.
* For nominal length l₁.
** Included in scope of delivery.
The maximum operating speeds refer to the cutting edge system.

CUSTOM-MADE HELIX MILLING CUTTER



Helix milling cutter with integrated vibration damper, tangential technology and HSK extension for pre-milling the outer diameter at joints of the stator carrier of an electric motor. This allows standard extensions to be used without vibration dampers.

► Customised special solution upon request

CUSTOMISED SPECIAL SOLUTIONS

- Individual dimensions
- Different numbers of teeth
- Tool design with insert seats for tangential, radial and special inserts
- Monolithic design with integrated vibration damper for the use of standard extensions without integrated vibration dampening

INSERTS IN SPECIAL DESIGN

- Special inserts with component-specific geometries and a large selection of cutting materials
- High process reliability in case of contour-dependent shapes and geometries
- Saves complex machining sequences, reducing cycle and non-productive times
- Multi-cutting-edge capability for manufacturing complex component-specific contours

CTHQ | CTNQ

Tangential indexable insert, four cutting edges

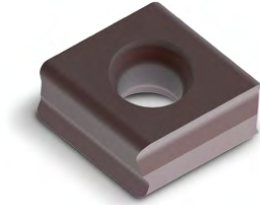

Workpiece material	P		M	
			Austenitic Wear-resistant	Ferritic Tough/Ductile
Substrate	Carbide		Carbide	
Coating	PVD	CVD	PVD	
Cutting material type	HP975	HC775	HP980	HP985

Cutting edge design		H08	H06	H06	H06
CTNQ09	a_p max. [mm]				
CTNQ090508...L-...	*	31190836	31272736	31190839	31190850
CTNQ090508...R-...	*	31048496	31272737	31048497	31048498
CTNQ090512...L-...	*	31190854	31272688	31190857	31190860
CTNQ090512...R-...	*	31048510	31272700	31048511	31048512
CTHQ09					
CTHQ090508...R-...	*	31048522	31272841	31048523	31048524
CTHQ090512...R-...	*	31048526	31272850	31048527	31048528

Cutting edge design		A38	A36	A36	A36
CTNQ09	a_p max. [mm]				
CTNQ090508...L-...	*	31190866	31272811	31190868	31190870
CTNQ090508...R-...	*	31048514	31272812	31048515	31048516
CTNQ090512...L-...	*	31190872	31272709	31190874	31190875
CTNQ090512...R-...	*	31048518	31272720	31048519	31048520
CTHQ09					
CTHQ090508...R-...	*	31048530	31272837	31048531	31048532
CTHQ090508...R90M008-...	*		31272835	31190733	
CTHQ090512...R-...	*	31048534	31272845	31048535	31048536

Feed per tooth

Application		Roughing					Medium machining				
		H06		H08		H21	A36		A38		H20
Cutting edge design		PVD	CVD	PVD	CVD	PVD	PVD	CVD	PVD	CVD	PVD
Coating											
Edge rounding		++		+++		+	++		+++		0
Feed/tooth [mm]	P	0.12-0.3	0.12-0.23	0.12-0.35	0.12-0.27		0.1-0.25	0.1-0.19	0.12-0.25	0.12-0.19	
	M	0.1-0.3	0.1-0.23				0.12-0.25	0.12-0.19			
	K			0.12-0.4	0.12-0.3				0.1-0.3	0.1-0.23	
	N					0.15 - 0.35					0.1 - 0.3

Legend: 0 = sharp edged | + = slightly rounded | ++ = medium rounded | +++ = heavily rounded

* a_p max. depends on the type of milling cutter and application.
 For related clamping screw and screwdriver see page 385.
 For cutting data recommendations, see end of chapter.

K				N	
GJL ← Wear-resistant		GJS → Tough/Ductile		GJL ← Wear-resistant	
GJS → Tough/Ductile		GJS → Tough/Ductile			
Carbide				Carbide	
PVD		CVD		-	PVD
HP965	HP975	HC760	HC770	HU616	HP615
H08	H08	H08	H08		H21
31190831	31190836	31272741	31272744		
31048495	31048496	31272745	31272748		
31190852	31190854	31272702	31272703		
31048499	31048510	31272705	31272707		
31048521	31048522	31272843	31272844		31257300
31048525	31048526	31272851	31272855		31316852
A38	A38	A38	A38	H20	
31190864	31190866	31272813	31272815		
31048513	31048514	31272816	31272817		
31190871	31190872	31272722	31272723		
31048517	31048518	31272725	31272726		
31048529	31048530	31272838	31272840	31316862	
				31316865	
31048533	31048534	31272847	31272848	31316863	

Cutting data recommendations for helix milling cutter

Feed and cutting speed

Helix milling cutters

MMG*		Workpiece material	Strength/hardness [N/mm ²] [HRC]	Cooling			
				MQL/Air	Dry	Coolant	
P	P1	P1.1 Structural, free-cutting, case hardened and heat-treated steels, non-alloy	< 700		✓		
		P1.2 Structural, free-cutting, case hardened and heat-treated steels, non-alloy	< 1200		✓		
	P2	P2.1 Nitrided, case hardened and heat-treated steels, alloy	< 900		✓		
		P2.2 Nitrided, case hardened and heat-treated steels, alloy	< 1400		✓		
	P3	P3.1 Tool, bearing, spring and high-speed steels**	< 800		✓		
		P3.2 Tool, bearing, spring and high-speed steels**	< 1000		✓		
		P3.3 Tool, bearing, spring and high-speed steels**	< 1500		✓		
	P4	P4.1 Stainless steels, ferritic and martensitic					
	P5	P5.1 Cast steel					
	P6	P6.1 Stainless cast steel, ferritic and martensitic					
M	M1	M1.1 Stainless steels, austenitic	< 700		✓		
		M1.2 Stainless steels, ferritic/austenitic (duplex)	< 1000				
	M2	M2.1 Stainless/heat-resistant cast steel, austenitic	< 700				
	M3	M3.1 Stainless cast steel, ferritic/austenitic (duplex)	< 1000				
K	K1	K1.1 Cast iron with lamellar graphite (grey cast iron), GJL	< 300		✓		
		K2.1 Cast iron with spheroidal graphite, GJS	< 500		✓		
	K2	K2.2 Cast iron with spheroidal graphite, GJS	500-800				
		K2.3 Cast iron with spheroidal graphite, GJS	> 800				
	K3	K3.1 Cast iron with spheroidal graphite, GJV; malleable cast iron, GJM	< 500				
		K3.2 Cast iron with spheroidal graphite, GJV; malleable cast iron, GJM	> 500				
N	N1	N1.1 Aluminium, non-alloy and alloy < 3 % Si				✓	
		N1.2 Aluminium, alloy ≤ 7 % Si				✓	
		N1.3 Aluminium, alloy > 7-12 % Si				✓	
		N1.4 Aluminium, alloy > 12 % Si				✓	
	N2	N2.1 Copper, non-alloy and low-alloy	< 300				✓
		N2.2 Copper, alloy	> 300				✓
		N2.3 Brass, bronze, gunmetal	< 1200				✓
	N3	N3.1 Graphite, > 8 µm					✓
		N3.2 Graphite, ≤ 8 µm					✓
	N4	N4.1 Plastic, thermoplastics					✓
		N4.2 Plastic, thermosets					✓
		N4.3 Plastic, foams					✓

* MAPAL machining groups

** If the alloy parts Cr, Mo, Ni, V, W in total > 8%, then select the next highest MAPAL machining group.

v _c [m/min] according to cutting material type and contact ratio a _e /D																			
Carbide PVD-coated										Carbide CVD-coated						Carbide - uncoated		PCD	
HP615		HP965		HP975		HP980		HP985		HC760		HC770		HC775		HU616		PU617	
> 0.6	< 0.6	> 0.6	< 0.6	> 0.6	< 0.6	> 0.6	< 0.6	> 0.6	< 0.6	> 0.6	< 0.6	> 0.6	< 0.6	> 0.6	< 0.6	> 0.6	< 0.6	> 0.6	< 0.6
				180	220	180	220					260	280						
				150	180	150	180					250	270	240	260				
				160	200	160	200					240	260	230	250				
						130	160							220	240				
						130	160												
						130	160												
						120	150												
						120	150												
						130	160												
						110	140												
						160	180	140	170										
						140	160	120	150										
								100	120										
								90	110										
		220	270	200	240					330	350	320	330						
		200	240	180	220					300	330	300	320						
		180	220	160	200							260	300						
		160	200	140	170							220	260						
		170	210	150	180					210	240	200	220						
		160	200	140	170					200	220	180	200						
700	700															500	500	2000	2000
400	480															300	360	1500	1800
300	360															230	280	1200	1440
270	330																	700	840
250	300															250	300	600	720
130	160															120	150	500	600
190	230															180	220	450	540
320	390															300	360		
320	390																		
220	270															300	360	500	600
210	260															250	300	400	480

The specified machining values are guide values.
 The optimum data for the respective machining task should be determined during the test or machining.

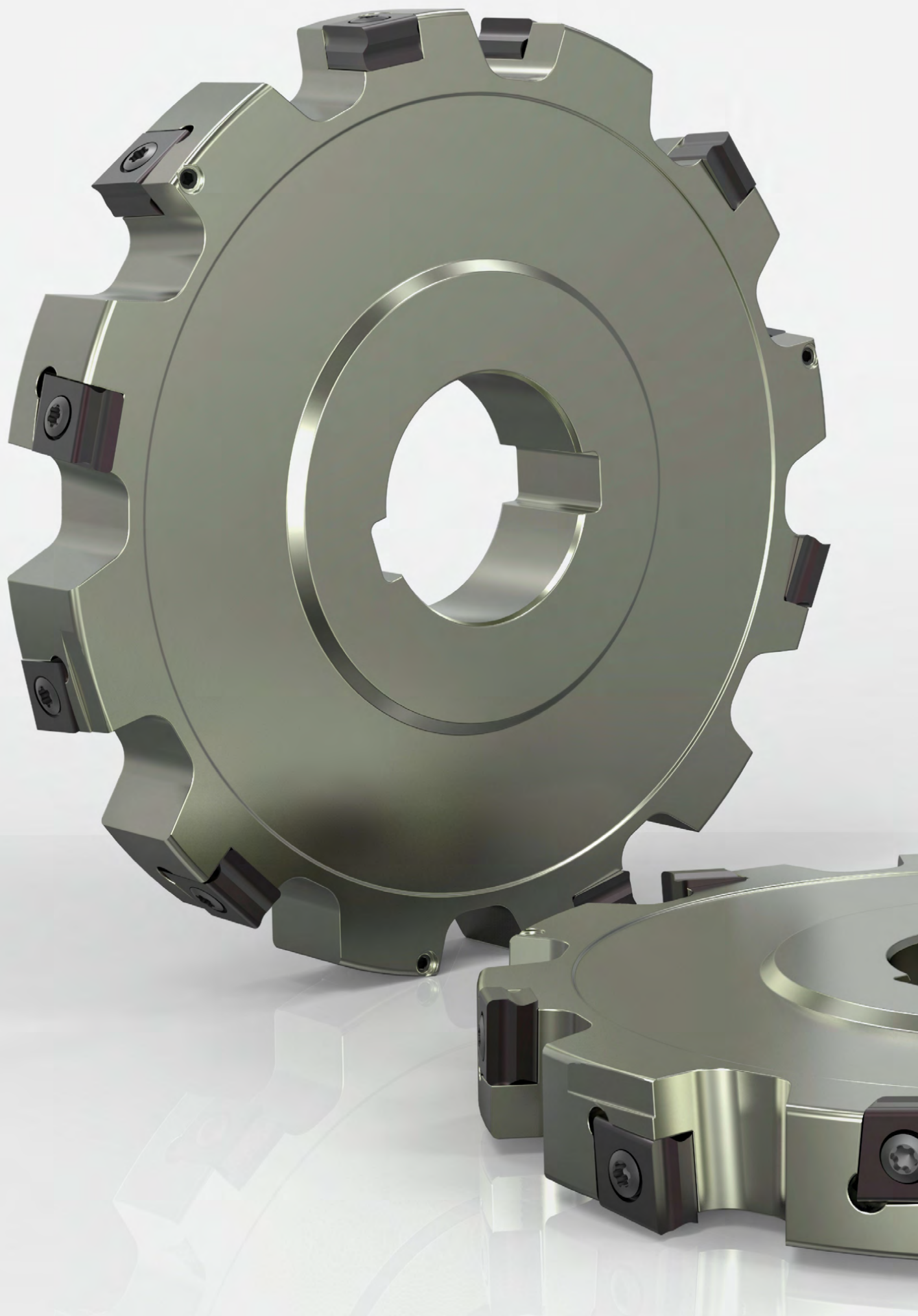

DISC MILLING CUTTER

TGMill – tangential technology

TGMill-2-Disc, CT_D09	368
TGMill-4-Disc, CT_Q09	370

Accessories and spare parts

Accessories for tangential indexable inserts	385
Allocating milling cutter clamping screws	386

Technical appendix

Cutting data recommendations	374
Handling notes Milling cutter clamping screw	412

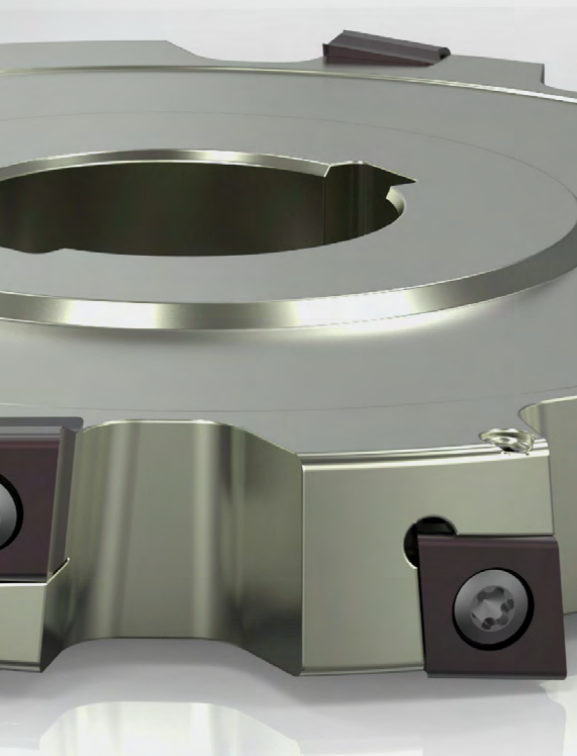

TGMill-2-Disc

Disc milling cutter with tangential technology



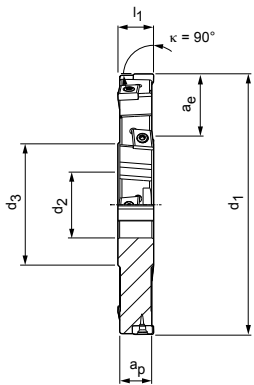

CT_D09





Milling cutter head, both sides – triple edge

Dimensions				Z _{eff}	Z _{axial} *	Number of indexable inserts	a _p max.	a _e max.	Weight [kg]	Max. operating speed [min ⁻¹]	Internal cooling	Specification	Order no.
d ₁	d ₂	d ₃	l ₁										
100	32	58	17	5+5	2+2	10	17	18	0,7	27.000	–	IDM900-100-CA32-Z5+5R3-CT_D09	30395685
125	32	58	17	6+6	3+3	12	17	30	1,2	24.100	–	IDM900-125-CA32-Z6+6R3-CT_D09	30383557
160	40	70	17	7+7	3+3	14	17	40	2	21.300	–	IDM900-160-CA40-Z7+7R3-CT_D09	30395701
200	40	70	17	8+8	4+4	16	17	60	3,3	19.100	–	IDM900-200-CA40-Z8+8R3-CT_D09	30395712

Accessories

	CTHD09T3	Indexable inserts	Page 369
		Milling cutter arbor for milling cutter head see MAPAL catalogue "CLAMPING"	
		Spacer ring	Page 383
		Milling cutter clamping screw for milling cutter head	Page 386

Spare parts**

	CT_D09T3	TORX PLUS® M3.5x9.4-TX10-IP	Order no. 10007315
	CT_D09T3	Threaded pin ISO 4026 – M3X5-45H	Order no. 10003421

Dimensions in mm.

Other dimensions for one-sided cutting (left or right side) available upon request.

* Number of axially adjustable indexable inserts.

** Included in scope of delivery.

The maximum operating speeds refer to the cutting edge system.

CTHD

Tangential indexable insert, double edge or single edge (tipped)



Workpiece material	N	
	Al alloyed ← Wear-resistant	Cu alloyed → Tough/Ductile
Substrate	Carbide	PCD
Coating	-	-
Cutting material type	HU616	PU617

Cutting edge design		D00	D80
CTHD09	a_p max. [mm]		
CTHD09T304...L-...	*	30029697	30492516
CTHD09T304...L90M018-...	*	30493152	31283623
CTHD09T304...R-...	*	30029737	30492519
CTHD09T304...R90M018-...	*	30567180	31283626
CTHD09T308...L-...	*	30029698	30383869
CTHD09T308...R-...	*	30029738	30374036
CTHD09T312...L-...	*	30029699	
CTHD09T312...R-...	*	30029739	

Cutting edge design		D60
CTHD09	a_p max. [mm]	
CTHD09T304...L-...	2.5	31283606
CTHD09T304...L90M018-...	2.5	31283614
CTHD09T304...R-...	2.5	31283617
CTHD09T304...R90M018-...	2.5	31283618
CTHD09T308...L-...	2.5	31283620
CTHD09T308...R-...	2.5	31283621

Feed per tooth

Application		Universal application		
		D00	D60	D80
Edge rounding		0	0	0
Feed/tooth [mm]	P			
	M			
	K			
	N	0.05 - 0.5	0.05 - 0.5	0.05 - 0.5

Legend: 0 = sharp edged

* a_p max. depends on the type of milling cutter and application.
 For related clamping screw and screwdriver see page 385.
 For cutting data recommendations, see end of chapter.

TGMill-4-Disc

Disc milling cutter with tangential technology



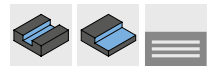
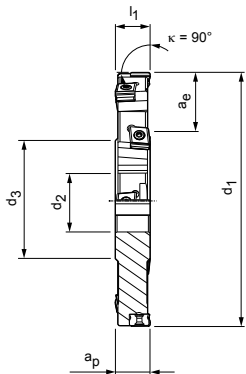

CT_Q09



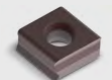

Milling cutter head, both sides – triple edge

Dimensions				Z _{eff}	Z _{axial} *	Number of indexable inserts	a _p max.	a _e max.	Weight [kg]	Max. operating speed [min ⁻¹]	Internal cooling	Specification	Order no.
d ₁	d ₂	d ₃	l ₁										
100	32	58	17	5+5	2+2	10	17	18	0,7	24.000	–	IDM900-100-CA32-Z5+5R3-CT_Q09	30395690
125	32	58	17	6+6	3+3	12	17	30	1,2	21.600	–	IDM900-125-CA32-Z6+6R3-CT_Q09	30382216
160	40	70	17	7+7	3+3	14	17	40	2	19.000	–	IDM900-160-CA40-Z7+7R3-CT_Q09	30395704
200	40	70	17	8+8	4+4	16	17	60	3,2	17.000	–	IDM900-200-CA40-Z8+8R3-CT_Q09	30395717

Accessories

	CT_Q0905	Indexable inserts	Page 372
		Milling cutter arbor for milling cutter head see MAPAL catalogue "CLAMPING"	
		Spacer ring	Page 383
		Milling cutter clamping screw for milling cutter head	Page 386

Spare parts**

	CT_Q0905	TORX PLUS® M3.5x11-TX10-IP	Order no. 10105079
		Threaded pin ISO 4026 – M3X5-45H	Order no. 10003421

Dimensions in mm.

Other dimensions for one-sided cutting (left or right side) available upon request.

* Number of axially adjustable indexable inserts.

** Included in scope of delivery.

The maximum operating speeds refer to the cutting edge system.



CUSTOM-MADE DISC MILLING CUTTER



Combination disc milling cutter and insert drill for machining wheel carriers or swivel bearings with less tools.

► Customised special solution upon request

CUSTOMISED SPECIAL SOLUTIONS

- Individual dimensions
- Different numbers of teeth
- Tool design with insert seats for tangential, radial and special inserts
- Milling cutter head or monolithic design with different connections
- Standard milling cutter arbor with vibration damper or customised tool body with integrated vibration damper

INSERTS IN SPECIAL DESIGN

- Special inserts with component-specific geometries and a large selection of cutting materials
- High process reliability in case of contour-dependent shapes and geometries
- Saves complex machining sequences, reducing cycle and non-productive times
- Multi-cutting-edge capability for manufacturing complex component-specific contours



Disc milling cutters with PCD-tipped cutting edges for the economical machining of optical components.

► Customised special solution upon request



CTHQ | CTNQ

Tangential indexable insert, four cutting edges

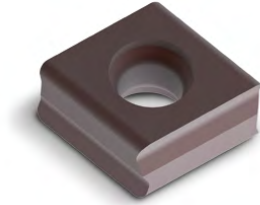

Workpiece material	P		M	
	Unalloyed Wear-resistant	Alloyed Tough/Ductile	Austenitic Wear-resistant	Ferritic Tough/Ductile
Substrate	Carbide		Carbide	
Coating	PVD		CVD	
Cutting material type	HP975		HC775	
			HP980	HP985

Cutting edge design		H08		H06	H06	H06
CTNQ09	<i>a_p max. [mm]</i>					
CTNQ090508...L-...	*	31190836		31272736	31190839	31190850
CTNQ090508...R-...	*	31048496		31272737	31048497	31048498
CTNQ090512...L-...	*	31190854		31272688	31190857	31190860
CTNQ090512...R-...	*	31048510		31272700	31048511	31048512
CTHQ09						
CTHQ090508...R-...	*	31048522		31272841	31048523	31048524
CTHQ090512...R-...	*	31048526		31272850	31048527	31048528

Cutting edge design		A38	A36	A36	A36	A36
CTNQ09	<i>a_p max. [mm]</i>					
CTNQ090508...L-...	*	31190866		31272811	31190868	31190870
CTNQ090508...R-...	*	31048514		31272812	31048515	31048516
CTNQ090512...L-...	*	31190872		31272709	31190874	31190875
CTNQ090512...R-...	*	31048518		31272720	31048519	31048520
CTHQ09						
CTHQ090508...L90M008-...	*		31190742	31272830	31190744	
CTHQ090508...R-...	*	31048530		31272837	31048531	31048532
CTHQ090508...R90M008-...	*		31190731	31272835	31190733	
CTHQ090512...R-...	*	31048534		31272845	31048535	31048536

Feed per tooth

Application	Cutting edge design	Roughing					Medium machining				
		H06		H08		H21	A36		A38		H20
Coating	Edge rounding	PVD	CVD	PVD	CVD	PVD	PVD	CVD	PVD	CVD	PVD
		++		+++		+	++		+++		0
Feed/tooth [mm]	P	0.12-0.3	0.12-0.23	0.12-0.35	0.12-0.27		0.1-0.25	0.1-0.19	0.12-0.25	0.12-0.19	
	M	0.1-0.3	0.1-0.23				0.12-0.25	0.12-0.19			
	K			0.12-0.4	0.12-0.3				0.1-0.3	0.1-0.23	
	N					0.15 - 0.35					0.1 - 0.3

Legend: 0 = sharp edged | + = slightly rounded | ++ = medium rounded | +++ = heavily rounded

* *a_p max.* depends on the type of milling cutter and application.
 For related clamping screw and screwdriver see page 385.
 For cutting data recommendations, see end of chapter.

K								N	
GJL ← Wear-resistant		GJS → Tough/Ductile		GJL ← Wear-resistant		GJS → Tough/Ductile			
Carbide								Carbide	
PVD				CVD				-	PVD
HP965		HP975		HC760		HC770		HU616	HP615
	H08		H08		H08		H08		H21
	31190831		31190836		31272741		31272744		
	31048495		31048496		31272745		31272748		
	31190852		31190854		31272702		31272703		
	31048499		31048510		31272705		31272707		
	31048521		31048522		31272843		31272844		31257300
	31048525		31048526		31272851		31272855		31316852
	A38	A36	A38	A36	A38	A36	A38	A36	H20
	31190864		31190866		31272813		31272815		
	31048513		31048514		31272816		31272817		
	31190871		31190872		31272722		31272723		
	31048517		31048518		31272725		31272726		
		31190740		31190742		31272818		31272819	
	31048529		31048530		31272838		31272840		31316862
		31190730		31190731		31272832		31272834	31316865
	31048533		31048534		31272847		31272848		31316863

Cutting data recommendations for disc milling cutter

Feed and cutting speed

Disc milling cutters

MMG*		Workpiece material	Strength/hardness [N/mm ²] [HRC]	Cooling			
				MQL/Air	Dry	Coolant	
P	P1	P1.1 Structural, free-cutting, case hardened and heat-treated steels, non-alloy	< 700		✓		
		P1.2 Structural, free-cutting, case hardened and heat-treated steels, non-alloy	< 1200		✓		
	P2	P2.1 Nitrided, case hardened and heat-treated steels, alloy	< 900		✓		
		P2.2 Nitrided, case hardened and heat-treated steels, alloy	< 1400		✓		
	P3	P3.1 Tool, bearing, spring and high-speed steels**	< 800		✓		
		P3.2 Tool, bearing, spring and high-speed steels**	< 1000		✓		
		P3.3 Tool, bearing, spring and high-speed steels**	< 1500		✓		
	P4	P4.1 Stainless steels, ferritic and martensitic					
	P5	P5.1 Cast steel					
	P6	P6.1 Stainless cast steel, ferritic and martensitic					
M	M1	M1.1 Stainless steels, austenitic	< 700		✓		
		M1.2 Stainless steels, ferritic/austenitic (duplex)	< 1000				
	M2	M2.1 Stainless/heat-resistant cast steel, austenitic	< 700				
	M3	M3.1 Stainless cast steel, ferritic/austenitic (duplex)	< 1000				
K	K1	K1.1 Cast iron with lamellar graphite (grey cast iron), GJL	< 300		✓		
		K2.1 Cast iron with spheroidal graphite, GJS	< 500		✓		
	K2	K2.2 Cast iron with spheroidal graphite, GJS	500-800				
		K2.3 Cast iron with spheroidal graphite, GJS	> 800				
	K3	K3.1 Cast iron with spheroidal graphite, GJV; malleable cast iron, GJM	< 500				
		K3.2 Cast iron with spheroidal graphite, GJV; malleable cast iron, GJM	> 500				
N	N1	N1.1 Aluminium, non-alloy and alloy < 3 % Si				✓	
		N1.2 Aluminium, alloy ≤ 7 % Si				✓	
		N1.3 Aluminium, alloy > 7-12 % Si				✓	
		N1.4 Aluminium, alloy > 12 % Si				✓	
	N2	N2.1 Copper, non-alloy and low-alloy	< 300				✓
		N2.2 Copper, alloy	> 300				✓
		N2.3 Brass, bronze, gunmetal	< 1200				✓
	N3	N3.1 Graphite, > 8 µm					✓
		N3.2 Graphite, ≤ 8 µm					✓
	N4	N4.1 Plastic, thermoplastics					✓
N4.2 Plastic, thermosets						✓	
N4.3 Plastic, foams						✓	

* MAPAL machining groups

** If the alloy parts Cr, Mo, Ni, V, W in total > 8%, then select the next highest MAPAL machining group.

v _c [m/min] according to cutting material type and contact ratio a _e /D																			
Carbide PVD-coated										Carbide CVD-coated						Carbide uncoated		PCD	
HP615		HP965		HP975		HP980		HP985		HC760		HC770		HC775		HU616		PU617	
> 0.6	< 0.6	> 0.6	< 0.6	> 0.6	< 0.6	> 0.6	< 0.6	> 0.6	< 0.6	> 0.6	< 0.6	> 0.6	< 0.6	> 0.6	< 0.6	> 0.6	< 0.6	> 0.6	< 0.6
				180	220	180	220					260	280						
				150	180	150	180					250	270	240	260				
				160	200	160	200					240	260	230	250				
						130	160							220	240				
						130	160												
						130	160												
						120	150												
						120	150												
						130	160												
						110	140												
						160	180	140	170										
						140	160	120	150										
								100	120										
								90	110										
		220	270	200	240					330	350	320	330						
		200	240	180	220					300	330	300	320						
		180	220	160	200							260	300						
		160	200	140	170							220	260						
		170	210	150	180					210	240	200	220						
		160	200	140	170					200	220	180	200						
700	700															500	500	2000	2000
400	480															300	360	1500	1800
300	360															230	280	1200	1440
270	330																	700	840
250	300															250	300	600	720
130	160															120	150	500	600
190	230															180	220	450	540
320	390															300	360		
320	390																		
220	270															300	360	500	600
210	260															250	300	400	480

The specified machining values are guide values.
The optimum data for the respective machining task should be determined during the test or machining.





ACCESSORIES AND SPARE PARTS

Milling cutter with PCD milling cartridges

Power milling head system	378
Eco milling head system	380

Milling cutter with indexable inserts

Accessories and spare parts	382
Allocating milling cutter clamping screws	386



General accessories

Screwdriver	388
Torque wrench set, screwdriver set	389

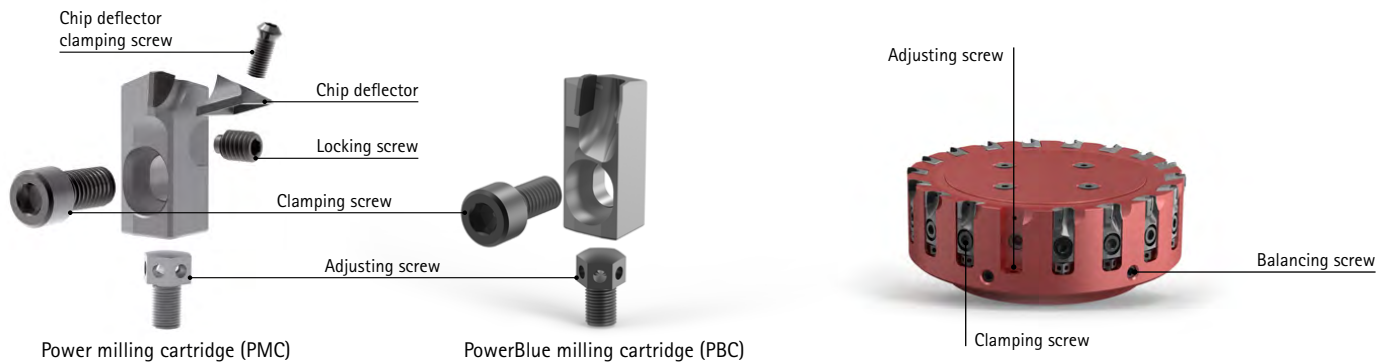

Accessories and spare parts for milling cutters with PCD milling cartridges – Power system



	PMC	PBC	d* [mm]	Dimension	Description	Wrench size / Torx size	Tightening torque [Nm]	Weight [g]	Order no.
Clamping screws for milling cartridge									
	•	•	50 - 400	M6x13	Cylinder head screw	SW 5	14	5	30696520**
Adjusting screw for milling cartridge									
	•	•	50 - 400	M5x8				2,5	30696523
Balancing screws									
	•	•	50 - 100	M6x10	Balancing screw			1,4	10012533
	•	•	125 - 400	M8x10	Balancing screw			2,7	10012538

* Face milling cutter diameter.

** Only suitable for single use.

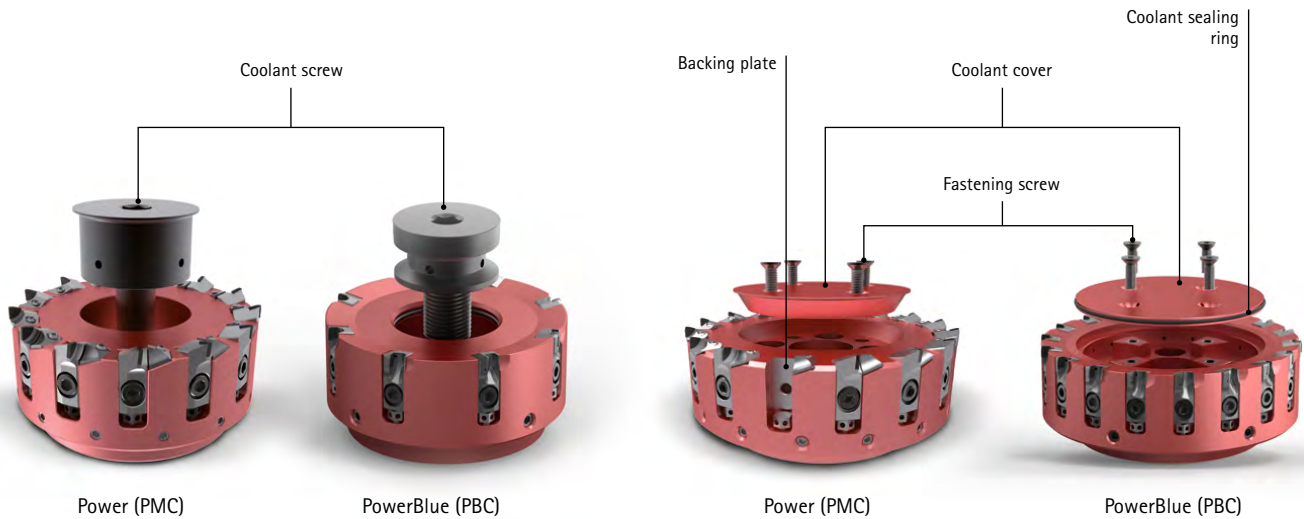





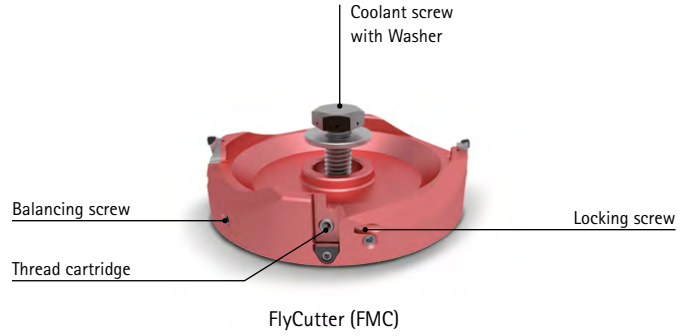
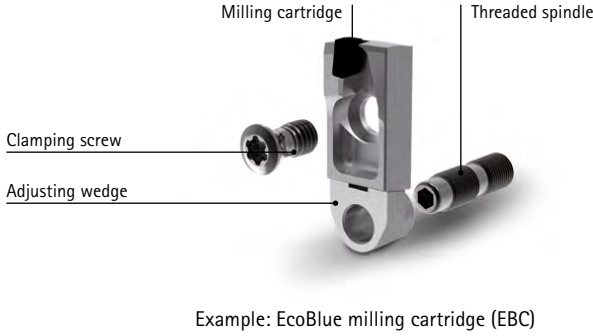

	PMC	PBC	d* [mm]	Dimension	Description	Wrench size / Torx size	Tightening torque [Nm]	Weight [g]	Order no.
Fastening screw with coolant delivery									
	•		50		Coolant screw	SW 8	20	33,6	30430829
	•		63		Coolant screw	SW 10	50	82,3	30326178
	•		80		Coolant screw	SW 12	80	176,2	30326179
	•		100		Coolant screw	SW 14	100	263	30326180
	•		125 - 140		Coolant screw	SW 14	200	595	30326181
		•	50		Coolant screw	SW 8	20	197	30543340
		•	63		Coolant screw	SW 10	50	69,4	30543341
		•	80		Coolant screw	SW 12	80	128,3	30543342
		•	100		Coolant screw	SW 14	100	203,5	30543344
		•	125 - 140		Coolant screw	SW 14	200	460	30543345
Coolant cover									
	•		160 - 180		Coolant cover			200	30696538
	•		200		Coolant cover			500	30696539
	•		250		Coolant cover			700	30696540
	•		315		Coolant cover			1300	30696541
	•		400		Coolant cover			2300	30696542
Coolant cover including coolant sealing ring									
		•	160		Coolant cover			140,4	30569889
		•	200		Coolant cover			256,2	30569890
		•	250		Coolant cover			540,2	30569891
		•	315		Coolant cover			940	30569892
		•	400		Coolant cover			1550	30569893
Fastening screw for coolant cover									
	•	•	160 - 400	M6x18	Countersunk screw	SW 4		4,3	30670137
Accessories**									
Fastening screw for milling cutter arbors									
	•	•	160	M12x45	Cylinder head screw in acc. with ISO 4762	SW 10	70	84	10006594
	•	•	200 - 400	M16x50	Cylinder head screw in acc. with ISO 4762	SW 14	70	140	10007775

* Face milling cutter diameter.

** Not included in scope of delivery.

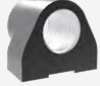





Accessories and spare parts for milling cutters with PCD milling cartridges – Eco system

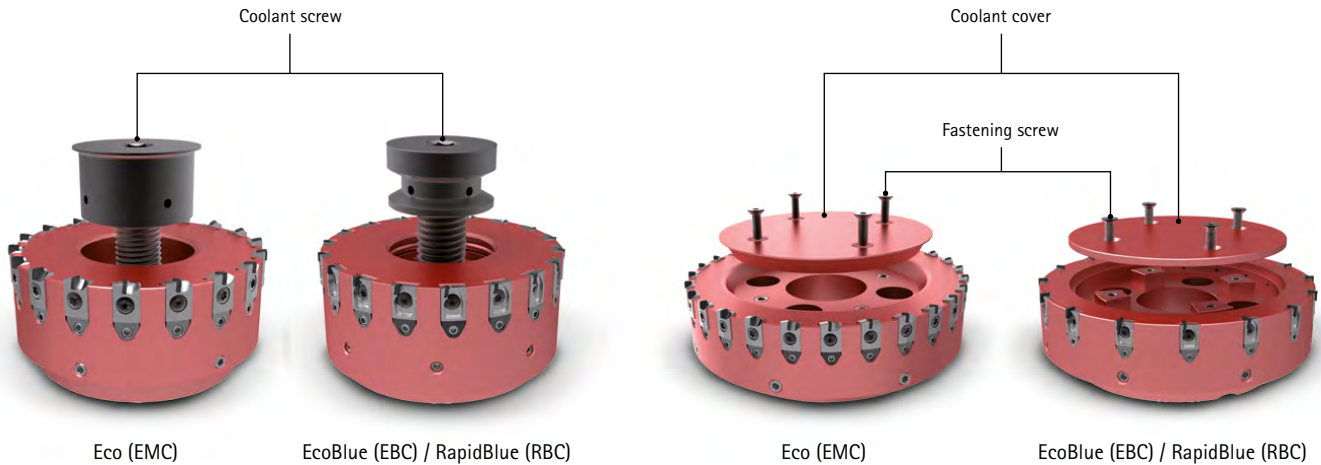

	EMC	EBC	RBC	FMC	d* [mm]	Di mensions	Description	SW / Torx size	Tightening torque [Nm]	Weight [g]	Order no.
Clamping screws for milling cartridge											
	•	•			all	M5x11	Torx screw	TX25	8	1,5	30696524**
			•		all	M4x8,5	Torx screw	15IP	5	0,7	30412229**
				•	all	M5x8	Torx screw	TX25	8	2,3	30499981
Adjusting wedge											
	•	•			32 - 40		Adjusting wedge			1,7	30696527
	•	•		•	50 - 400		Adjusting wedge			1,6	30696526
			•		all		Adjusting wedge			1,6	30557564
Threaded spindle											
		•	•		32 - 40***	M5x0,5L/REx11,5	Threaded spindle	SW 2,5		2,0	30696528
	•	•	•	•	From 50	M5x0,5LH/RHx17	Threaded spindle	SW 2,5		1,2	30696525
Locking screw											
				•	80 - 160	M4x6	Locking screw	SW 2	2	0,3	30367364
Balancing screws											
	•	•	•	•	80 - 160	M6x10	Threaded pin			1,4	10040022
	•	•	•	•	200 - 400	M10x10	Threaded pin			2,7	10012542
	•	•	•	•	****	M8x10	Threaded pin			2,2	10040023

* Face milling cutter diameter.
 ** Only suitable for single use.
 *** RBC to 50.
 **** Only suitable for custom milling cutters.







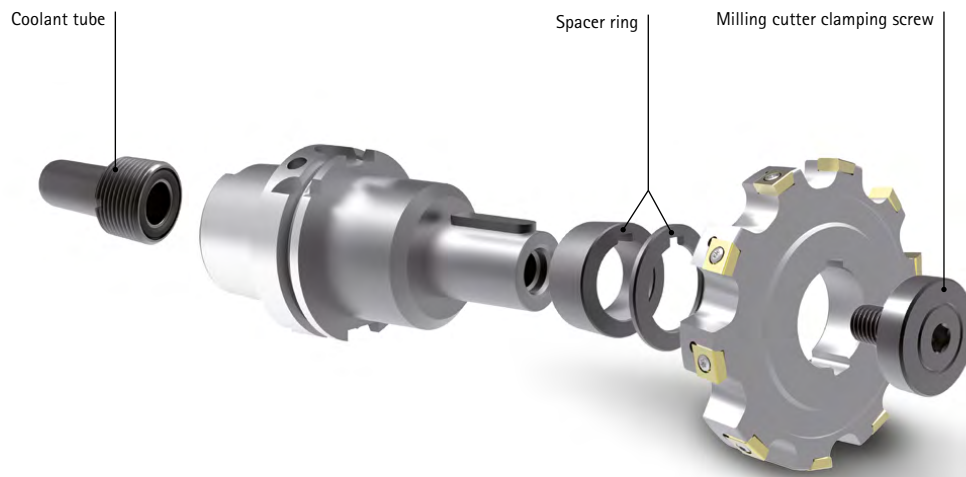

	EMC	EBC	RBC	FMC	d* [mm]	Dimension	Description	Wrench size / Torx size	Tightening torque [Nm]	Weight [g]	Order no.
Fastening screw with coolant delivery											
	•				50		Coolant screw	SW 8	20	33,6	30430829
	•				63		Coolant screw	SW 10	50	82,3	30326178
	•				80		Coolant screw	SW 12	80	176,2	30326179
	•				100		Coolant screw	SW 14	100	263	30326180
	•				125 - 140		Coolant screw	SW 14	200	595	30326181
		•	•		50		Coolant screw	SW 8	20	197	30543340
		•	•		63		Coolant screw	SW 10	50	69,4	30543341
		•	•		80		Coolant screw	SW 12	80	128,3	30543342
		•	•		100		Coolant screw	SW 14	100	203,5	30543344
				•	63		Coolant screw	SW 24	70	40	30772751-600
				•	80 - 160	M12x20	Coolant screw	SW 24	80	47	30381973-601
				•	80 - 160	ø 36 mm	Washer			21	30381973-600
Coolant cover											
	•				160 - 180		Coolant cover			200	30696538
	•				200		Coolant cover			500	30696539
	•				250		Coolant cover			700	30696540
	•				315		Coolant cover			1300	30696541
	•				400		Coolant cover			2300	30696542
Coolant cover including coolant sealing ring											
		•	•		160		Coolant cover			140,4	30569889
		•	•		200		Coolant cover			256,2	30569890
		•	•		250		Coolant cover			540,2	30569891
		•	•		315		Coolant cover			940	30569892
		•	•		400		Coolant cover			1550	30569893
Fastening screw for coolant cover											
	•	•	•		160 - 400	M6x18	Countersunk screw	SW 4		4,3	30670137
Accessories**											
Fastening screw for milling cutter arbors											
	•	•	•		160	M12x45	Cylinder head screw in acc. with ISO 4762	SW 10	70	84	10006594
	•	•	•		200 - 400	M16x50	Cylinder head screw in acc. with ISO 4762	SW 14	70	140	10007775

* Face milling cutter diameter.
 ** Not included in scope of delivery.

Accessories and spare parts for milling cutter with indexable inserts (1/2)

	Dimension	Comments	Wrench size / Torx size	Order no.
Threaded pin				
	M3X5-45H	Threaded pin ISO 4026	SW 1,5	10003421
	M3x8	Reducer of the coolant bore with helix and shell end face milling cutter	SW 1,5	30433620
Threaded spindle				
	M6x0.75	M6x0.75 LH/RHx23.4 for ONKU0705	15IP	31041869
Clamping wedge				
	M6X0.75 LH	for ONKU0705 (close spacing)		31071645
Clamping plate				
		Screw lock for RD__1604		31161929
Threaded bush				
	M6x11	for LTHU1505,1507	SW 4	30413235
Backing plate				
	9,26x15,7	Balancing plate for LTHU1505		30413233
Coolant tube				
		DIN 69895-KSR-63		30326006
		DIN 69895-KSR-80		30326007
		DIN 69895-KSR-100		30326008

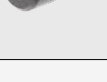

	d* [mm]	Dimension	Comments	Wrench size / Torx size	Tightening torque [Nm]	Order no.
Spacer ring DIN 2084-B						
	32	t=20	for TGMill-2-Disc/-4-Disc with WSP CT__			10020571
	32	t=3	for TGMill-2-Disc/-4-Disc with WSP CT__			10020564
	40	t=20	for TGMill-2-Disc/-4-Disc with WSP CT__			10004780
	40	t=6	for TGMill-2-Disc/-4-Disc with WSP CT__			10004418
Milling cutter clamping screw						
	27	M12x22	DIN 6367 without internal cooling	SW 10	137	10005164
	32	M16x26		SW 14	320	10004065
	40	M20x30		SW 17	622	10004066
	27	M12x22	DIN 6367 without internal cooling	SW 8	70	10006125
	32	M16x26		SW 10	95	10009686
	40	M20x30		SW 12	125	10006126
	22	M10x18	With internal cooling	SW 10	50	10053822
	27	M12x22		SW 12	70	10049206
	32	M16x26		SW 14	100	10073932
	40	M20x30	SW 14	125	10064487	
	16	M8x30	Cylinder head screw in acc. with ISO 4762 with internal cooling (according to MN692BL4)	SW 6	30	31006779
	22	M10x30		SW 8	60	31006800
	27	M12x35		SW 10	100	31008546
32	M16x40	SW 14		250	31008547	
	40	M20x45	SW 17	450	31009716	
	16	M8X30	Cylinder head screw in acc. with ISO 4762	SW 6	35	10003638
	22	M8X40		SW 6	35	10003640
	22	M10X25		SW 8	70	10003659
	22	M10x30		SW 8	70	10003660
	22	M10X50		SW 8	70	10003663
	27	M12X35		SW 10	120	10003677
	27	M12X50		SW 10	120	10003679
	27	M12X60		SW 10	120	10003680
	32	M16X35		SW 14	300	10003690
	32	M16X50		SW 14	300	10007775
	32	M16X60		SW 14	300	10006564
	32	M16X65		SW 14	300	10022995
	40	M20X60		SW 17	550	10015925
40	M20X45	SW 17		550	10111521	

* Face milling cutter diameter.

Accessories and spare parts for milling cutter with indexable inserts (2/2)

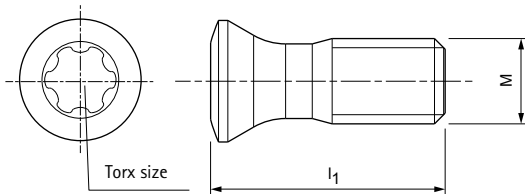

Clamping screw for radial indexable inserts

	Indexable insert	Size of indexable insert	Clamping screw					Screwdriver	
			Dimension	Description	Tightening torque [Nm]	Torx size	Order no.	Order no.	
	OF...	0704	M5x13	MN659 M5x13-TX20-IP	7,5	20IP	10105084	30414766	
	ON...	0705	M5x13	MN659 M5x13-TX20-IP	7,5	20IP	10105084	30414766	
	AO...	12T3	M3x6.5	MN659 M3x6.5-TX8-IP	1,8	8IP	10105074	30414760	
			M3x7.5	MN659 M3x7.5-TX8-IP	1,8	8IP	10105075	30414760	
	AN...	1205	M3x8.5	MN659 M3x8.5-TX8-IP	1,8	8IP	10105076	30414760	
	SD...	10T3	M3x7.5	MN659 M3x7.5-TX8-IP	1,8	8IP	10105075	30414760	
	SN...	1205	M4x11	MN659 M4x11-TX15-IP	4	15IP	10018468	30414764	
	LP...	0602	M1.8X4.09	M1.8X4.09-TX6-IP	0,9	6IP	31164571	30414758	
	LD...	1004	M2.5X5.9	M2.5X5.9-TX8-IP	1,5	8IP	31161842	30414760	
			M2.5X6.8	M2.5X6.8-TX8-IP	2	8IP	31161843	30414760	
			1804	M3.5X10	M3.5X10-TX15-IP	3,5	15IP	30870699	30414764
	SD...	0602	M2.2X5.2	M2.2X5.2-TX7-IP	1,2	7IP	31161853	30414759	
			1004	M3X8.3	M3X8.3-TX9-IP	2	9IP	31161852	30414761
			1405	M5X10.8	M5X10.8-TX20-IP	5	20IP	31161851	30414766
			1806	M6X15	M6X15-T25	6	T25	31161862	10019476
			RD...	0501	M1.8X3.7	M1.8X3.7-TX6-IP	0,6	6IP	31161858
	0702	M2.5X5.5			M2.5X5.5-TX7-IP	1,4	7IP	31161854	30414759
	1003	M3.5X7.2			M3.5X7.2-TX15-IP	3,5	15IP	31161859	30414764
	12T3	M3.5X8.6			M3.5X8.6-TX15-IP	3,5	15IP	31161860	30414764
		M3.5X7.2			M3.5X7.2-TX15-IP	5	15IP	31161928	30414764
1604	M4.5X10.5	M4.5X10.5-TX20-IP			5,5	20IP	31161861	30414766	
XDHT	1504	M4X7.8	M4X7.8-TX15-IP	4	15IP	31438975	30414764		
XPKT	1104	M3.5X8.1	M3.5X8.1-TX10-IP	2,8	10IP	30979520	30414763		

Clamping screw for tangential indexable inserts

	Indexable insert	Size of indexable insert	Clamping screw					Screwdriver
			Dimension	Description	Tightening torque [Nm]	Torx size	Order no.	Order no.
	LT...	1505, 1507	M4x17	MN659 M4x17-TX15-IP	4,0	15IP	30414702	30414764
	CT...	09T3	M3.5x9.4	MN659 M3.5x9.4-TX10-IP	2,8	10IP	10007315	30414763
		0905	M3.5x11	MN659 M3.5x11-TX10-IP	2,8	10IP	10105079	30414763

High-temperature screw paste

	Description	Order no.
	Ceramic paste/re-sealable PE tube 30 g	30861389

Allocating milling cutter clamping screws for milling cutters with indexable inserts

Series	Diameter of milling cutter	Diameter of milling cutter arbor	Milling cutter clamping screw				
			Without internal cooling*	Without internal cooling	With internal cooling*	Without internal cooling*	With internal cooling
							
NeoMill®-8-Face, OFMT07 	63	22	-	-	-	10003660	31006800
	80	27	-	-	-	10003677	31008546
	100	32	-	-	-	10003690	31008547
	125	40	-	-	-	10111521	31009716
	160	40	10004066	-	-	10006594 (x4)	-
	200	60	-	-	-	10022995 (x4)	-
NeoMill®-16-Face, ONKU07 	63	22	-	-	-	10003660	31006800
	80	27	-	-	-	10003677	31008546
	100	32	-	-	-	10003690	31008547
	125	40	-	-	-	10111521	31009716
	160	40	10004066	-	-	10006594 (x4)	-
	200	60	-	-	-	10022995 (x4)	-
TGMill-4-Face45, LTHU15 	80	27	10005164	10006125	10049206	-	-
	100	32	10004065	10009686	10073932	-	-
	125	40	10004066	10006126	10064487	-	-
	160	40	-	-	-	10003680 (x4)	-
	200	60	-	-	-	10006564 (x4)	-
NeoMill®-2-Corner, AOKT12 NeoMill®-4S-Corner, SDKT10 NeoMill®-8-Corner, SNMU12 	40	16	-	-	-	10003638	31006779
	50	22	-	-	-	10003660	31006800
	63	22	-	-	-	10003660	31006800
	80	27	-	-	-	10003677	31008546
	100	32	-	-	-	10003690	31008547
	125	40	-	-	-	10111521	31009716
	160	40	10004066	-	-	10006594 (x4)	-
200	60	-	-	-	10022995 (x4)	-	
NeoMill®-4-Corner, ANMU12 	40	16	-	-	-	10003638	31006779
	50	22	-	-	-	10003660	31006800
	63	22	-	-	-	10003660	31006800
	80	32	-	-	-	10003677	31008546
	100	40	-	-	-	10003690	31008547
TGMill-2-Corner, CT_D09 TGMill-4-Corner, CT_Q09 	63	22	-	-	10053822*	-	-
	80	27	10005164	10006125	10049206	-	-
	100	32	10004065	10009686	10073932	-	-
	125	40	10004066	10006126	10064487	-	-
	160	40	-	-	-	10003680 (x4)	-
	200	60	-	-	-	10006564 (x4)	-
NeoMill®-2-HiFeed90, LP_06 	32	16	-	-	-	10003638	-
	40	16	-	-	-	10003638	-
	50	22	-	-	-	10003659	-

Series	Diameter of milling cutter	Diameter of milling cutter arbor	Milling cutter clamping screw				
			Without internal cooling**	Without internal cooling	With internal cooling*	Without internal cooling*	With internal cooling
							
NeoMill®-2-HiFeed90, LD_10 	40	16	-	-	-	10003637	-
	50 - 63	22	-	-	-	10003659	-
	80	27	-	-	-	10003677	-
NeoMill®-2-HiFeed90, LD_18 	40	16	-	-	-	10003638	-
	50 - 66	22	-	-	-	10003659	-
	80	27	-	-	-	10003677	-
	100	32	-	-	-	10006565	-
	125	40	-	-	-	10009106	-
	160	40	10004066	-	-	10006594 (x4)	-
NeoMill®-4-HiFeed90, SD_10 	40	16	-	-	-	31166231	-
	50 - 66	22	-	-	-	10003659	-
	80	27	-	-	-	10003677	-
NeoMill®-4-HiFeed90, SD_14 	50 - 52	22	-	-	-	31166232	-
	63 - 66	22	-	-	-	10003659	-
	80	27	-	-	-	10003677	-
	100	32	-	-	-	10003690	-
	125	40	-	-	-	10081881	-
NeoMill®-4-HiFeed90, SD_18 	80	27	-	-	-	10003677	-
	100	32	-	-	-	10003690	-
	125	40	-	-	-	10081881	-
	160	40	10004066	-	-	10006594 (x4)	-
	200	60	-	-	-	10006594 (x4)	-
NeoMill®-ISO-360 	40 - 42	16	-	-	-	10003639	-
	48 - 52	22	-	-	-	10003660	-
	63 - 80	27	-	-	-	10003677	-
	100	32	-	-	-	10003690	-
	125	40	-	-	-	10111521	-
	160	40	10004066	-	-	10006594 (x4)	-
NeoMill®-4-Shell, ANMU12 	40	16	-	-	-	10003638	-
	50	22	-	-	-	10003660	-
	63	27	-	-	-	10003677	-
TGMill-2-Disc, CT_D09 TGMill-4-Disc, CT_Q09 	100 - 125	32	10004065	10009686	-	-	-
	160 - 200	40	10004066	10006126	-	-	-

Dimensions in mm.

* Included in scope of delivery for the tool body.

** Optional for clamping via central control.

General Accessories – Screwdriver

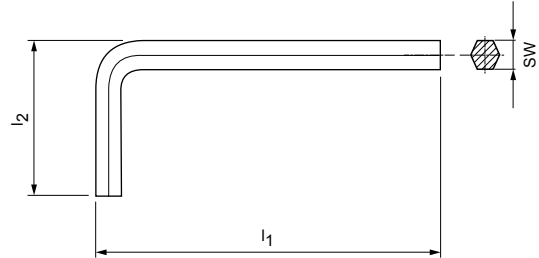
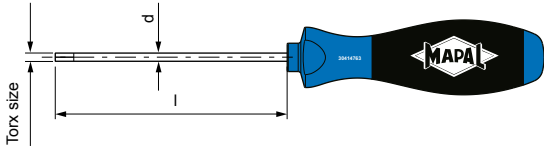

Screwdriver

Dimensions			Description	Order no.	
l [mm]	d [mm]	Torx size			
60	3,5	6IP	TORX PLUS®	30414758	
60	3,5	7IP		30414759	
60	3,5	8IP		30414760	
60	4	9IP		30414761	
80	4	10IP		30414763	
80	4	15IP		30414764	
100	4	20IP		30414766	
100	4,5	25IP		30414767	
60	3,5	TX8		TORX®	10019467
80	4	TX15			10019469

Allen wrench

Dimensions			Description	Order no.
l ₁ [mm]	l ₂ [mm]	SW		
46,5	15,5	SW 1,5	ISO2936-X	10004870
52	18	SW 2		10004356

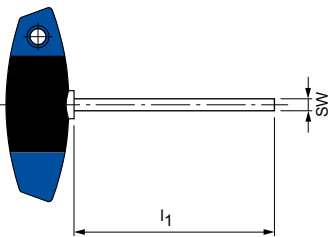

Hexagonal T-key

Wrench size SW	Short design			Long design	
	l ₁ [mm]	Specification	Order no.	l ₁ [mm]	Order no.
SW 2,5	100	-	10006233	200	10032722
SW 3	100	MN5221-31	10006234	200	10025313
SW 4	100	MN5221-32	10006235	200	10018010
SW 5	100	MN5221-33	10006236	200	10013350
SW 6	100	MN5221-34	10006237	-	-
SW 8	100	MN5221-35	10006238	-	-
SW 10	100	-	30353270	-	-
SW 12	-	-	-	200	30353272

General Accessories – Torque Wrench Set, Screwdriver Set



TorqueVario®-STplus T-key torque wrench 11 pcs. set

Model: 5–14 Nm

Scope of delivery	Features	Order no.
<ul style="list-style-type: none"> • 1 T-handle torque wrench • 1 Torque-Tplus Setter • 1 Universal bit holder 1/4" • 3 TORX® standard bits T25x25 / T30x25 / T40x25 • 3 hex standard bits 4.0x25 / 5.0x25 / 6.0x25 • 2 adapter bits for the sockets <ul style="list-style-type: none"> 1 Torque-Tplus adapter bit 1/4" 1 Torque-Tplus adapter bit 3/8" • Stable metal box 	<ul style="list-style-type: none"> • Accuracy $\pm 6\%$, can be traced to national standards • Numeric torque value indication on window scale • Torque continuously adjustable • Comfortable T-handle with soft zones • Click signal on reaching the set torque 	30415173



TorqueVario®-S torque screwdriver 13 pcs. set

Model: 1.0–5.0 Nm

Scope of delivery	Features	Order no.
<ul style="list-style-type: none"> • 1 TorqueVario-S torque screwdriver • 1 torque setter • 1 Universal bit holder 1/4" • 5 TORX® standard bits T7x25 / T8x25 / T9x25 / T10x25 / T15x25 • 5 TORX PLUS® standard bits 7IPx25 / 8IPx25 / 9IPx25 / 10IPx25 / 15IPx25 • Stable metal box 	<ul style="list-style-type: none"> • Accuracy $\pm 6\%$, can be traced to national standards • Numeric torque value indication on window scale • Torque continuously adjustable • Ergonomic multiple component handle • Click signal on reaching the set torque 	30415174

$$h_m = f_z \cdot \sqrt{\frac{a_e}{D}} \text{ [mm]}$$

 a_p $\cos \varphi_s =$ d 

TECHNICAL APPENDIX

Notes on application and handling

$$1 - \frac{2 \cdot a_e}{D}$$



59.5
Antriebsauslastung - Anzeige
X1 Y1 Z1 C1 B1 SPM U1
Kanal 1
01/07 Service Info
DATE: 03.04.11 TIME: 16:28:25 (24.7)
MEL 4 Betriebsart aktiv
NC/UKS/4_1471_SPM_STANDARDPROG/SPM_2_2
782012
RESET UKS
Position [mm]
X 226.533
Y 33.867
Z 46.362
C 0.000
B 0.000
G55
TFS
T SPM_STANDARD D1
F SPM_STANDARD R0.000 L137.750
S1 Master 0 mm/min 0.0%
100%
Zoom Istwert
T.S.M NPV setzen Nullp. Werkst. Werkz. messen Position Planfräsen Schwenken



TECHNICAL APPENDIX

General technical information

Terminology and formulae	394
Technical information	396

Application notes

Facing and shoulder milling	398
Helix milling	400
Trochoidal milling	402

Handling notes

CPMill replaceable milling cutters	404
PCD face milling cutter – Power system	406
PCD face milling cutter – Eco system	408
Face milling cutter with radial indexable inserts	410
Milling cutter clamping screw	412

MAPAL Maintenance Services

Reconditioning for face milling heads	414
---------------------------------------------	-----

Terminology and Formulae

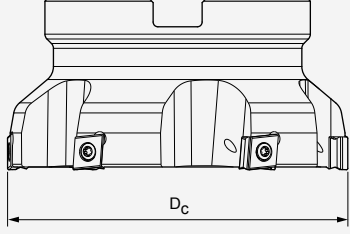
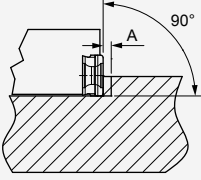
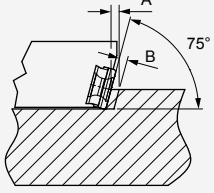
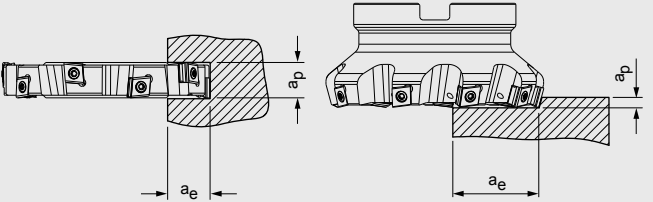
Diameter of milling cutter	D_c [mm]	Setting angle	K
		 	
Average roughness	R_a [μ m]	Cutting depth	a_p [mm]
Average roughness depth	R_z [μ m]	Cutting width	a_e [mm]
Number of inserts	z		
Spindle speed	n [U/min]		

Formulae

Feed per turn	$f_u = \left[\frac{\text{mm}}{U} \right]$	$f_u = z \cdot f_z$
Feed per tooth	$f_z = \left[\frac{\text{mm}}{\text{Tooth}} \right]$	$f_z = \frac{vf}{n \cdot z}$

f_z during face milling:

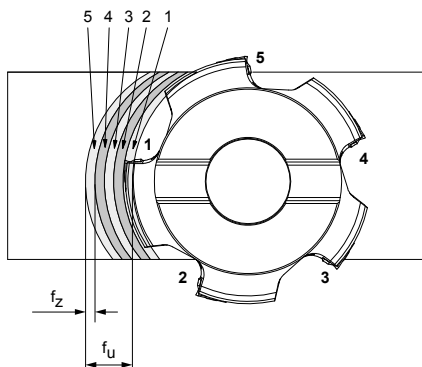

Spindle speed	$n = [\text{min}^{-1}]$	$n = \frac{v_c \cdot 1.000}{\pi \cdot D}$
Average chip thickness	$h_m = [\text{mm}]$	$h_m = \sin \kappa \cdot f_z \cdot \sqrt{\frac{a_e}{D}}$
Cutting speed	$v_c = \left[\frac{\text{m}}{\text{min}} \right]$	$v_c = \frac{\pi \cdot D_c \cdot n}{1.000}$
Feed rate	$v_f = \left[\frac{\text{mm}}{\text{min}} \right]$	$v_f = f_z \cdot z \cdot n$
Material removal rate	$Q = \left[\frac{\text{cm}^3}{\text{min}} \right]$	$Q = \frac{a_e \cdot a_p \cdot v_f}{1.000}$

Disc, groove, shoulder milling

Feed value compensation

Machining steps with low radial cutting depth such as disc milling, groove milling or milling a shoulder require correction of the feed at the insert as it enters the work-piece.

The calculated and actual feed can vary depending on the cutting depth and the diameter of milling cutter used.

If a shoulder with a cutting depth of only 0.5 mm is machined using a milling cutter diameter of 40 mm, the feed must be multiplied by a factor of 5 to arrive at the actual feed or $f_z = 0.1$ mm (see example below).

A major advantage of the application of this formula is the increase in productivity with the effective use of the milling cutter.

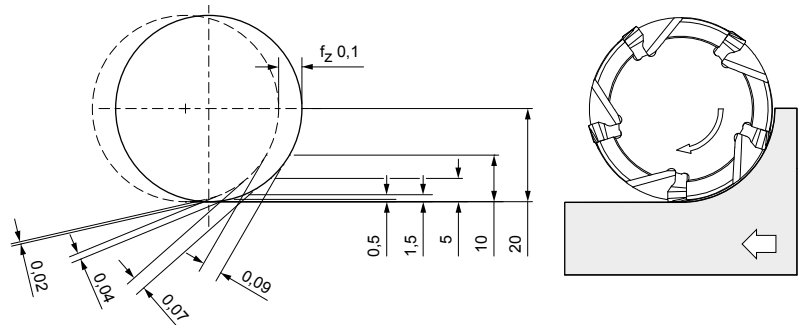

Example:

Tool: Diameter of milling cutter 40 mm
 z: 5
 f_z : 0.1 mm
 f: 0.5 mm/rev

Radial cutting depth a_p [mm]	Feed per tooth f_z [mm]	Maximum chip thickness h_{max} [mm]	Required v_f to obtain $f_z = 0.1$ mm	Increase factor
20	0,1	0,1	1.000	1,00
10	0,1	0,09	1.111	1,11
5	0,1	0,07	1.429	1,43
1,5	0,1	0,04	2.500	2,50
0,5	0,1	0,02	5.000	5,00

Note: Based on the above example, the feed per tooth can be increased with a low a_p/D ratio or a setting angle $< 90^\circ$.

Technical Information Milling

Selection of the setting angle

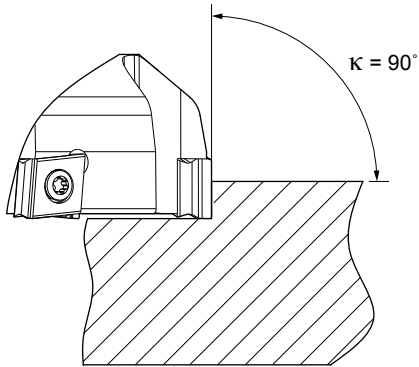

Advantages:

- For thin-walled workpieces
- For difficult clamping situations of the workpiece
- For 90° shoulder machining

Disadvantages:

- Highest radial forces
- High load on impact when penetrating the material
- Increased probability of the formation of burrs as the cutting edge exits

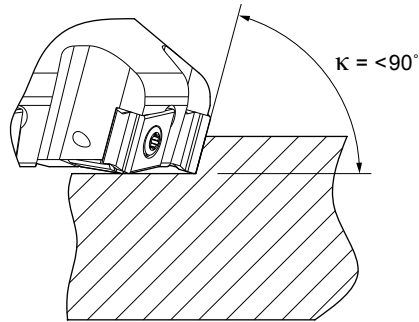

Advantages:

- For general milling applications
- Good ratio of cutting edge size to maximum cutting depth
- Reduced impact load on the insert on penetrating the material

Disadvantages:

- Higher radial forces can cause problems in case of low-power machines or poorly clamped workpieces

Position of the milling cutter diameter and the milling cutter position

The milling cutter diameter is to be selected as a function of the size of the workpiece or the width of the workpiece as well as the power of the machine. During face milling, e.g., the milling cutter diameter should be 20-50% larger than the cutting width on the workpiece.

The position of the milling cutter and the insert contact on entering and exiting the workpiece affect the machining result.

Optimal milling cutter diameter

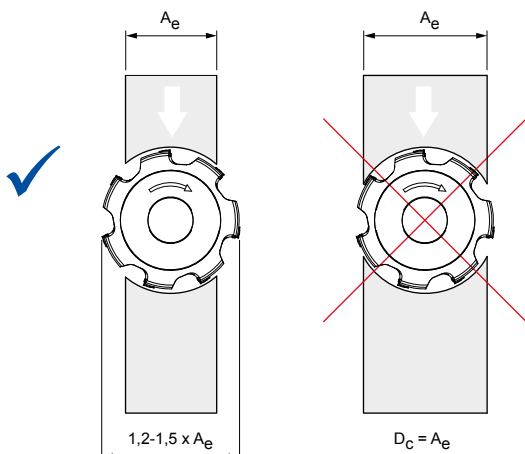

Optimal position

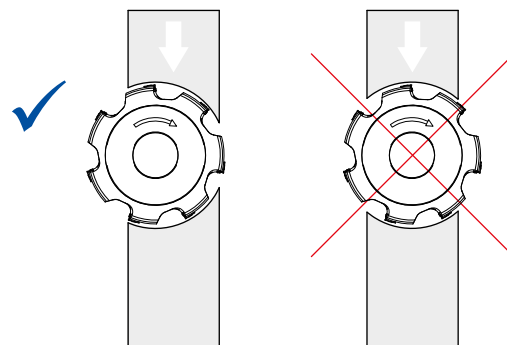

Differentiation based on running direction

Counter feed milling

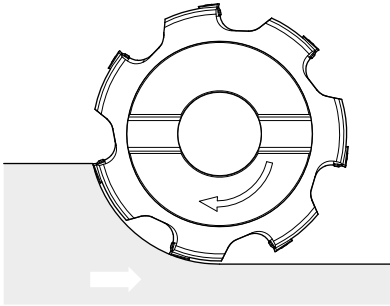

When the insert enters the chip-removing cut, the insert has the unfavourable chipping thickness zero in terms of machining technology and exits the workpiece material with the maximum chipping thickness h_{max} . Friction is produced during counter feed milling. This friction results in chip welding and the transfer of heat to the indexable insert and in the workpiece.

In the case of counter feed milling, the resulting forces are against the direction of feed. It is likely that material strain hardening will occur.

Synchronous milling (preferred)

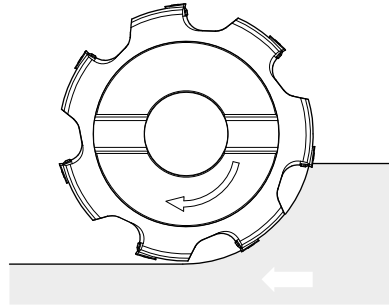

Synchronous milling is generally recommended. When entering the material, the insert has a specific feed per tooth and with a maximum chipping thickness h_{max} generates a chip that becomes thinner on exiting the chip-removing cut. This aspect reduces the heat by transferring it to the chip. The material strain hardening is minimised.

Production of surfaces

Axially produced surfaces:

During face milling, the surface quality is primarily generated by the cutting edge geometry and the feed.

Improvement of surface quality:

Compared to a conventional cutting edge geometry, with a wide finishing indexable insert a R_a and R_z value several times better is achieved with the same feed.

Standard geometry

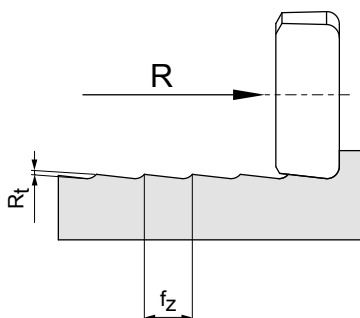

Wide finishing geometry

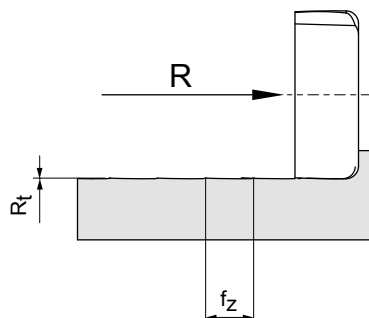

Face and Shoulder Milling

Two-axis angled entry – linear (flute)

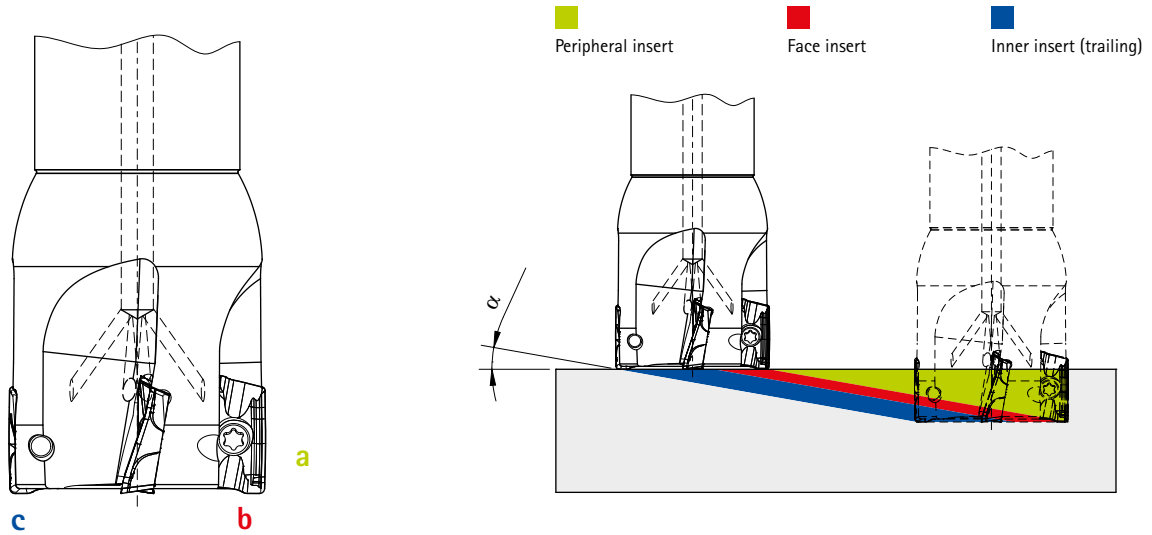

Ramp angle α :

The maximum plunge angle α is dependent on the tool.

In case of two-axis angled entry, various machining processes take place at the same time:

- a) Machining at the entire periphery of the tool (peripheral machining) with leading insert.
- b) Machining at the face of the milling cutter with leading insert.
- c) Machining at the face of the milling cutter with trailing insert.

Application notes

For end milling cutter NeoMill-2-Corner

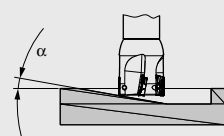
Plunge milling	Diameter of milling cutter [mm]	Indexable insert that can be used	Maximum ramp angle α [°]
	\varnothing 20	AOKT12T3	6,0
	\varnothing 25		4,2
	\varnothing 32		3,0
	\varnothing 36		2,6
	\varnothing 40		2,2

For milling cutter NeoMill-2-Corner

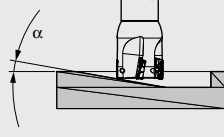
Plunge milling	Diameter of milling cutter [mm]	Indexable insert that can be used	Maximum ramp angle α [°]
	\varnothing 40	AOKT12T3	2,2
	\varnothing 50		1,7
	\varnothing 55		1,5
	\varnothing 63		1,3
	\varnothing 80		1,0
	dia. 100 and more		not recommended

Feed value compensation

Machining steps with low radial cutting depth, such as milling a shoulder, require correction of the feed at the cutting edge as it enters the work-piece.

The recommended feed per tooth f_z varies depending on milling cutter diameter and operational time, that is the radial contact ratio of the milling cutter a_e/D . If this is less than 50 percent, the maximum chip thickness reduces relative to the feed f_z . The feed can be increased with the aid of the correction factor in the following diagram, depending on the a_e/D ratio.

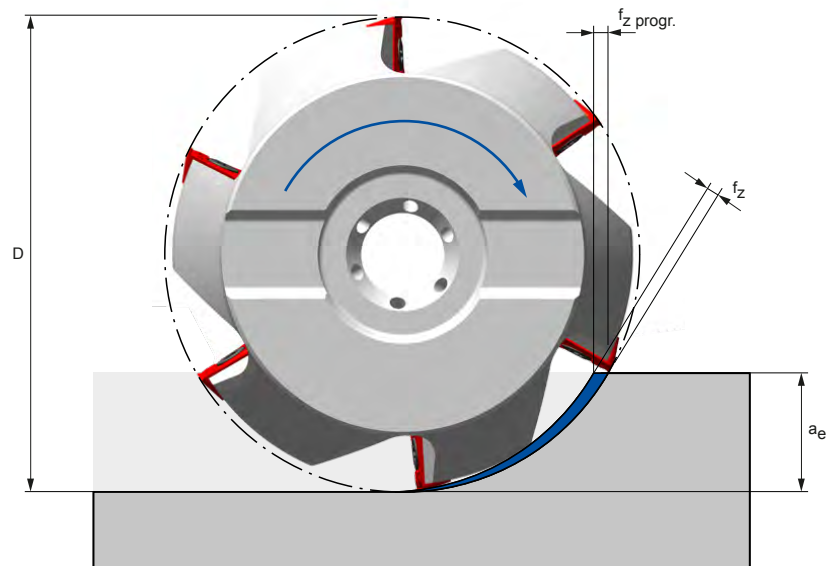

Feed value compensation

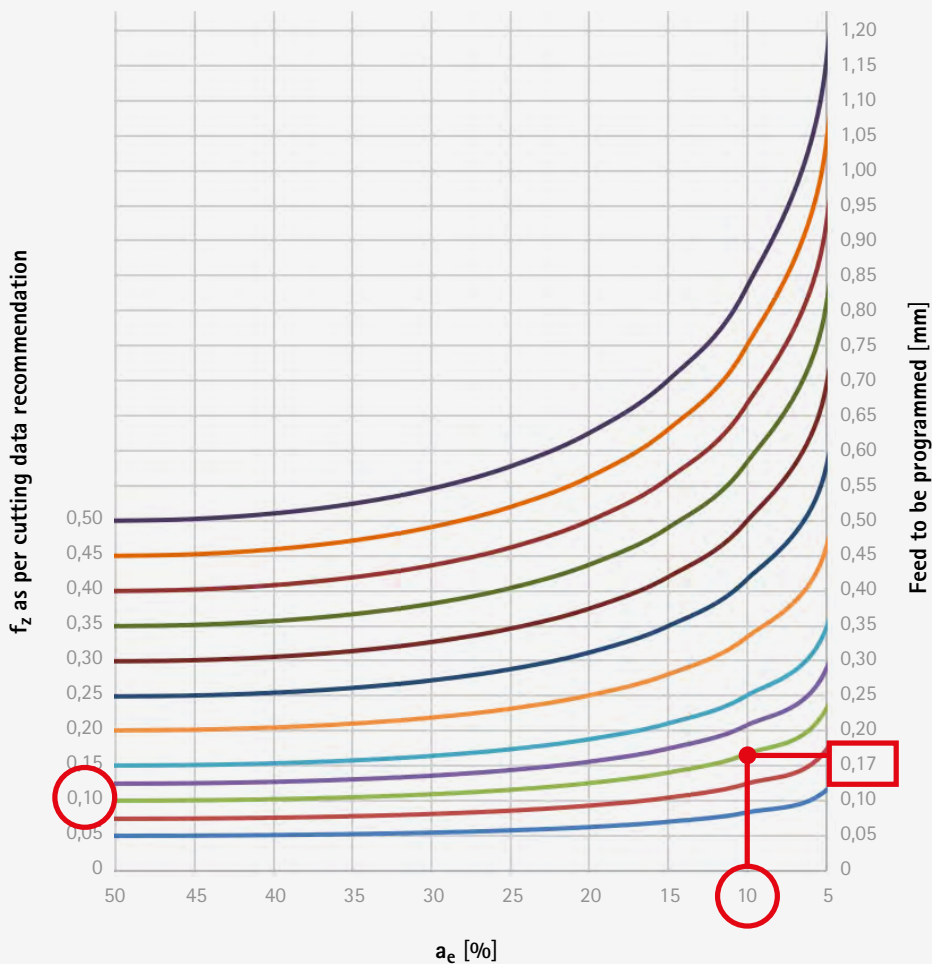

Example:

$D = 20$ mm
 $a_e = 2$ mm
 $f_z = 0.1$ mm
 $a_e/D = 10\%$
 $f_{z \text{ progr.}} = 0.17$ mm

Helix milling

Helical angled entry

The helical angled entry is an alternative to boring. This involves a circular movement with simultaneous axial feed.

Pitch (P):

The pitch (P) corresponds to the axial infeed per revolution. This depends on the workpiece, tool length, workpiece material and machine.

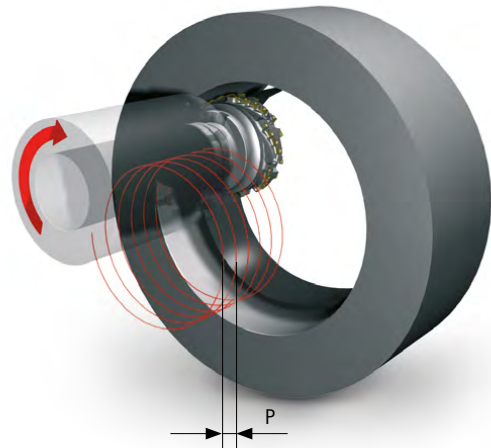

Application note	Tool ϕ [mm]	Max. possible plunge angle α [°]
	80	4,3
	100	3,4
	125	2,8
	140	2,4
	160	2,1

Selection of the milling cutter diameter as a function of the size of the bore

In the case of centre-cutting milling cutters it is important to select the correct ratio of diameter of milling cutter and bore diameter. The indexable insert must cut along the centre axis.

If the milling cutter diameter is too small, there is a core in the centre.

If the milling cutter diameter is too large, the centre is not machined. As a result a protrusion is left. This protrusion presses the milling cutter axially. This leads to a collision between the workpiece and tool.

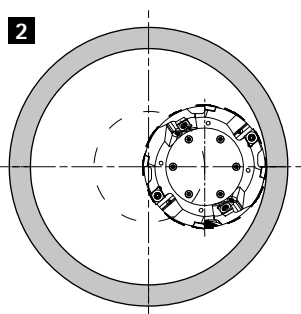
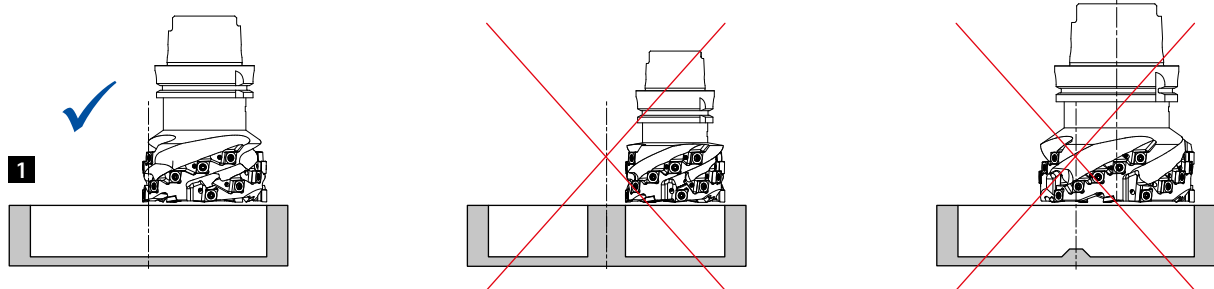

1 Drilling into the solid (flat bottom of the bore)

Diameter of milling cutter [mm]	80	100	125	140	160
Bore diameter [mm]	142-160	182-200	232-250	262-280	302-320

Note:

In the case of a bore diameter between the ranges stated, for example 170 mm, the smaller milling cutter with a diameter of 80 mm is selected. Two machining steps are then necessary to machine the bore.

2 Enlarging a bore (no face machining)

Milling cutter diameter = < 0.5 x bore diameter

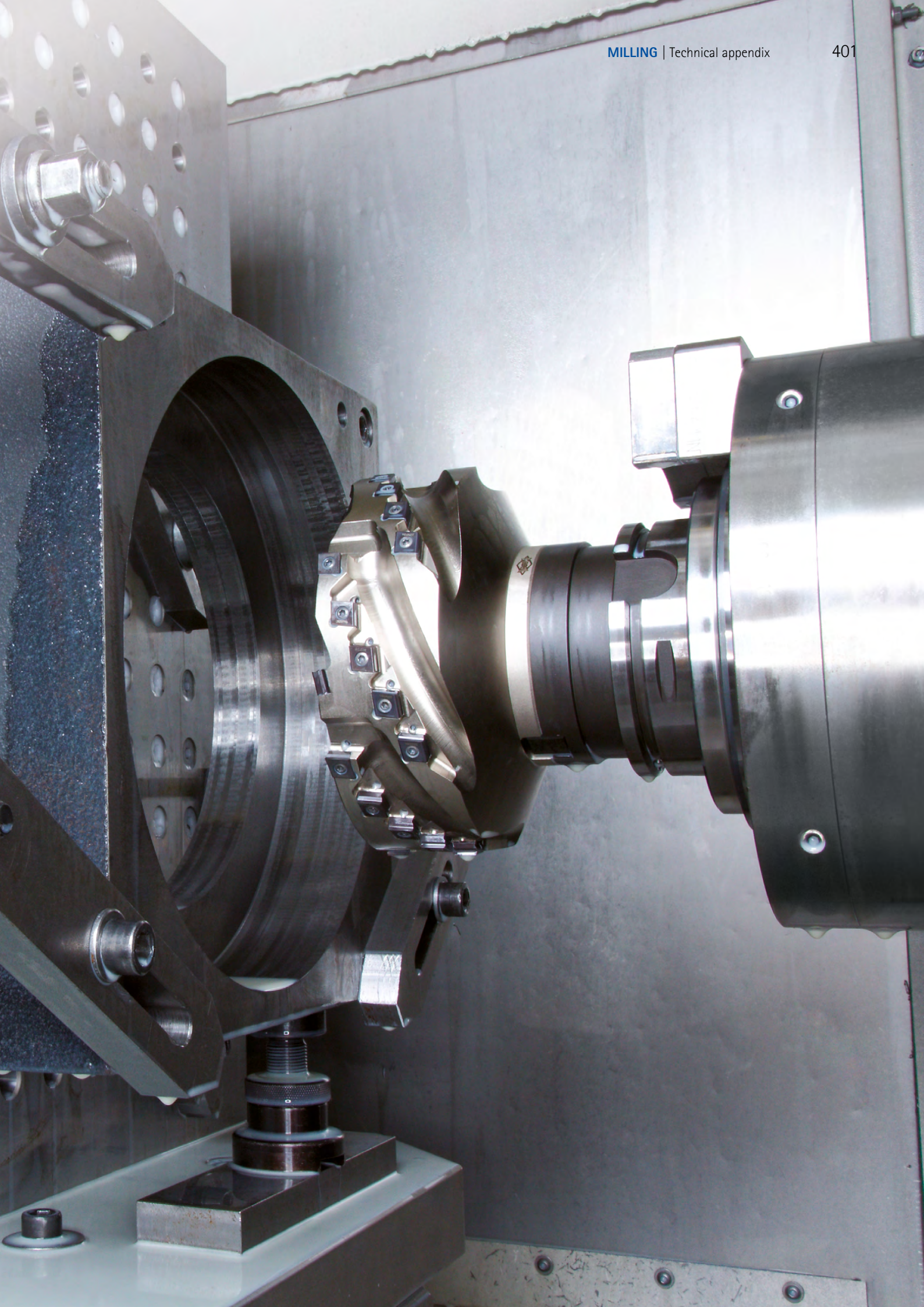

Trochoidal milling – principles

Definition

Trochoidal milling is a milling strategy with the aim of reducing process forces and simultaneously increasing material removal rates. By superimposing a circular movement of the tool on the feed movement, the contact conditions can be positively influenced. This results in cyclic material removal with variable contact conditions that can be adjusted to the tool application, as well as variable cutting widths along the circular path of the tool.



Example of full slot milling

Conventional milling

For roughing in a full cut, the contact conditions of the milling cutter are fixed at a wrapping angle of 180°.

In addition to the generation of long chips due to the long tooth contact, this leads to a comparatively high thermal load on the tool. The resulting large cutting cross section in turn results in high cutting forces, which limits process-stable infeed depths, feed rates and cutting speeds.

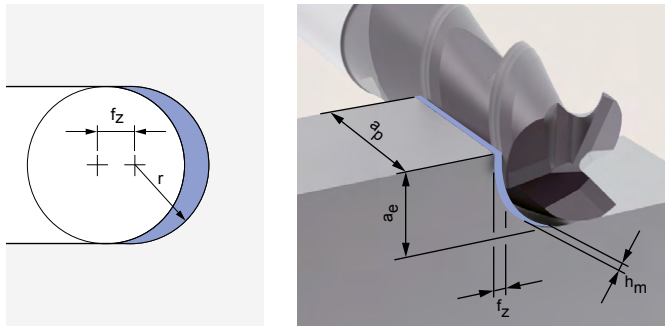

- a_p : small (cutting depth $\sim 1 \times D$)
- a_e : large ($1 \times D$)
- f_z : small
- v_c : low

Trochoidal milling

The specific kinematics of trochoidal milling makes it possible to positively influence the contact conditions as a circular movement of the tool is superimposed on the feed movement. The contact angle is correspondingly low.

The result of this technological approach is that a reduced cutting width and cutting length lead to significantly reduced process forces. This in turn makes it possible to achieve greater cutting depths.

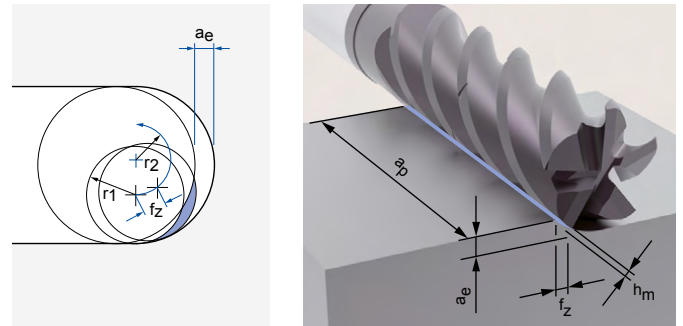

- a_p : large (full utilisation of the cutting edge length possible)
- a_e : small
- f_z : large
- v_c : high

Trochoidal milling – in detail

Trochoidal milling – circular path

For the case of a circular path with a constant radius, the wrapping angles on the contact tool cutting edge vary depending on the absolute radial material removal rate within one revolution.

- Contact conditions are constantly changing
- Optimal working range of the milling cutter
- Limited to a small area
- Low material removal rate
- Tends to vibrate more
- Increased tool wear

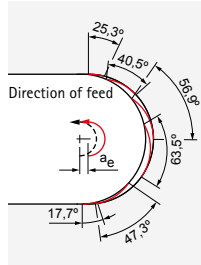

Wrapping as a function of the path position
- Circular path

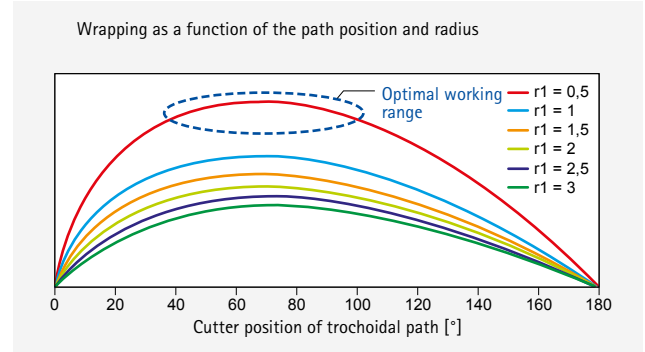

Trochoidal milling – optimised path curve

Through an adapted path movement of the tool, the contact ratios of the milling cutter can be kept constant at every point of the path over almost the entire machining operation. This means that the milling process can always be operated at its optimum. Within a path, the feed rate is adjusted so that the average chip thickness remains constant.

- Constant contact condition
- Constant strength level
- Less tool wear
- Maximum material removal rate

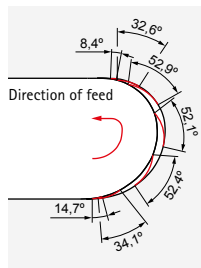

Wrapping as a function of the path position
- Optimised path curve

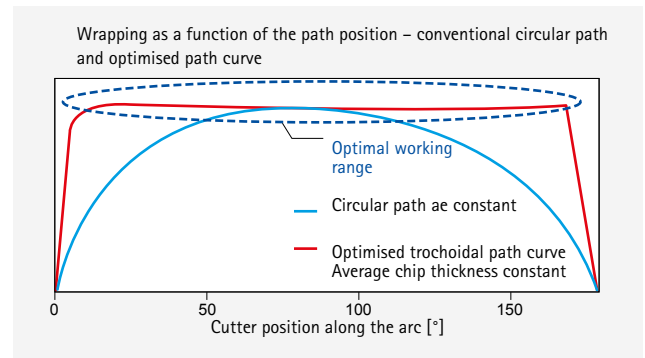

Feed movement – optimised air cut

For holistic process optimisation, the traversing motion in the air cut must be considered in addition to the tool path during engagement. The aim is to realise the fastest possible movement to the next entry point after the milling cutter has exited the material. Since the design of a circular path is not advantageous at this point, the most direct approach path possible is selected depending on the dynamics of the machine.

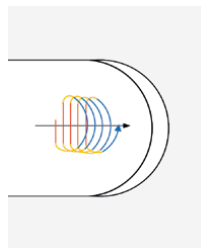

■ Feed
■ Ramp
■ Rapid traverse

NOTE

- In addition to a modern CAM system or a modern machine control system, trochoidal milling also requires a machining centre that is as dynamic as possible.
- Full performance is achieved by using OptiMill cutters from the Trochoid series.

Average chip thickness h_m and contact angle φ

Contact angle	$\varphi = [^\circ]$	$\cos\varphi = 1 - \frac{2 \cdot a_e}{D}$	Depends on the contact ratio a_e/D and is limited depending on the workpiece material.
Average chip thickness	$h_m = [mm]$	$h_m = f_z \cdot \sqrt{\frac{a_e}{D}}$	Is kept almost constant during trochoidal milling by dynamic feed rates. The average chip thickness is measured at $\varphi/2$.
Feed per tooth	$f_z = \frac{[mm]}{\text{Tooth}}$		Restricted variable, is adjusted during machining by CAM system.
Cutting width	$a_e = [mm]$		Constantly recalculated by the CAM software and limits the contact angle φ .
Tool diameter	$D = [mm]$		

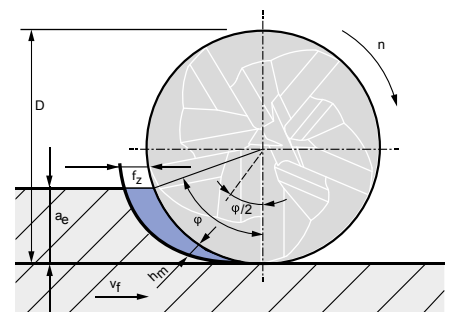

Handling notes for CPMill replaceable milling heads

The universally applicable replaceable milling heads from the CPMill series are characterised by a long tool life with consistently high machining quality. The CFS connection ensures simple and fast changing of the milling heads with high accuracy of repetition. At the same time, perfect retention with maximum stability and rigidity is achieved.

The replaceable milling head is tightened to the stipulated tightening torque and produces a joint with force and form fit. The key features of this system are high radial run-out accuracy in conjunction with very good rigidity.

Assembly of CPMill replaceable milling heads

Note:

To minimise the risk of injuries, it is recommended to wear gloves.

Comment:

For trained personnel only



1. Clean the taper, thread and face surface on the replaceable milling head using compressed air and a cloth.



2. Clean the taper, thread and face surface on the replaceable head holder using compressed air and a cloth.



3. Hand tighten the replaceable milling head clockwise into the replaceable head holder. Then clamp the replaceable head holder with the tool in the machine holder.



4. Place the torque wrench on the replaceable milling head so it is as horizontal as possible; do not tilt the faces on the wrench.



5. Note: Place your free hand on the replaceable milling head to be able to make delicate adjustments. This allows the tightening torque to be set more precisely.

Tighten the replaceable milling head using the torque wrench and the corresponding open-end spanner at the specified tightening torque (see table "Tightening torque of replaceable milling head").



Result:

The gap between the replaceable milling head and replaceable head holder is closed, producing a joint that is both force and form fit. The CPMill replaceable milling head is now ready for operation.

Tightening torques for replaceable milling heads

Connection size CFS	Tightening torque [Nm]
6	5
8	12,5
10	15
12	20
16	25
20	30



Handling notes for PCD face milling cutters – Power system

Applicable to milling cutters with Power and PowerBlue milling cartridges. The milling cartridges for the milling cutters Power are additionally secured using a locking screw. Pay attention to the optional steps here.

Changing and setting PCD milling cartridges

Requirements:

The hollow taper (HSK) face connection is checked for good condition and the milling cutter clamping screw / fastening screw with coolant delivery is tightened (for tightening torque, see page 409). The milling cutter is clamped on the setting fixture.

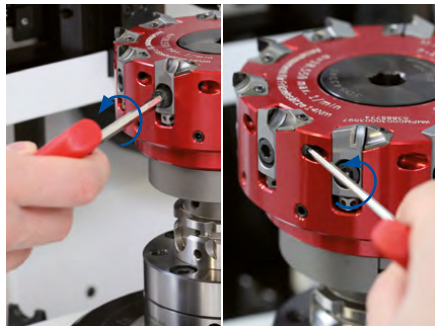

1. Undo and remove the milling cartridge clamping screw.

Optional:

Turn the locking screw a few turns in the anticlockwise direction.

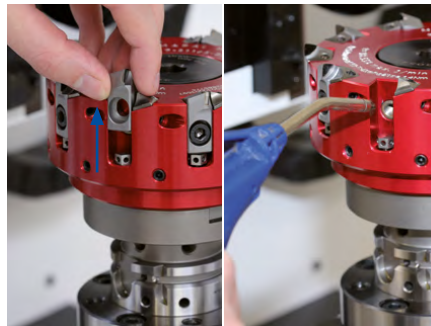

2. Remove the milling cartridge upward out of the seat for the milling cartridge. Then clean the seat for the milling cartridge using compressed air so the seat is free of residue.



3. **Optional:**

If the locking screw is not yet screwed in, check whether the flat side of the locking screw (2) is pointing in the direction of the milling cartridge seat. If a spherical shape can be seen (1), use your finger or a magnet to turn this to the flat position.

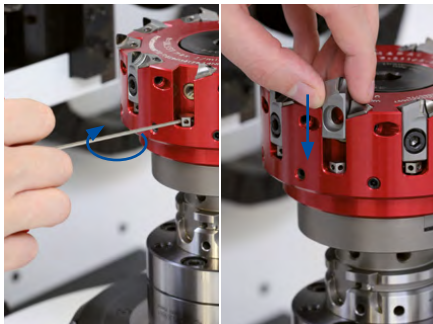

4.1 If the adjusting screw is not yet fitted, fit it and screw in to the stop using a hex-wrench. Then turn back the adjusting screw two turns in the anticlockwise direction. Then fit the new milling cartridge in the seat from above.

4.2 If the adjusting screw is already fitted, screw in the adjusting screw one half of a turn in the clockwise direction. Then fit the new milling cartridge in the seat from above.

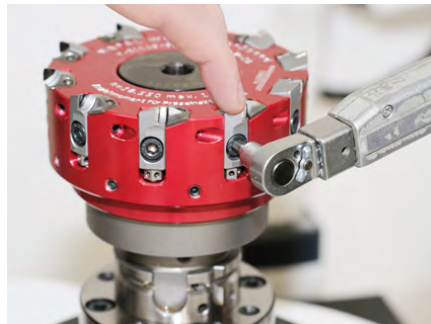

5. Fit the milling cartridge clamping screw and screw in lightly using a hex-wrench. Then carefully press down the milling cartridge with one finger and at the same time tighten the clamping screw to 4 Nm using a torque wrench.



6. **Optional:**

Screw in the locking screw clockwise to the stop using a hex-wrench and then screw back half a turn.

Comment:

- Only for trained personnel
- Clean the cutting edges on the milling cartridges using a cleaning compound to prevent measurement inaccuracies
- Clamping screws are only to be used once
- The fastening screw with coolant delivery is to be used with screw locking

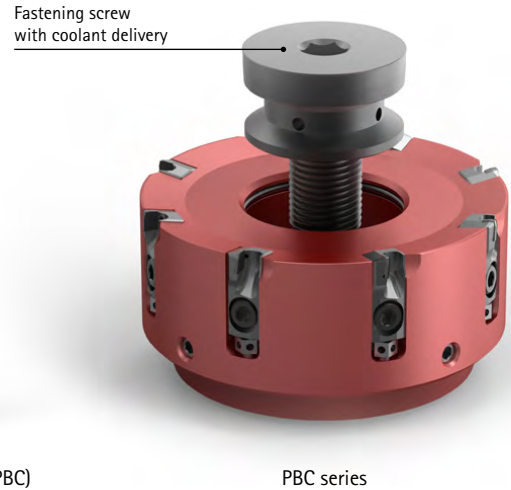
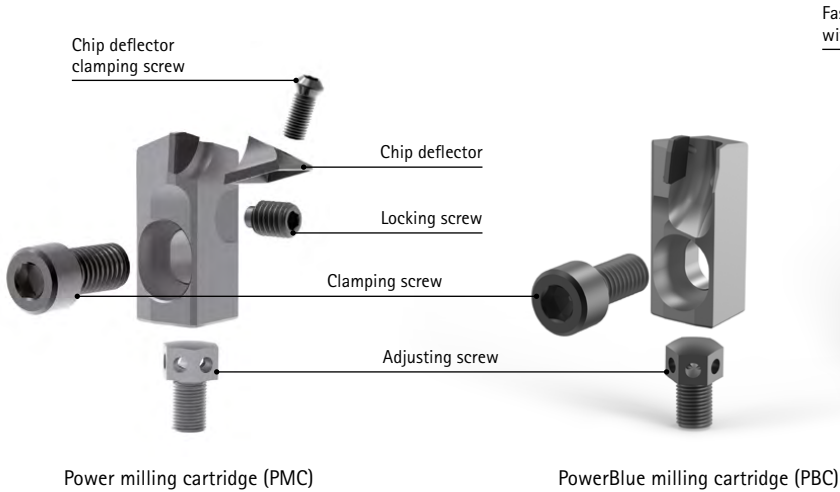

7. Setting using setting fixture (optical)

Acquire the cutting edge using the optical measuring device and using a hex-wrench turn the adjusting screw anticlockwise until the setting dimension (EM) = -0.015 mm is reached. For purely optical setting, repeat this process for the remaining milling cartridges (then continue with step 9).

Note:

To ensure the correct preload, after reaching the setting dimension undo the adjusting screw again and then adjust to the target value (setting dimension -0.015 mm).



8. Setting using a dial gauge (measuring plate)

Note:

The measuring sensor should have a low measuring force, max. 0.3 N, with a flat probe made of aluminium, magnesium or carbide.

Position the measuring sensor against the milling cartridge at the highest point and set the dial gauge to zero. Turn the milling cartridge upward with the aid of the adjusting screw until the setting dimension = -0.015 mm is reached. Repeat this action for all milling cartridges.

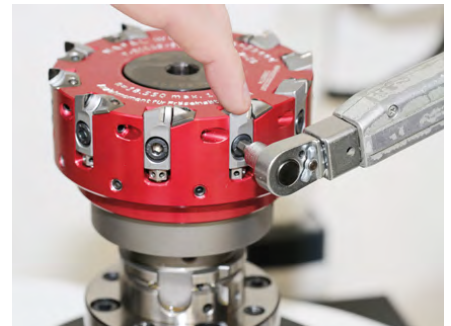

9. Note:

The measuring sensor must not sit on the milling cartridge during this step. Tighten the clamping screw for the milling cartridges to 14 Nm using a torque wrench.

Optional:

Tighten the locking screws to approx. 2 Nm using a torque wrench.



10. Using either optical or tactile measurement, identify the milling cartridge with the highest protruding cutting edge and set the dial gauge to zero. Set all milling cartridges in relation to the highest protruding cutting edge using dial gauge: For this purpose, the turn the adjusting screw clockwise using a hex-wrench until the zero dimension is reached (tolerance $\pm 2 \mu\text{m}$).

General information:

- Each time after changing the milling cartridges, the axial run-out and the permissible residual imbalance according to DIN ISO 1940-G2.5 should be checked.
- Ideally the cutting edge measurement should be checked again after balancing.
- The adjusting screw must touch the milling cartridge slightly with generally even clamping to avoid axial movement of the inserts in use.

Setting dimension EM:

Refer to the related product pages for the setting dimensions. The setting dimension EM relates only to the milling cutter's tool body incl. milling cartridges. If a milling cutter with connection is set, the height of the connection l_A must always be taken into account. In this situation the setting dimension is $l_A + EM$.

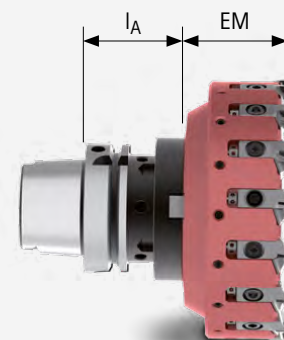

Handling notes for PCD face milling cutters – Eco system

In order to achieve optimal surface finishes in face milling, all cutting edges must run perfectly axially. MAPAL uses a special adjustment system for the face milling head system series (NeoMill-Diamond-Eco, NeoMill-Diamond-EcoBlue, NeoMill-Diamond-RapidBlue and NeoMill-Diamond-FlyCutter). By means of a high-precision wedge adjustment, the axial run-out can be effortlessly set in the required μm range.

The achievable accuracy in combination with the simple handling set this system apart. A MAPAL setting fixture is recommended for straightforward, convenient, quick and precise setting. For example, the UNISET-P with measuring sensor* allows the axial run-out to be set easily and with μm precision in record time.

Changing and setting PCD milling cartridges

Requirements:

The milling cutter is clamped on the setting fixture and the milling cutter clamping screw/coolant screw is tightened (see table "Tightening torque for milling cutter clamping screw/coolant screw" on page 409).

Comment:

- Only for trained personnel
- Clean the cutting edges on the milling cartridges using a cleaning compound to prevent measurement inaccuracies

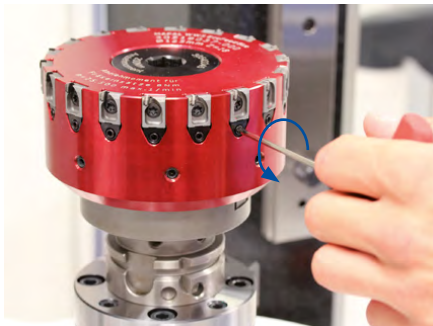

1. Turn the threaded spindle one turn anticlockwise with a hex-wrench, width across flats 2.5.



2. Loosen the clamping screw of the milling cartridge and remove it upwards from the dovetail guide.

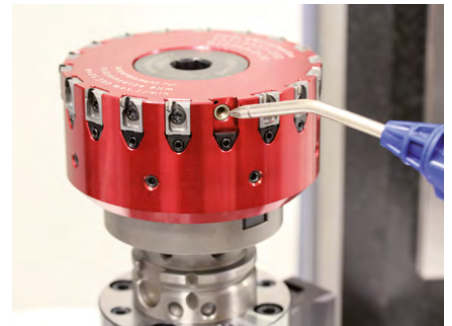

3. Clean the seat of the milling cartridge with compressed air and then insert the new milling cartridge from above into the dovetail guide.



4. Press the milling cartridge lightly while tightening so that the adjusting wedge is in contact. Insert the clamping screw** of the milling cartridge and tighten it clockwise with 1-2 Nm.



5. Use the setting fixture to optically set a milling cartridge -0.01 mm before the setting dimension (EM). To do this, measure the cutting edge with the optical measuring device and turn the threaded spindle clockwise with a hex-wrench until $\text{EM} = -0.01\text{ mm}$ is reached.
For purely optical setting, repeat this process for the remaining milling cartridges (then continue with step 7).



6. Position the dial gauge on the set milling cartridge and set it to zero. Set the milling cartridges with a dial gauge 0.01 mm before EM: To do this, turn the threaded spindle clockwise with a hex-wrench until zero dimension is reached.

* While optical systems reach their limits when it comes to $\mu\text{-}$ accurate adjustment, high-precision adjustments to the axial run-out can be easily realised with the help of the measuring sensor.

** For the use of the clamping screw, please note the information on page 380.

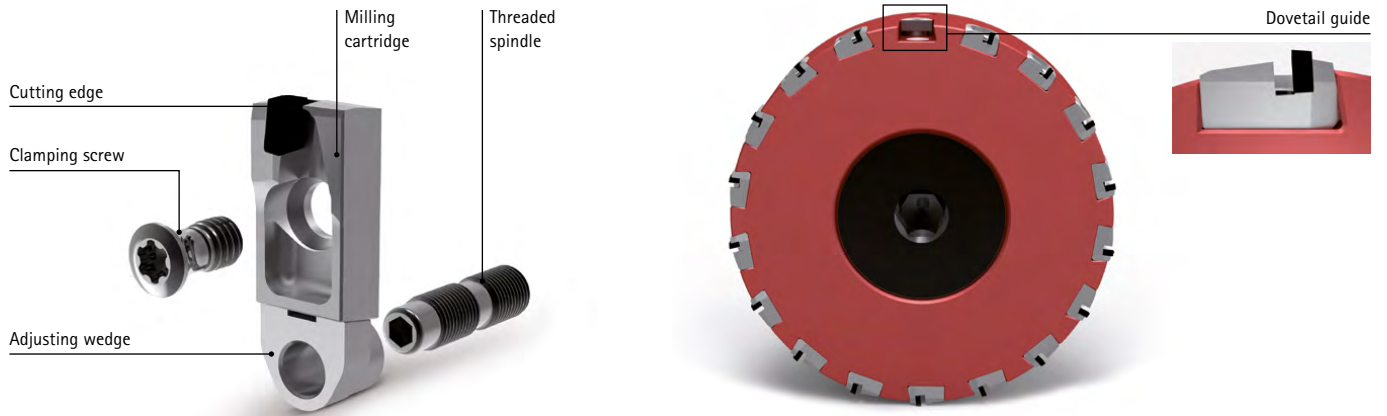

7. Note:

The measuring sensor must not sit on the milling cartridge during this step.

Tighten the clamping screw of the milling cartridge clockwise with a torque wrench (for tightening torques see table "Tightening torque for clamping screws").



8. Using the setting fixture, identify the milling cartridge with the highest protruding cutting edge and set the dial gauge to zero. Set all milling cartridges in relation to the highest protruding cutting edge using the dial gauge: For this purpose turn the threaded spindle clockwise using a hex-wrench until the zero dimension is reached (tolerance $\pm 2 \mu\text{m}$).

Setting dimension (EM):
 Refer to the related product pages for the setting dimensions. The setting dimension EM relates only to the milling cutter's tool body incl. milling cartridges. If a milling cutter with connection is set, the height of the connection l_A must always be taken into account. In this situation the setting dimension is $l_A + EM$.

Tightening torque for clamping screws

Clamping screw Order no.	Dimensions	TORX®-/TORX PLUS® input size	Tightening torque [Nm]
30696524	M5x11	TX25	8
30412229	M4x8,5	15IP	5
30499981	M5x8	TX25	8

Tightening torques for the milling cutter clamping screw / coolant screw

Clamping screw Order no.	Milling head diameter [mm]	Dimensions	Wrench size	Tightening torque [Nm]
30543340	50	M10	SW 8	20
30543341	63	M10	SW 10	50
30543342	80	M12	SW 12	80
30543344	100	M16	SW 14	100
30543345	125	M20	SW 14	200
10006594	160	M12	SW 10	70
10007775	200 - 400	M16	SW 14	70

Handling Instructions for Face Milling Cutters with Radial Indexable Inserts

Applicable to milling cutters with ONKU and OFMT indexable inserts.

Replacing the indexable inserts

Requirements:

The face milling cutter and the indexable inserts have been checked for good condition and cleanliness.

ONKU indexable inserts

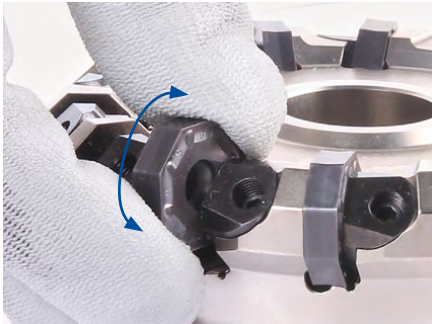

Note:

Before and during the replacement procedure, check the indexable inserts and insert seats for good condition and cleanliness.

1. Loosen the clamping wedge. To do this, use a TORX PLUS® wrench to turn the threaded spindle a few turns anticlockwise.

Note:

When inserting the indexable inserts, pay attention to the numbering of the chip breakers. The numbering should be identical in each insert seat.

2. Insert the indexable insert into the insert seat with repeated slight rocking movements.

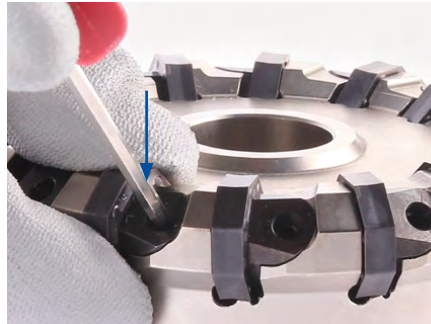

3. Press the indexable insert downwards and make sure that the indexable insert is in contact with the circumference on both contact surfaces.
4. Hold the indexable insert and turn the threaded spindle clockwise with a TORX PLUS® wrench until the clamping wedge is slightly in contact with the indexable insert and fixes it.

Comment:

- Only for trained personnel
- Clean the indexable inserts using cleaning compound

Note:

Before applying the tightening torque to the threaded spindle, all indexable inserts must first be mounted.

5. Tighten the threaded spindle at all clamping wedges to 7.5 Nm using a torque wrench.

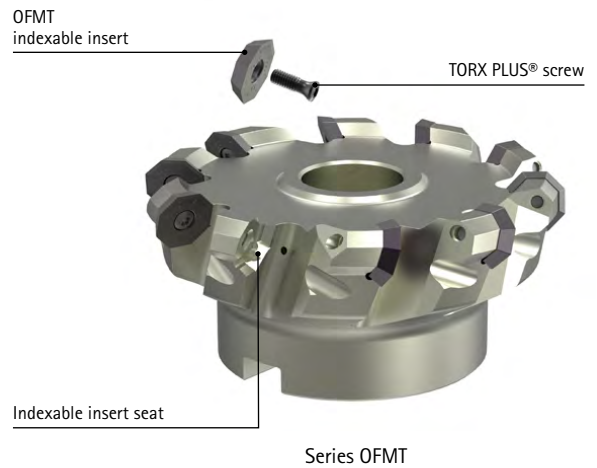
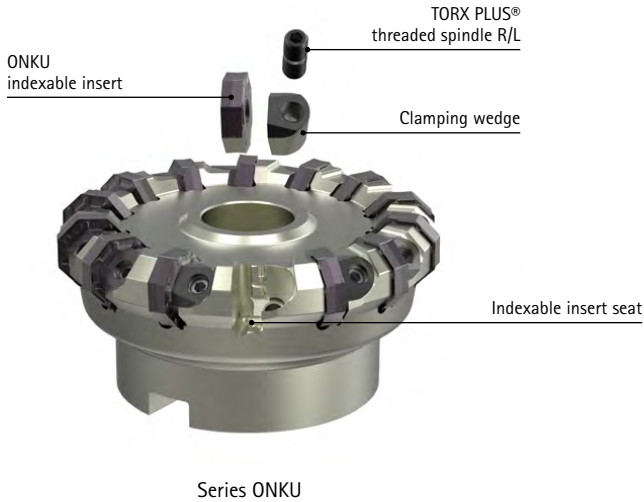

OFMT indexable inserts



Note:

Before and during the replacement procedure, check the indexable inserts and insert seats for good condition and cleanliness.

1. Put the TORX PLUS® screw through the location bore of the indexable insert.

Note:

When inserting the indexable inserts, pay attention to the numbering of the chip breakers. The numbering should be identical in each insert seat.

2. Insert the TORX PLUS® screw together with the indexable insert into the location bore of the indexable insert seat. The indexable insert must not yet be in contact with the insert seat.

3. Using a TORX PLUS® wrench, screw in the TORX PLUS® screw clockwise and simultaneously insert the indexable insert into the insert seat with repeated slight rocking movements.

4. Pull the indexable insert outwards at a 45° angle and simultaneously screw in the TORX PLUS® screw as far as it will go.

5. Make sure that the indexable insert is flat and free of gaps.

6. Tighten the TORX PLUS® screw to 7.5 Nm using a torque wrench.

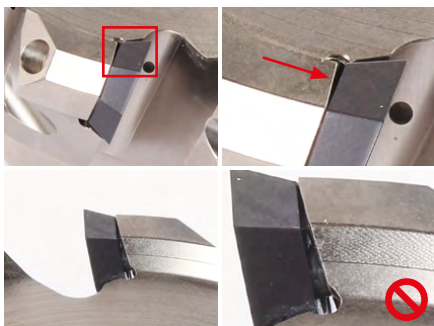

Note:

If the indexable insert is not flat, it must be loosened and remounted.

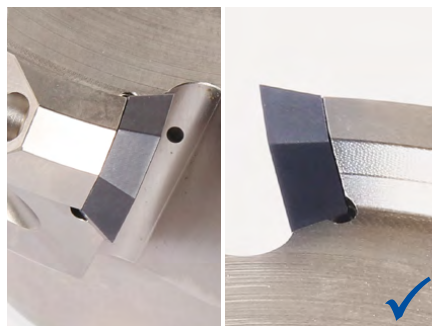

Result:

The indexable insert is correctly mounted and flat.

Handling notes for milling cutter clamping screw

Clamp the tool



1. Remove the driving ring from the milling cutter arbor.



2. Insert the feather key on the milling cutter arbor.



3. Place the first spacer ring on the milling cutter arbor.



4. Place the second spacer ring on the first spacer ring and the milling cutter arbor.

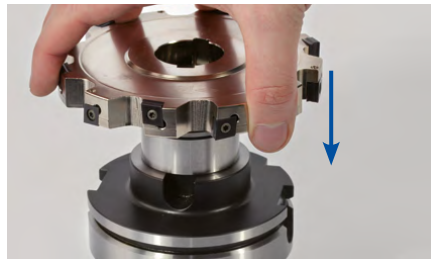

5. Place the tool flat on the milling cutter arbor.

Comment:

For trained personnel only

Note:

The spacer rings are not included in the scope of delivery (see chapter "Accessories and spare parts" on page 383).

Mounting and setting milling cutter clamping screw



6. Turn threaded bolt until it protrudes 1-2 mm in relation to the threaded ring.



7. Slightly screw the milling cutter clamping screw onto the milling cutter arbor clockwise.



8. Screw in the milling cutter clamping screw further clockwise using a hex-wrench and then tighten it with a torque wrench (for tightening torque, see table "Tightening torque for milling cutter clamping screw").

Result:

The milling cutter clamping screw is tightened to the prescribed tightening torque and lies flat against the tool.

Tightening torque for milling cutter clamping screw

Clamping screw Order no.	For milling cutter arbor – ø [mm]	Dimensions	Wrench size	Tightening torque [Nm]
10041356	16	M8	SW 5	28
10009642	22	M10	SW 6	50
10006125	27	M12	SW 8	70
10009686	32	M16	SW 10	95
10006126	40	M20	SW 12	125

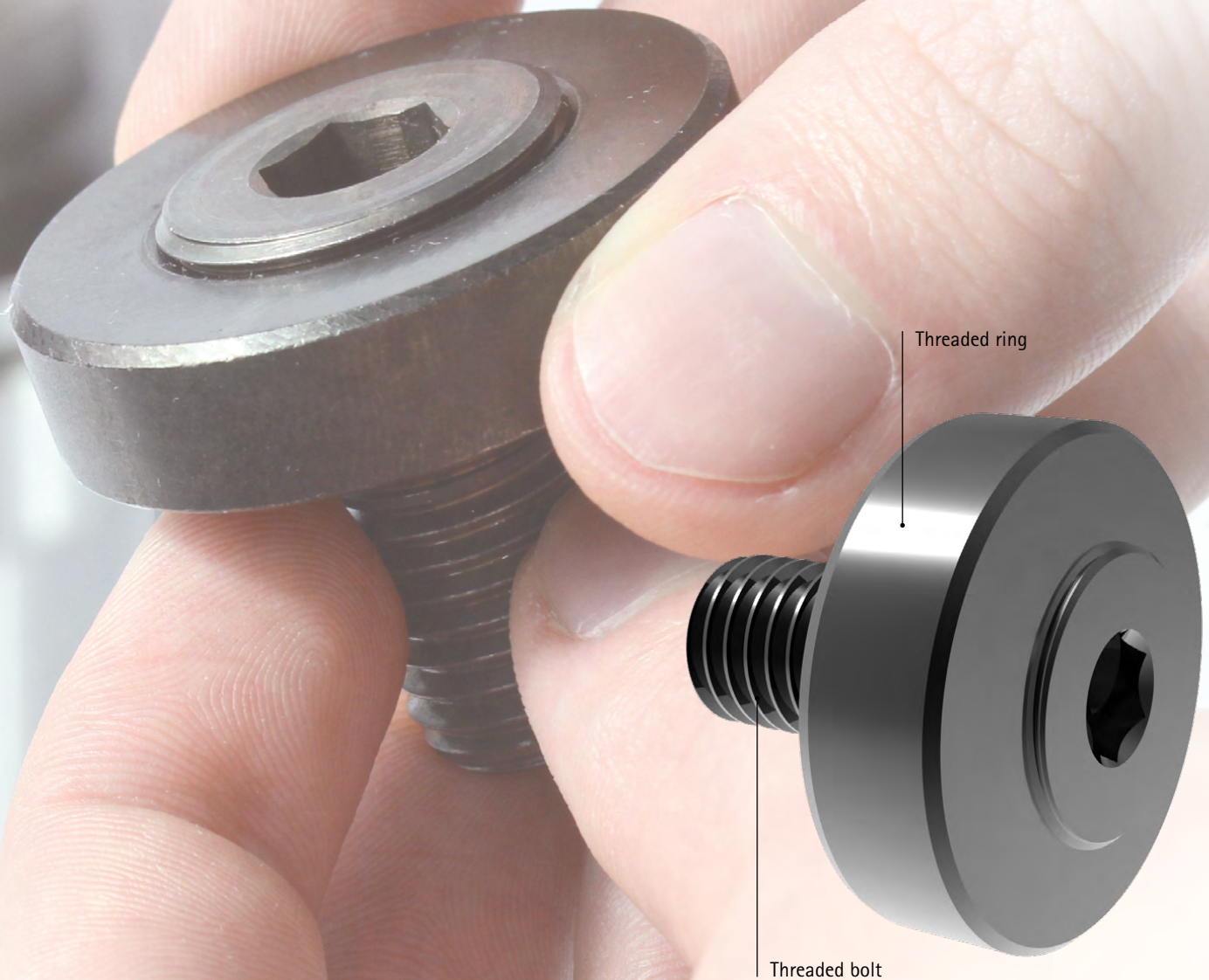

APPLICATION

- Disc milling cutter with milling cutter arbor
- Higher cutting force during machining
- High torques

ADVANTAGES

- Very high clamping force
- Greater safety due to the different pitch on the two threads on the threaded bolt
- Self-locking
- No risk of injury due to slipping wrench
- Higher cost-effectiveness thanks to greater radial and axial run-out accuracy of the milling cutter



MAPAL Maintenance Services

Reconditioning for face milling heads

Significant cost-savings thanks to reliable, quick and precise reconditioning

In machining, customers need to be able to rely on their tools throughout the process, especially after regeneration. Cleanliness, care and precision are the key factors for MAPAL when reconditioning milling heads. With reconditioning to original quality and milling head management, MAPAL offers two recon-

ditioning systems for face milling heads that guarantee precise and reliable tools with full performance. With each reconditioning, the tool life of the tools is significantly increased and costs for new tools saved. The customer receives tools ready for immediate use and can easily reach the familiar tool life. The

tools are collected from and delivered to the customer by courier. The standardised process ensures straightforward, fast processing within a few days.

ADVANTAGES

- Increased tool life
- Reduced tool costs
- Ready-to-use tools in original quality
- On-time collection and delivery
- Increased process reliability
- Reduced capital commitment*

* in conjunction with a milling head management system

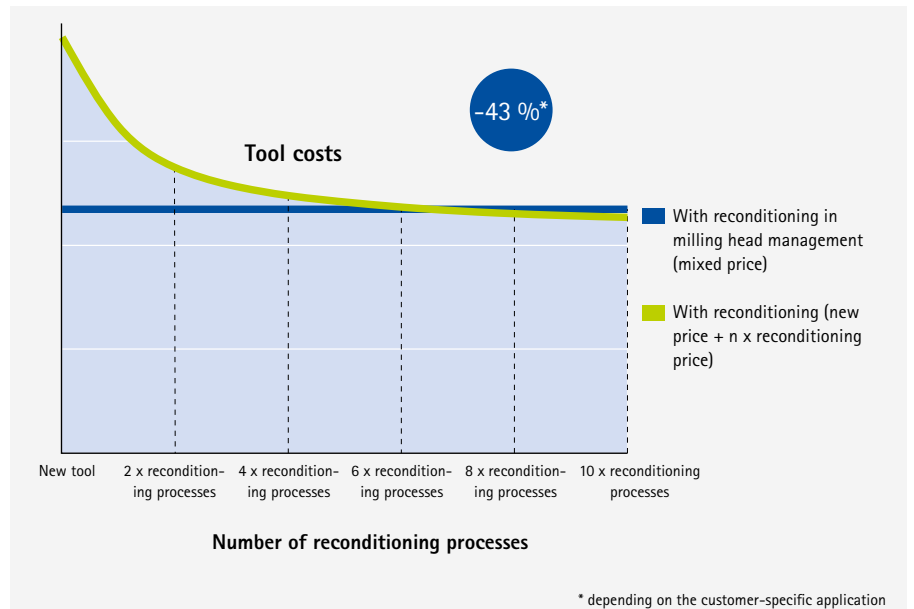



Reconditioning to original manufacturer quality

At MAPAL, the tools are thoroughly cleaned after dismantling, wear and tear parts are replaced, and the system is rebuilt from scratch. Worn milling cartridges go through a repair cycle. The tool is reloaded with stock regenerated cutting edges. After mounting with the corresponding cutter holder, the milling cartridges are set to the original setting dimension (EM). Within five days, the customer gets the tools back ready for use.

Milling head management

In addition to reconditioning to original quality, milling head management includes warehousing. Customers benefit from 24-hour tool availability on site as well as lower capital commitment. Billing takes place at a calculated mixed price upon removal. The customer retains full cost control. Expensive acquisition costs for new tools are eliminated. Bottlenecks due to tool availability are a thing of the past. A customer agreement defines a set process that allows delivery times of a maximum of 48 hours.

Reconditioning cycle

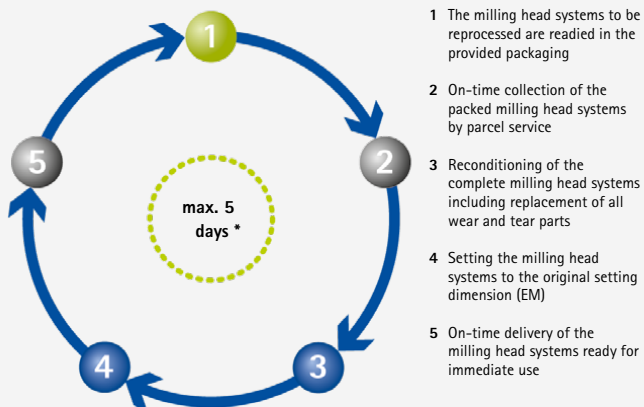

* Valid within Germany. Additional shipping days may have to be taken into account for international shipments

Reconditioning cycle – milling head management

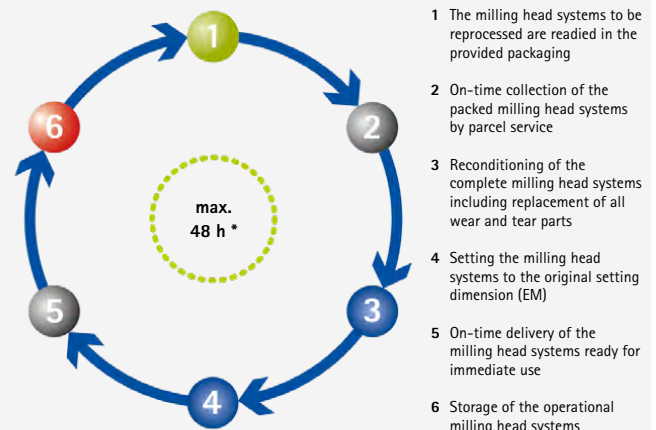

* Valid within Germany. Additional shipping days may have to be taken into account for international shipments

Comment: As a technology partner, MAPAL can help with the selection of the optimal reconditioning process for the individual machining task.

Pictograms

Milling

	Face milling		Shoulder milling		Groove milling		Deep groove milling
	Trimming		Chamfering and deburring		Profile milling		Plunge milling
	Ramps		Helix milling		Trochoidal milling		High-feed milling
	Pocket milling		Tapping		Corner radius		45° chamfer
	Sharp-edged		Process conditions good		Process conditions unfavourable		Roughing
	Medium machining		Finishing		Internal cooling		Shank form HA compatible with DIN 6535
	Shank form HB compatible with DIN 6535		HSK-A connection		CFS/MFS connection		Short
	Long		Overlong		Extra long		Maximum machining depth
	Design DIN 6527						

Configuration

Product with configurable features

Product category

	Basic Line: Universal tools, broad field of application, low procurement costs		Performance Line: High-performance tools, broad field of application, high productivity in series production
	Expert Line: Specialist tools for selected applications, maximum precision and productivity		

Material suitability

Highly suitable
 Suitable in some situations

E.g. Standard material suitability table

P	1	2	3	4	5	6	M	1	2	3	K	1	2	3	N	1	2	3	4	S	1	2	3	4	5	H	1	2	3
	■	■	■	■			■				■	■			■					■									

E.g. Material suitability table for non-ferrous metal and lightweight materials

N	1.1	1.2	1.3	1.4	2.1	2.2	2.3	3.1	4.1	4.2	4.3	G	1.1	1.2	1.3	2.1	3.1	4.1	4.2	5.1	5.2	5.3
										■		■				■			■			

MAPAL machining groups

Machining group		Workpiece material	Strength/hardness [N/mm ²] [HRC]	Frequently machined workpiece materials
P	P1	P1.1 Structural, free-cutting, case hardened and heat-treated steels, non-alloy	< 700 N/mm ²	1.0122 (S235/St 37), 1.0401 (C15), 1.0503 (C45), 1.0570 (S355/St 52), 1.1213 (Cf53)
		P1.2 Structural, free-cutting, case hardened and heat-treated steels, non-alloy	< 1.200 N/mm ²	1.1249 (Cf70)
	P2	P2.1 Nitrided, case hardened and heat-treated steels, alloy	< 900 N/mm ²	1.7131 (16MnCr5)
		P2.2 Nitrided, case hardened and heat-treated steels, alloy	< 1.400 N/mm ²	1.7227 (42CrMo54)
	P3	P3.1 Tool, bearing, spring and high-speed steels*	< 800 N/mm ²	1.2343 (X37CrMoV5-1), 1.2762 (75CrMoNiW6-7)
		P3.2 Tool, bearing, spring and high-speed steels*	< 1.000 N/mm ²	1.2367 (X38CrMoV5-3), 1.2713 (55NiCrMoV6)
		P3.3 Tool, bearing, spring and high-speed steels*	< 1.500 N/mm ²	1.2379 (X153CrMoV12) 1.2738 (40CrMnNiMo8-6-4)
	P4	P4.1 Stainless steels, ferritic and martensitic		1.4510 (X3CrTi17), 1.4589 (X5CrNiMoTi15-2)
	P5	P5.1 Cast steel		1.7231 (G42CrMo4)
	P6	P6.1 Stainless cast steel, ferritic and martensitic		
M	M1	M1.1 Stainless steels, austenitic	< 700 N/mm ²	1.4301 (V2A), 1.4571 (V4A)
		M1.2 Stainless steels, ferritic/austenitic (duplex)	< 1.000 N/mm ²	1.4362 (Alloy 2304), 1.4501, 1.4662 (LDX 2404)
	M2	M2.1 Stainless/heat-resistant cast steel, austenitic	< 700 N/mm ²	
	M3	M3.1 Stainless cast steel, ferritic/austenitic (duplex)	< 1.000 N/mm ²	
K	K1	K1.1 Cast iron with lamellar graphite (grey cast iron), GJL	< 300 N/mm ²	GJL-250 (GG-25), GJL-260 (GG-26 Cr)
		K2.1 Cast iron with spheroidal graphite, GJS	< 500 N/mm ²	GJS-400 (GGG-40), GJS-450 (GGG-45)
	K2	K2.2 Cast iron with spheroidal graphite, GJS	≤ 800 N/mm ²	GJS-600 (GGG-60), GJS-800-2 (GGG-80), GJS-800-8 (ADI 800)
		K2.3 Cast iron with spheroidal graphite, GJS	> 800 N/mm ²	GJS-900-2 (GGG-90), GJS-1000-5 (ADI 1000), GJS-1200-2 (ADI 1200), GJS-1400-1 (ADI 1400)
	K3	K3.1 Cast iron with spheroidal graphite, GJV; malleable cast iron, GJM	< 500 N/mm ²	GJV-300, GJV-400, GJMW-400-5 (GTW-40)
		K3.2 Cast iron with spheroidal graphite, GJV; malleable cast iron, GJM	> 500 N/mm ²	GJV-500, GJV-700
N	N1	N1.1 Aluminium, non-alloy and alloy < 3 % Si		Alloy 2024, Alloy 7075, Al99
		N1.2 Aluminium, alloy ≤ 7 % Si		AlSi7
		N1.3 Aluminium, alloy > 7-12 % Si		AlSi9, AlSi9Cu
		N1.4 Aluminium, alloy > 12 % Si		AlSi12, AlSi17
	N2	N2.1 Copper, non-alloy and low-alloy	< 300 N/mm ²	SE-Cu
		N2.2 Copper, alloy	> 300 N/mm ²	CuSn6
		N2.3 Brass, bronze, gunmetal	< 1.200 N/mm ²	CuZn33, CuAl9Mn3
	N3	N3.1 Graphite, > 8 µm		
		N3.2 Graphite, ≤ 8 µm		
	N4	N4.1 Plastic, thermoplastics		PA, PE, PC, PS, PVC, PP, PTFE, POM, PMMA
		N4.2 Plastic, thermosets		PU, PF, EP, UP, VE, CR
		N4.3 Plastic, foams		EPS, PUR, PVC-E, PS-E, PP-E
C	C1	C1.1 Plastic matrix, aramide fibre-reinforced (AFRP)		Nomex, Kevlar, Twaron, KOREX
		C1.2 Plastic matrix (thermosetting), CFRP/GFRP		IMS, HTA
		C1.3 Plastic matrix (thermoplastic), CFRP/GFRP		GMT-PP, PEEK
	C2	C2.1 Carbon matrix, carbon fibre-reinforced (CFC)		CF222, CF225, CF226, CF227, CF260
	C3	C3.1 Metal matrix (MMC)		CeramTec A0-403 (AlSi9MgMn-Al2O3), Al/Cu/Mg-SiO2/Al2O3/AIN/TiC/SiC/BN/TiB2
	C4	C4.1 Sandwich construction, honeycomb core		
		C4.2 Sandwich construction, foam core		PLASCORE PAMG-XR1 5052, PCGA-XR1 3003, PAMG-XR1 5056, Micro-Cell (core made of alloy 5052/5056)
	C5	C5.1 Composite (stack), non-metal - non-ferrous metal composite		CFK-aluminium, IMS/HTA + Alloy 2024/6061/7075
		C5.2 Composite (stack), non-metal - metal composite		CFK-titanium, IMS/HTA + TiAl6V4/AMS4905
		C5.3 Composite (stack), non-metal - non-metallic composite		CFK-CFK
		C5.4 Composite (stack), non-ferrous metal - non-ferrous metal composite		Aluminium-aluminium
		C5.5 Composite (stack), non-ferrous metal - metal composite		Aluminium-titanium
C5.6 Composite (stack), metal - metal composite			Titanium Inox	
S	S1	S1.1 Titanium, titanium alloys	< 400 N/mm ²	
		S2.1 Titanium, titanium alloys	< 1.200 N/mm ²	TiAl6V4
	S2	S2.2 Titanium, titanium alloys	> 1.200 N/mm ²	
		S3.1 Nickel, non-alloy and alloy	< 900 N/mm ²	1.3912 (Invar, Ni36)
	S3	S3.2 Nickel, non-alloy and alloy	> 900 N/mm ²	
		S4.1 High-temperature super alloy Ni, Co and Fe-based		Hardox, Hastelloy, Incoloy, Inconel, NIMONIC, Stellite, Waspaloy
S5	S5.1 Tungsten and molybdenum alloys			
H	H1	H1.1 Hardened steel / cast steel	< 44 HRC	1.2738 HH, 1.2085, Toolox 33, Toolox 44
		H1.2 Hardened steel / cast steel	< 55 HRC	1.2343, 1.2311, 1.2312, 1.2714, 1.2083, 1.2738
	H2	H2.1 Hardened steel / cast steel	< 60 HRC	1.1730, 1.2379, 1.2358, 1.2767, 1.4112, ASP 2012
		H2.2 Hardened steel / cast steel	< 65 HRC	1.2379, 1.2363, 1.2436, 1.2842, ASP 2005, Vanadis 23
	H2	H2.3 Hardened steel / cast steel	< 68 HRC	ASP 2017, ASP 2023, Vanadis 30, Vanadis 60
		H3.1 Wear-resistant cast/chill casting, GJN		

* If the alloy parts Cr, Mo, Ni, V, W in total > 8 % then select the next highest MAPAL machining group.



Discover tool and service solutions now that give you a lead:

BORE MACHINING

REAMING | FINE BORING

DRILLING FROM SOLID | BORING | COUNTERSINKING

MILLING

CLAMPING

TURNING

ACTUATING

SETTING | MEASURING | DISPENSING

SERVICES

FOLLOW US

